



LIBRARY OF THE
NEW YORK STATE COLLEGE
OF HOME ECONOMICS
CORNELL UNIVERSITY
ITHACA, NEW YORK





Cornell University Library

The original of this book is in
the Cornell University Library.

There are no known copyright restrictions in
the United States on the use of the text.

Cornell University Library
TS 1625.B96

The history of wool and woolcombing,

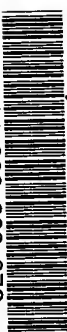

3 1924 003 609 876

main, vol1



Heubmann's Inspiration

THE HISTORY
OF
WOOL AND WOOLCOMBING.

THE HISTORY
OF
WOOL AND WOOLCOMBING

325

BY
JAMES BURNLEY

AUTHOR OF "THE ROMANCE OF INVENTION," "THE ROMANCE OF MODERN
INDUSTRY," ETC.

WITH NUMEROUS ILLUSTRATIONS AND PORTRAITS

LONDON
SAMPSON LOW, MARSTON, SEARLE AND RIVINGTON
LIMITED

ST. DUNSTAN'S HOUSE, FETTER LANE, FLEET STREET, E.C.

1889

Vault
he

TS 1625

B 96

Vault

RICHARD CLAY AND SONS, LIMITED,
LONDON AND BUNGAY.

PREFACE.

OF literature about literature there is an abundance; and books are numerous enough upon most other aspects of human progress; but when we come to survey the vast range of inventive and industrial effort to which our prosperity as a nation is so largely due, we find the records but scant and meagre. To those immediately concerned in the work of industrial development, the various stages of advancement are not lost sight of; but the world at large only appreciates general results; the manifold causes whereby those results have been created are little understood. Still the great work of mechanical and scientific progress is continued from decade to decade, and it is well that occasional attempts should be made to gather into the form of

consecutive narrative the more prominent features of our marvellous industrial growth. Such an effort is represented by the present volume, which aims to trace the growth of the British wool trade and to set forth the origin, and the gradual expansion of the woolcombing machine, from the first germ of the idea to its perfect realization as a contrivance of eminent practicability, which has had a powerful influence upon modern manufacturing enterprises.

The difficulties of the task have not been slight. How large the field of inventive effort is which has had to be explored may be partly gathered from a glance at the long list of woolcombing inventions grouped together in the Appendix. In order to tell the story which remained hidden away, as it were, beneath mountains of blue books in the Patent Office, or which lingered only in the memories of those still living inventors who had taken part in the great woolcombing struggle, much research and much hunting up of personal recollections were necessary; but sufficient has been accomplished, it is hoped, to

render the record not only clear to the general reader, but of interest and value to the trade.

There are certain disadvantages in writing of men that are living. Praise cannot be bestowed upon them without the suspicion of flattery, and mistakes cannot be pointed out without giving offence; but, on the other hand, there is the best means of arriving at an accurate knowledge of facts while the persons are still in existence who are able to vouch for them at first hand. As far as possible I have striven to preserve an independence of observation in pursuing my inquiries, and do not doubt that as time goes on the achievements here chronicled will have their importance still further emphasized.

There are disputed points in connection with one or two phases of the history of woolcombing, important enough as matters of personal honour and veracity, but hardly sufficient to affect the fame or detract from the merit of a particular inventor or invention. The question whether this or that inventor originated a certain mechanical idea is undoubtedly of consequence and of interest, but it is

easy to set too great a value upon such contentions. Watt did not originate the idea of the steam-engine, nor was Stephenson the first to conceive the notion of the locomotive; but these were the men who made the steam-engine and the locomotive practical powers, and to them therefore is due the chief merit of those inventions. In the same way the several woolcombing machines will always be chiefly associated with the names of the men who first worked them into commercial successes.

My acknowledgments are due to several gentlemen for assistance in the getting together of material for my volume. To Mr. Alfred C. Brookes, Fel. Inst. P.A., of the firm of William Brookes and Son, the well-known patent agents, my thanks are especially due for the great service he has rendered me in the compilation of the many technical details which have been necessary to illustrate the leading features of the various woolcombing inventions. I have also to thank Mr. Isaac Holden, M.P., for permission to refer to his private *Retrospective Notes on Woolcombing*, and for the privilege of producing a steel

engraving from the valuable painting in his possession, by A. Elmore, R.A., which forms the frontispiece. I am also deeply sensible of the obligations I am under to Mr. S. C. Lister, for his kindness in affording me information on many points; and to Mr. Jonathan Holden, for giving me particulars of special interest and moment. My gratitude is likewise due to members of the late Mr. G. E. Donisthorpe's family, and to M. Paul Heilmann-Ducommun, for the loan of portraits from which reproductions have been made for the purposes of this volume.

As regards the outline sketch of the history of wool and the wool industries which occupies the earlier portion of the volume, the authorities will be found for the most part acknowledged in the text.

J. B.

CONTENTS.

	PAGE
CHAPTER I.	
THE RAW MATERIAL	I
CHAPTER II.	
WOOL AND ITS USES IN ANCIENT TIMES	34
CHAPTER III.	
THE GROWTH AND VICISSITUDES OF THE WOOL INDUSTRIES	54
CHAPTER IV.	
WOOL AND ITS MANUFACTURING PROCESSES	82
CHAPTER V.	
THE CARTWRIGHT ERA	105
CHAPTER VI.	
THE TRANSITION PERIOD	142
CHAPTER VII.	
THE DECLINE AND EXTINCTION OF THE HANDCOMBER	159

	PAGE
CHAPTER VIII.	
THE BISHOP BLAIZE COMMEMORATIONS	186
CHAPTER IX.	
JOSUÉ HEILMANN	211
CHAPTER X.	
S. CUNLIFFE LISTER	242
CHAPTER XI.	
ISAAC HOLDEN	278
CHAPTER XII.	
THE INTRODUCTION OF THE SQUARE MOTION PRINCIPLE	298
CHAPTER XIII.	
FURTHER DEVELOPMENTS OF THE SQUARE MOTION	324
CHAPTER XIV.	
THE NOBLE MACHINE	373
CHAPTER XV.	
SUMMARIES, COMPARISONS, AND CONCLUSIONS	396
APPENDIX	421
INDEX	477

LIST OF ILLUSTRATIONS.

STEEL PLATES AND PHOTOGRAVURES.

	PAGE
Heilmann's Inspiration <i>Front.</i>	
Dr. Edmund Cartwright	112
Handcombers at Work	176
Josué Heilmann	216
S. Cunliffe Lister	248
G. E. Donisthorpe	274
Isaac Holden, M.P.	292
General View of the Square Motion Woolcombing Machine . . .	308

DIAGRAMS.

FIG.		
1.	A Pair of Combs	89
2.	Post for fixing Combs	89
3.	Dr. Cartwright's "Big Ben"	117
4.	Bird's-eye View of Dr. Cartwright's Machine	122
5.	Dr. Cartwright's "Big Ben"	125

FIG.	PAGE
6. Bird's-eye View of Collier's Machine	147
7. Elevation of the Side	148
8. Elevation of the Side	149
9. Elevation of the Side	150
10. The Combing Roller	150
11. The Combs	152
11. Enlarged Diagram of the Combs	152
12. Side Elevation of the Platt-Collier Machine	153
12. Enlarged Drawing of the Platt-Collier Machine	153
13. Heilmann's Machine—End Elevation	223
14. Ditto. Vertical Section	225
15. Ditto. End Elevation	227
16. Ditto. A Vertical Section of the Working Details	229
17.—22. Ditto. The most Important Working Parts in detail.	230
23. Section of Lister and Donisthorpe's "Nip" Machine	255
24. General View of the Later Form of Lister's "Nip" Machine	263
25. Sectional View, Showing One Drawing Off and Two Feed Heads	264
26. Another Sectional View of Lister's "Nip" Machine	267
27. The Carrying Comb	269
28. Another View of the Carrying Comb	270
29.—32. Various Kinds of Carrying Combs and Fallers	272
33. Washing Trough	304
34. Feed Rollers	304
35. End View of Combs	305
36. Details	305

FIG.	PAGE
37. Details	305
38. Section of Portion of Machine of May 5th, 1856	315
39. Portion of Front View of Machine of May 5th, 1856	316
40. Square Motion Comb Bars prior to Improvement of May 5th, 1856	318
41, 42. Improved Form of Bars	318
43, 44. Sectional View of Working Parts of Machine of January 30th, 1857	326
45. Plan of Working Parts of Machine of January 30th, 1857	327
46. Detached View of Circles	328
47. Plan View of Segments of Combs	329
48. Section of Segments of Combs	331
49. Stationary Frame	332
50. Section of Apparatus	335
51. End View	337
52. Plan of Segmental Combs	338
53. Section of Segmental Combs	340
54. Feed Rollers	341
55. View of Motion	343
56. Sectional View of Motion	345
57. Improvements of June 27th, 1862	348
58. Improvements of June 27th, 1862	350
59. Screw Action	351
60. Screw Action	352
61. Section of Conductors to "Nacteur" Combs	353
62. Front View of Conductors	354

FIG.	PAGE
63. Plan View of Drawing-off Apparatus	360
64. Sectional View of Drawing-off Apparatus	361
65. End View of Rubber	362
66. Motion to Circle of Comb Teeth	364
67. Sectional View of Same	365
68. View of Guard Plate	367
69. Plan of Noble Comb Rings	381
70. Transverse Section of Noble Apparatus	382
71. General View of the Noble Woolcombing Machine	385
72. Whitehead's Noil Conductors	391
73. Lister's Self-lubricating Dabbing Motion	393

THE HISTORY
OF
WOOL AND WOOLCOMBING.

CHAPTER I.

THE RAW MATERIAL.

WOOL occupies the first place in the history of textile manufactures, both as regards antiquity and importance. As far as our own country is concerned it seems to have been the foundation upon which our commercial fabric has been built, and in all the records of history dealing with the industries of the earliest civilisations, we find this delicate fibre holding a prominent position. The properties which would commend it to the ancient nations would be its ready adaptability as a protective covering, and the great variety of treatment of which it was capable, as well for the purposes of adornment as of utility. Before entering upon the broader subject of the history

of the raw material, however, it will be well that we should make some attempt to define what wool is.

From the prosaic, every-day standpoint this would seem to be an exceedingly simple matter, but science, which dives into the nature of things, does not find the task quite so easy. First of all, then, it is necessary to say that although, in its common commercial significance, the term wool has a very wide application—comprising the hair of the alpaca, goat, beaver, rabbit, and other animals, in addition to the fleece of the sheep—still it is only in its latter form that it is strictly entitled to be styled wool. Dr. Johnson was correct therefore when he described wool as “the fleece of the sheep”; but a later lexicographer was hardly so accurate when he supplemented this with the information that it is “any short, thick hair.” The technical mind demands a more analytical definition, and this Professor Owen endeavoured to give when he alluded to wool as “a peculiar modification of hair characterised by fine transverse or oblique lines, from 2,000 to 4,000 in the extent of an inch, indicative of a minutely imbricated scaly surface when viewed under the microscope, on which, and on its curved or twisted form, depends its remarkable felting property.” Another instructed authority—Youatt—alludes to it as consisting of “a

central stem or stalk, probably hollow, or at least porous, and possessing a semi-transparency not found in the fibre of hair. From this central stalk there springs at different distances in different breeds of sheep a circle or leaf-shaped projection. In the finer species of wool these circles seemed at first to be composed of one imbricated or serrated ring; but when the eye was accustomed to them, this ring was resolvable into leaves or scales. In the larger kinds the ring was at once resolvable into these scales or leaves, varying in number, shape, and size, and projecting at different angles from the stalk, and in the direction of the leaves of vegetables, *i.e.* from the root to the point. They give to the wool the power of felting."

Generally speaking, the lines of demarcation between wool and hair are distinctly defined, but between some varieties of wool and some kinds of hair there is a kinship which almost seems to put them on the same industrial plane. Mr. Walter S. B. McLaren, M.P., with much practical knowledge of the subject, draws the distinction between hair and wool as follows: "A hair has a smooth surface, comparatively free from jagged edges or serratures of any size, and lies straight; while the fibre of wool is more or less waved, and is covered with serratures. A fibre of wool may in fact be likened to a serpent's

skin, or to a fir-cone covered with scales. The serratures, or saw-like teeth, representing these scales, overlap each other and present innumerable little points, which act as hooks. They are extremely small, and in the fibre there are said to be from 1,200 to 3,000 per inch. When wool is spun, these serratures to some extent fit into or catch each other, and help to bind and lock the fibre together; consequently, other things—such as length, quality, &c.—being equal, wool which has many serratures will spin better than wool which has few.”

The inquiries into the nature and composition of wool have been both numerous and complete of late years, but perhaps no scientist has made more elaborate investigations on the subject than Dr. Bowman, of Halifax, who describes wool as “living appendages of the skin, produced by the involution and subsequent evolution of the epidermis; the involution constituting the follicle or *sac* in which the hair is enclosed, and the evolution, the shaft of the hair.” He also observes that “the size of the fibre is very irregular, scarcely any two from the same staple being found alike, and each varying in its length.” The curl of the wool is another notable characteristic of the commodity; and on this point Mr. T. Burgess has good claim to be heard. He says, “As soon as the point of the fibre has protruded through the skin of the animal, a series

of growths takes place, a small part of the epidermis is converted into wool, and then a rest ensues. One side grows faster than another, and hence probably the curly form of the fibre. When another growth takes place, another ring is added, the new growth pushing up the hair from below." On this point Dr. Bowman remarks, "The finer the wool the greater the tendency to curl, for when the diameter of the fibre is $\frac{1}{840}$ of an inch, the number of curves is more than double of that which pertains to the fibre whose diameter is $\frac{1}{510}$ of an inch." The diameter of the fibre in decimals of an inch varies in merino from $\cdot 0177$ to $\cdot 0059$. From a South-down fleece one fibre that was examined was stated to be $\frac{1}{389}$ of an inch, while another near it was $\frac{1}{1749}$. An analysis of the composition of wool yielded the following:—Out of 100 parts, carbon was 50·65; hydrogen, 7·03; nitrogen, 17·71; oxygen and sulphur, 24·61; while 98 per cent. would be organic, two per cent. would be ash. This ash consisted of oxide of iron, sulphate of lime, phosphate of lime, and magnesia. Treating of the yolk or oily secretion from the skin of the sheep, Vanquelin says, "The greater part of it is a soap with a base of potash." And in this connection it should be added that English sheep possess this quality in a much less degree than those of warmer climates. The merino excels all others in this respect.

This fatty secretion materially affects the character of the wool, acting not only as a preservative, but imparting softness and pliability to the fibre. Still, although the yolk is such a valuable aid to the production of sound wool, and is so necessary to the warmth and comfort of the sheep, it must be removed before the wool can be submitted to the processes of manufacture. The extraction is effected by washing. This is generally done, in the first instance, by the farmer, who washes or half-washes the fleece before shearing; in many cases, in Australia and elsewhere, however, the fleeces are sent to the market unwashed, the result being that the entire yolk falls to the manufacturer, who recovers and disposes of the potash from the washings. After full solution the yield is generally, says Dr. Bowman, 140 to 180 lbs. of dry sudorate of potassium, or from 70 to 90 lbs. of pure carbonate, and 5 to 6 lbs. of sulphate and chloride of potassium from every 1,000 lbs. of raw wool. A composition called *Cholesterin*, and other substances of more or less value are also obtained from the yolk of the sheep.

At this point it will be advisable to make a brief reference to the various breeds of sheep and qualities of wool, and to indicate how these have been successively developed as the progress of the woollen and worsted manufactures has demanded. Not only is wool classified according to the countries which produce

it, but it varies considerably in quality and value in the same fleece. The first fleece taken from the animal is of course the lamb's wool; all subsequent crops are ordinary fleeces, taken generally once, sometimes twice a year, in the latter case furnishing winter and summer wool. A fleece fresh from the hands of the shearer will weigh from 6 lbs. to 12 lbs., but after being cleansed of its impurities in the mill will not weigh more than from 2 lbs. to 4 lbs. Some English wools, however, weigh considerably more. The best part of the fleece—the closest, longest, softest, and most even—grows on the shoulders and sides; the yield of the neck is a trifle inferior; and on the loin and back there is a perceptible falling off in fineness and length. On the upper part of the legs the staple begins to hang considerably, and the wool of the upper part of the neck is of worse quality and inclined to be faulty. At the root of the tail the fibre is coarser and more glossy; and at the lower part of the leg the grease in the wool imparts a darker shade and the staple shows a disposition to twist. In the throat the fineness, softness, and curliness reach the vanishing point, and patches of false hair occur; the wool on the head is short, coarse, harsh and extremely glossy; that on the lower part of the throat and chest is of the same quality as that on the throat itself, though shorter through the friction against bars and fences,

while the portion of fleece growing on the shin is short, glossy, coarse, and dirty.

Coming now to the question of the breeds of sheep, we find ourselves confronted by a mass of evidence which almost defies dissection. No naturalist has yet succeeded in tracing the links of evolution that reveal the direct descent of the domesticated animal from the wild species, although that such a kinship existed is as likely as that the savage was the antecedent of civilized man. On the subject of the antiquity of the sheep, Professor Owen is of opinion that this animal is not geologically "more ancient than man, and that it is not a native of Europe that has been introduced by the tribes who carried hither the germs of civilization in their migrations westward from Asia." The negative testimony of geology on this point is that "no unequivocal remains of the sheep have been found in the bone caves, the drift, or the more tranquil stratified, newer pleiocene deposits, so associated with the fossil bones of oxen, wild boar, wolves, foxes, otters, beavers, &c., as to indicate the coevality of the sheep with those species, or in such an altered state as to indicate them to have been of equal antiquity." But while this evidence carries weight as far as it goes, it by no means precludes the assumption that the wild kinds of sheep, yielding mostly hair in their native condition, have, under domestication, been gradually transformed into

producers of pure wool. It has been repeatedly shown that when the Argali (the wild sheep of the Monguls) is removed from its original haunt the hair on its body diminishes in quantity and its growth of wool increases; and, on the other hand, when domesticated sheep are left to roam the moors and uplands without restraint, they display a decided tendency to the formation of hair amongst the wool. All this may not amount to absolute and positive proof that our sheep are derived from any known wild species, nevertheless it is much more than mere conjecture.

Faced with this initial difficulty, it is not to be wondered at that there should be some perplexity in the matter of the classification of sheep. According to some naturalists, there are only three distinct breeds,—(1) The *Ovis Ammon*, or Argali, the wild sheep of Asia and America; (2) the *Ovis musmon*, or *moufflon*, found in Southern Europe and Northern Africa; (3) the *Ovis aries*, or domestic sheep, which abound in Europe and notably in England. Others again contend that there are only two really distinct varieties of sheep—the long-woolled and the short-woolled, and that all others are but varieties of these two, obtained by crossing and influences of climate and pasturage.

It is necessary, however, in giving a survey of the numerous breeds of sheep, to note the various divisions

and sub-divisions of these animals now existing, without troubling ourselves too particularly to ascertain by what processes of selection or action of nature these results have been brought about. For our own purposes we cannot do better than follow the classification adopted by Professor Archer, who having studied the subject from an industrial point of view, naturally inclines to the exposition of such distinctions as can be appreciated in the manipulation of wool by machinery. He groups those sheep which are domesticated or useful to man under four separate geographical heads, as belonging to (1) Europe, (2) Asia, (3) Africa, (4) America. In these groups he enumerates thirty-two varieties, four of which he apportions to Europe, fifteen to Asia, eleven to Africa, and two to America, in the following order:—

I. EUROPE—

The Spanish or Merino sheep.

The common sheep.

The Cretan sheep.

The Crimean sheep.

II. ASIA—

Hooniah, or black-faced sheep of Tibet.

Cago, or tame sheep of Cabul.

Nepaul sheep.

II. ASIA—*continued.*

- Curumbar or Mysore sheep.
- Gārār or Indian sheep.
- Dukhan or Deccan sheep.
- Morvant de la Chine or Chinese sheep.
- Shaymbluir or Mysore sheep.
- Broad-tailed sheep.
- Many-horned sheep.
- The Pucha or Hindostan Dumba sheep.
- The Tartary sheep.
- The Javanese sheep.
- The Barwell sheep.
- Short-tailed sheep of Northern Russia.

III. AFRICA—

- Smooth-haired sheep.
- African sheep.
- Guinea sheep.
- Zeylan sheep.
- Fezzan sheep.
- Congo sheep.
- Angola sheep.
- Yenu or goitered sheep.
- Madagascar sheep.
- Bearded sheep of West Africa.
- Morocco sheep.

IV. AMERICA—

West Indian sheep found in Jamaica.

Brazilian sheep.

But even this classification, numerous and far-reaching as it is, cannot be said to be exhaustive. Indeed, if we come to the investigation of sub-varieties, we are met with the authoritative assertion that the common sheep alone has no fewer than thirty-one of these sub-distinctions; and even with this extensive classification the diversities are by no means exhausted. We need not stop to consider the breeds of wild sheep, further than to give the names and mention the geographical position of existing varieties. The Argali is a native of the Asiatic wilds; the wild sheep of America are mostly located in the regions of the Rocky Mountains; while the *Musmon* abounds both in Africa and Europe, being numerous in the islands of the Greek Archipelago, and extending its range through Corsica and Sardinia into the mountains of Murcia in Spain. Our concern, however, is with the domestic animal, the wool-yielding creature to whom we are indebted for such a large portion of our clothing. The United Kingdom, while unfavourable to the growth of the best wools, still gives us a great variety of sheep; and here again we have strongly-marked geographical distinctions, the wool and flesh of mountain sheep differing considera-

bly from the wool and flesh of the sheep of the grass lands or plains. Dr. Bowman divides British sheep into four separate groups. First, the wilder and most primitive breeds, embracing those of the extreme north of Scotland, the Orkney and Shetland islands, and the Hebrides, which are more like goats than sheep in appearance and habits, and yield a short, coarse wool; and also including the mountain sheep of Wales and Ireland. Second, the forest and mountain breeds, comprising the Exmoor and Dartmoor sheep, the black-faced heath or moor sheep of the higher ranges of Derbyshire, Lancashire, Yorkshire, Cumberland, and Westmoreland, and the Cheviot of Northumberland and the south of Scotland, the Lonk, a cross with the black-faced sheep, being considered the best adapted for the hilly districts. Third, the ancient upland breeds, which have as distinctive classes the Norfolk, Dorset, Portland, Old Wiltshire, Old Hampshire, Hampshire Downs, Southdown or Sussex, Shropshire speckle-faced, and the Ryeland, and all yield fine short-woolled fleeces. Fourth, the long-woolled breeds, of which we shall give a fuller description, since it is with the fibre that they produce that we are chiefly concerned in relation to the history of wool-combing.

Long-woolled sheep are much larger in build than the short-woolled races, and grow a great length and

weight of fleece, some of our native breeds being superior to those of any other country. The West and Midland counties are their original localities, but in recent years farmers have not found it difficult, with improved methods of agriculture, to establish them in other parts of the country. In the British long-woolled category we find the Lincoln, Romney Marsh, Teeswater, Warwickshire, Bampton Nott, Devonshire Southam, Cotswold, New Oxford, and the Leicester varieties.

The Lincoln has been long established in the fen country. Ellis wrote of it as the "longest-legged and largest-carcased sheep of any ; and although their legs and bellies were for the most part devoid of it, they carried more wool on them than any sheep whatsoever." Another writer has described it as "a living square of wool." Its characteristic features are high, bony legs, small face, coarse carcass, deep belly, hollow back, forward shoulders, thick neck, deep dewlap, fat rump, and good hind quarters, and yields as much as 14 lbs. of wool. A considerable improvement in breed has been effected by crossing the Lincoln with the Leicester. The Romney Marsh is a hardy sheep, very valuable for cross-breeding. It withstands the inclemencies of the English climate well, and produces a long, fine wool. Its distinguishing points are a thick, broad head, long neck, wide back, deep belly, narrow

chest, and flat sides. The Teeswater is a very heavy sheep, and has been subjected to so much crossing that pure specimens are not now common. It is powerful of build and slow of growth, and bears a coarse wool, the fleece being open and thin on the back. The Cotswold is a highly domesticated animal, giving a long and somewhat coarse wool, mellow to the touch. It is noted for its considerable size and is without horns. It has slender legs, deep flank, straight back, small ears, tufted forehead, full hind-quarters, thick feet, and shows a tendency to fat on the back. The largest, and in many respects the most important, of British long-woolled sheep is the Leicester, which has undergone many transformations in the course of the last two centuries, what is called the New Leicester being the largest of the long-woolled class, having a rapid growth and being easily fattened. A grazier named Bakewell is credited with the development of the new from the old Leicester, his successful efforts dating from 1760. "Taking the native sheep," says one authority, "he reduced his size, gave him small offals, induced him to lay on flesh and fat all along the breast, sides, shoulders, flank, and neck. He opened his wool, and also reduced it in weight and a little in length." Not only did he effect an improvement in his own flock, but he extended his useful work so much that almost a new race of sheep was the result.

Exceedingly profitable, too, were his experiments. He did not sell his rams, but let them out, making in one year—1789—no less a sum than 3,000 guineas by the use of ten rams; indeed, it is recorded that in 1786 he received a hundred guineas for one service of his best ram. Dr. Macdonald's description of a true Leicester is regarded by experts as perhaps the fullest that has been given. He says, "The head is long, small, projecting forwards horizontally and tapering towards the muzzle. It is hornless, with eyes prominent and placid; ears long, thin, and directed backwards. The base of the neck is full and broad, the junction with the head fine; the line of the neck, tapering between those points, should continue straight to the shoulder, so as to nearly produce one continuous horizontal line from the rump to the poll. The breast is broad and full; the shoulders round and without regular formations either at the junction of the back or neck, particularly with no rising of the withers or hollow behind the bones. The arm is fleshy throughout down to the knee. The legs stand wide apart, are small of bone, and comparatively bare of wool. The chest and barrel are deep and round, the ribs forming a considerable arch from the spine, so as in some cases, and especially when the animal is in good condition, to make the apparent width of the chest even greater than the depth. The barrel is ribbed well home, with no

irregularity of line on the back or belly ; but on the sides the carcase diminishes in width very gradually towards the rump. The quarters are long and full, and, as with the forelegs, the muscles extend down to the hock ; the thighs also are wide and full. The legs are of moderate length. The pelt is moderately thin, but soft and elastic, and covered with a good quantity of white wool."

But great as the diversity is as regards the sheep of the United Kingdom, it is still more remarkable in foreign sheep, all the four quarters of the globe producing many distinct varieties, ranging from the famous Spanish merino to the African Adimain. At the head of the list of wool-bearing animals stands the Spanish merino, which has been acclimatised in several countries, and is more or less represented in all the leading breeds of sheep throughout the world. The favourite breeds are the Escorial, the Guadeloupe, the Paular, the Infantando, the Montareo, and the Nigretti. It is the migratory merino, the Transhumantes, as it is called in its native country, that is the most celebrated of the species. There is a tradition extant that the original merino sheep belonged to England and that specimens were taken over to Spain early in the fifteenth century, yet the story carries very little weight when it is remembered that long anterior to that period—even before the

Roman occupation of that country—Spain had a great reputation for its fine wool. So when we read that John of Gaunt, in 1399, sent over a number of sheep to Spain as part of the dowry of his daughter, we may regard the incident rather as an interchange of courtesy than as supplying Spain with a kind of sheep that the country had not previously possessed. Some philologists, with more ingenuity than wisdom perhaps, have endeavoured to trace the word *marino*, or ultra-marine, from the tradition referred to, as indicating that the sheep had been brought from over the sea. If the merino had been a native of England, it is improbable that during the many centuries of protective legislation in support of the British wool industries, such a valuable wool-producing animal would have been allowed to die out. At all events, the merino sheep was not classed among the English breeds in the middle of the last century. Lasteyrie was of opinion that the merino came from Barbary, but he did not adduce conclusive evidence in support of that theory. It is undisputed that Spain has for many centuries produced the finest sheep and the finest wool; and although in recent times it has lost its pre-eminence as a wool-growing country, it is only because of the effective transplanting of its own sheep to other lands that this decadence has been brought about. Not the least remarkable feature of

this dispersion of the Spanish flocks is the fact that the merino has everywhere maintained its characteristics, no amount of inter-breeding destroying the original qualities of the sheep where the climatic influences have been favourable. The migratory sheep of Spain is distinguished from the British by bearing wool on its forehead and cheeks; its horns are large, ponderous, and convoluted laterally; and its wool is long, soft, and twisted into silky spiral ringlets, and is of very fine quality. In no other country are flocks of sheep subjected to such regular migrations as the merino of Spain. They are led twice a year—in April and October—a journey of four hundred miles, passing the summer season on the slopes of the Pyrenean mountains, and the winter on the plains towards the south. They travel in detachments of 10,000 each, guarded by fifty shepherds and as many dogs, with a mayoral or chief shepherd at their head, and possess a general right of pasturage over the whole of the kingdom. The chief shepherd, together with several specially trained and tamed sheep, heads the flock, and the rest follow in admirable order, the under-shepherds and the dogs gathering round the fringes of the procession, and keeping the stragglers from falling too far into the rear. At times they travel from eighteen to twenty miles a day, though where the pasturage is particularly good they

make frequent halts. The farmers and landed proprietors often suffer considerably from the compulsory accommodation which they are obliged to afford to these wandering flocks, but the right is one that has been possessed from time immemorial, and cannot be interfered with, there being no less than 10,000,000 sheep of the migratory class in the country, representing no small portion of the national wealth. The migratory instinct is strongly manifested in the animals; in April they begin to be restless, and if not closely watched will set forth themselves towards the distant hills, many of them escaping in spite of the utmost vigilance of the shepherds, in which case the fugitives betake themselves to the cooler pasture-grounds and there await the arrival of their companions, unless they have the misfortune in the meantime to fall a prey to the wolves which frequent the mountainous districts of the Pyrenees.

It was largely due to the interest which George III. took in the Spanish merino that this splendid breed was first imported into this country. At the time many of those most concerned were of opinion that it "would neither acclimatise nor cross." But, as has been so often shown, science saw further even than the practical experts. Sir Joseph Banks interested himself greatly in the subject and expressed his belief that merino sheep in time might be produced "with

carcases perfectly fashionable and wool as perfectly fine." Lord Western too was an active agent in developing the breed in England. In an interesting communication made by him in 1842, having reference to his own efforts in this direction, he says: "My first flock had its origin in the gift from His Majesty George III. of forty ewes, accompanied by a request, through Sir Joseph Banks, that I would fairly try how far it was possible to make them into *mutton* sheep. He said that many years' experience in Windsor Park had proved distinctly that the English climate would not deteriorate the wool, and the object then was to see if the carcase could not be so improved as to make them a valuable article on the butchers' shambles. I was rather unwilling to undertake the work, having a very good flock of Southdowns at the time, and the appearance of these Spaniards being most unpromising. I did, however, undertake it, and gave a pledge to His Majesty, through Sir Joseph Banks, that I would do my utmost to succeed in the attempt. Five hundred had been sent by the Cortes to our King to be distributed amongst his subjects, and they were then at Portsmouth. As soon as I got the order I sent there immediately and selected my ewes out of the five hundred. I gave them immediately the fullest attention and redeemed the pledge to His Majesty. In a short time I parted

with the whole of my Southdown sheep. I have certainly enlarged and improved the carcase beyond my early hopes, and, indeed, to the surprise of my brother farmers in general." At first sight, it would appear that George III., Sir Joseph Banks, and Lord Western concerned themselves more with the improvement of the quality of butchers' meat than the bettering of the quality of wool, but that the latter object was not lost sight of is evident from the statement, which was appended to the communication of Lord Western already alluded to, to the effect that in regard to wool he had directed his "views to the growth of a fine combing wool, and having at present little demand for the stock among English farmers, had sought a foreign market with success." He added, "I breed rams for the Colonies, and have a sale for all I can breed of sufficient quality for this purpose."

There was a Merino Society formed in 1811, of which Sir Joseph Banks was president, and great efforts were made to establish the breed of Spanish sheep in England; but many circumstances—amongst others, the reduction of the foreign wool duty—made it of such little profit to cultivate it in preference to the native products, that it was a relief to all parties when an opening was found in the Australian Colonies for the successful acclimatisation of this sheep.

Australia had no native sheep whatever, and when the first attempts were made to introduce the animal from other countries, the State, which had reserved this region as a convict settlement, looked with no particular favour upon the gathering of flocks and herds there. A few adventurous spirits had migrated thither from England and embarked in pastoral pursuits, and had prospered fairly well, but the shadow of the penal institution sat heavily upon them and restricted their efforts. The first breeds of sheep introduced in Australia were the Cape and Bengal species ; and these were the only sheep settled in the Colony before the memorable advent of the Spanish merino. A few sheep of this species were taken over from the Cape of Good Hope to Sydney, Captain Waterhouse and Captain Macarthur being the pioneers in the good work, the former as the first importer of the animal into New South Wales in 1794, the latter as the prime agent in the great movement of establishing the growth of fine wools in that country. Captain Macarthur was so firmly convinced of the suitability of the Colony to this pastoral industry that he made a special visit to England in 1803 to urge the Government to give encouragement to his various schemes, one of which was to obtain a grant of land for himself for the pasturage of his flocks, and another to promote a Pastoral Company of British capitalists for the

development of wool-growing in the Colony. The success which attended his enterprise is a matter of familiar history. In 1794 there were only 526 sheep in New South Wales; in 1796 the number was 1,531; in 1801 it had risen to 6,757; and in 1803 to 10,157. From that time the increase was rapid, the number standing at 7,396,895 in 1851; at 16,278,697 in 1871; and at 46,963,152 in April 1888. In the whole of the Australian Colonies at the last-named period there was a total of 96,462,038 sheep. The exports of wool from all the Australian colonies in 1887-8 are put down at 1,283,350 bales.

It was not until 1834 that sheep were introduced into Victoria. The long-wool breeds yield the best results in that Colony. The first official return of Victorian sheep was in 1836, when there were 41,332; by 1846 the number had been augmented to nearly three millions; and the progress was very marked up to 1879, at which time the highest record was reached with 11,749,532 sheep; there having since been a decrease, the return being now about a million less. South Australia was for a long time considered unfavourable to the keeping of flocks, but shortly after their establishment in Victoria the experiment was tried in the former Colony with fairly satisfactory results, there being 28,000 sheep there in 1838; 242,055 in 1841; 2,600,000 in 1860; and over six

millions and a half in 1887. Queensland was also rather late to enter the lists as a wool-growing country, the number of sheep in the Colony in 1839 being only 4,000. By 1843 the number had advanced to 12,000 ; and in 1888 was 10,623,985. The highest quality of combing merino wool is grown in some parts of Queensland, that colony owning at the present time nearly 13,000,000 sheep. Western Australia possesses over a million and a half of sheep. From the early years of the century, Tasmania has been engaged in sheep-rearing, and in 1884 had 1,720,027 sheep. Next to New South Wales, New Zealand holds the most important position in the Australian Colonies as a wool-producing country. The number of sheep in New Zealand in 1884 was 14,056,266, and in 1888 15,235,561, the principal breed being the merino. The only other British Colony from which wool is exported in large quantities is Cape Colony, which in 1875 had over eleven millions of sheep, and has year by year largely increased its number. Taking the United Kingdom, the Australian Colonies, and the Cape together, they own about 115,000,000 sheep, representing over 600,000,000 pounds of raw wool.

While the imports of foreign wools into European ports have nearly quadrupled during the past quarter of a century, the aggregate number of sheep has slightly diminished. From 1860 to 1885 there was a

decrease of 22,151,353 sheep in Europe, the number being, for the former year 168,074,611, and for the latter 145,923,258. The number of sheep in the United Kingdom in 1864 was 32,960,000, and in 1885 30,086,200. This rate of decrease has continued. There were 702,538 fewer sheep and lambs in the British Isles in 1888 than in 1887.

France in 1885 possessed 22,616,547 sheep, including many different breeds, those of Picardy having a close resemblance to our own Romney Marsh species, while the sheep of Normandy are of large build, and yield a fine long wool. A much smaller, short-woolled breed is located along the western coast; and in the south, notably at Rousillon, there are large flocks, in which the merino element is strongly manifested. Since the days of Louis XVI. the Spanish breed has been more or less acclimatised in France, the famous establishment at Rambouillet having from that time to this maintained its reputation for the pure quality of its merinos. The first Napoleon also contributed in a striking degree to the augmentation of the merino flocks of France, a raid being made by his direction upon the Spanish folds, resulting in 200,000 of the animals being driven over the Pyrenees.

From time immemorial Russia has been celebrated for its wools, and grows the largest quantity of any European State. Russia proper contained 47,508,966

sheep in 1882; and Poland in 1875 had 4,180,122; giving a total for the Czar's European dominions of 51,689,088. A large proportion of these sheep yield only a coarse description of fleece; the Crimea, however, produces a fine wool, the introduction of the Spanish merino to that district having been effected by a French merchant, M. Rouvier, in 1802, aided by a loan of £15,000 from the Emperor.

Germany, with some 20,000,000 sheep, holds a prominent place amongst the wool-growing countries of Europe, the wool of Saxony being amongst the finest now in the market, the result of improvements brought about by the Elector of Saxony in the latter half of the eighteenth century, in judicious breeding from a small flock of merinos obtained from the King of Spain. The Hungarian plains have also proved a profitable settling ground for this famed breed. In 1775 the Imperial farm in Hungary received 300 sheep from Spain, and thenceforward the race prospered so well in the country that Prince Esterhazy was able at one time to boast the possession of 250,000 merinos. Austria had 3,841,340 sheep in 1880; Italy, in the same year, claimed 8,596,108; Sweden, in 1884, had 1,410,177; Denmark had 1,548,613 in 1881; 1,686,806 were placed to the credit of Norway in 1875; Portugal had, in 1882, 2,977,454; Holland's record for 1884 was 752,949;

Belgium's for 1880 was 365,400; Switzerland's for 1886 reached 341,632; Iceland in 1871 had 366,130; and Spain, the country which is entitled to the first place in the past history of the fibre, has fewer sheep to-day than France. The ancient Spanish proverb, "Sheep have golden feet, and wherever the print of their footstep is seen the land is turned to gold," has lost something of its old flavour as far as the Spaniards themselves are concerned. In 1878 Spain's return of the number of its sheep was 16,939,288.

Combining all these figures, which represent the latest available official returns from each country at the time of writing, we get at a grand total of 171,866,965 sheep in Europe, exclusive of Turkey, where the animal is much neglected.

As regards other foreign countries the means of obtaining information, with one or two exceptions, is insufficient. The United States had 48,322,331 in 1885, but the yield of wool is neither remarkable for weight nor quality. British North America, with its three million odd sheep, does not at present count for much in the wool record. Canada, indeed, does not produce more wool than it consumes. Large quantities of wool, good, bad, and indifferent, are grown in many parts of Asia and Africa, but, apart from Europe and Australia, the country which has come into most prominence in recent

years in the matter of wool production has been the Argentine Republic, the immense region of the La Plata valley.

It may be that in this Silver Country, with its awakening energy and unlimited resources, there exists the latent forces of a textile revolution of universal influence. Already the Argentine Republic is the country which ranks second in importance in the supply of wools, the chief portion of them being of the merino class ; and it is hardly too much to say that its capacity of production is such that at no far distant period it might grow a sufficient quantity of wool to employ the whole of the present textile machinery of the world. Naturally, an extensive development of the pastoral industry in that region would greatly reduce the price of wool everywhere ; it has in truth been foreshadowed by more than one far-seeing reader of the signs of the times that some day wool may be even cheaper than cotton, although the cost of fabrication must always be greater in goods made from wool than from those manufactured from cotton. In actual number of sheep the Argentine Republic holds the leading position, having 90 millions of sheep inside the frontier, and from 9 to 10 millions outside ; but the fleeces are lighter than those of Australia or Europe, weighing usually only about 3 lbs. per fleece in the grease ; still, the Argentine fleece is steadily increasing in

weight, being 15 per cent. heavier now than ten years ago, and, with better attention, may vie in most respects with that of Australia. The merino wool culture was not seriously embarked upon in the La Plata valley before 1826, when it began with the importation of good merino animals with German shepherds. Since then the development has been very rapid. In 1840 the number of sheep in the Argentine provinces was 5 millions; in 1850, 7 millions; in 1860, 14 millions; in 1870, 41 millions; in 1880, 61 millions; while the number for 1887 is, as we have stated, little short of 100 millions. Such a rate of increase, continued for another quarter of a century, and a relative improvement in the quality of the wool, would give such results as could not fail to have a mighty influence upon the world's textile industries. And there is no reason why this expansion should not be realized. The favourable climate, the extensive seaboard, the internal and arterial system of rivers, counted amongst the finest in the world, and the fertility of the soil, seem to give promise of a maturing of wool-production which shall eclipse the records of all the other wool-growing countries combined. The increase in sheep in the twenty years from 1864 to 1884 was 202 per cent. According to the official return for 1883 (since which time there has, of course, been a very marked

increase) there were 58 million sheep in the province of Buenos Ayres alone, of which number it was estimated that 32 million belonged to Argentines, 18 millions to Irish and Scotch, and 8 millions to other nationalities. There were 5,000 square leagues, or 33 million acres, occupied by sheep-farms, the land generally carrying two sheep per acre, or 13,000 to the square league, which is about double the weight of stock that lands in Australia carry. An ordinary Irish or Scotch sheep-farm of a square league counts 20,000 sheep, as our countrymen prefer to have the best lands, which bear heavier stocking than the rest. Such land costs about thirty-six shillings an acre; the capital represented by a small sheep-farm of a square league is about 100,000 dollars, and yields an easy income of 20 per cent.¹ With such prospects as these it would be strange if the Argentine provinces did not lure plenty of English capital to their productive plains.

The improvement in the quality of the River Plate wool has been the most telling point in its favour; formerly it could not be used in England except for common fabrics; now it comes to market with a clean, firm staple, and finds a readier sale at advanced prices; and the burr with which this wool is so largely intermixed has been successfully dealt with by new mechanical processes. Much

¹ Mulhall's *Handbook of the River Plate*.

depends upon the future condition of the political atmosphere in the Argentine Republic whether or not the prospect now held out will be consummated, for it is mainly due to the cessation of revolutionary troubles that the industries of the country have been able to make such rapid strides of late. In some quarters this foreshadowing is regarded as the cloud no bigger than a man's hand that begins to darken the wool horizon ; in others it is accepted as the augury of a wider development and a brighter future for the most ancient of our textile trades. Time alone can solve the problems that are thus presenting themselves, and perhaps the most important factors in their working-out will be, as in the past, the mechanical aids which invention may bring to bear upon the question. Many of the industrial difficulties which have arisen in times gone by have been effectually dispersed by improved machinery, and the newer conditions of supply will doubtless be similarly dealt with. Even now, certain obstacles to the manipulation of River Plate wool have been successfully surmounted by inventive skill in the preparatory processes ; and, on the other hand, the wool itself is becoming purer and better every year.

It has been estimated that, taking the population of the world at 700 millions, it would require a consumption of two and a half pounds per head per annum

to work off each new clip of wool. Statistics have been prepared also showing the variation in the consumption in different countries of fabrics made from wool. For instance, Italy does not use more than 4*s.* worth per head every year; Russia, cold as its climate is, only reaches 6*s.*; Germany, according to the latest available calculation, showed 9*s.*, but it is considered probable it has since risen to the English and Belgian level, which is 15*s.* per head. The highest European average is that of France, 16*s.*, but the Americans head the list with 19*s.*, though that is accounted for more by the higher cost than the greater actual consumption.

From the earliest records we find this beautiful raw material fulfilling its useful purpose in the work of clothing mankind, but it has been reserved for these later times to give it that fuller development which embraces the perfection of pastoral productiveness on the one hand, and the highest present limits of mechanical ingenuity on the other.

CHAPTER II.

WOOL AND ITS USES IN ANCIENT TIMES.

THE beginnings of the textile arts lie hidden in the impenetrable mists of pre-historic times. When, or in what manner, wool was first used as a material for clothing can never be known. Such evidence as we possess, and such deductions as we are enabled to draw therefrom, clearly show that it was the first fibrous substance utilized by man for the covering of his body. It is an easy flight of the imagination to picture the primitive people of the "morning lands," roaming with their flocks and herds amidst the luxuriant valleys of antediluvian days, and, as necessity arose, converting the skins of slain animals into garments. The fleece of the sheep would require such little preparation to adapt it to the first rude purposes of clothing that it is reasonable to suppose it would have the first claim in this connection upon man's attention. It is a more difficult matter to conjure up any likely conception of the methods that were originally employed

of manufacturing wool into cloth. It has been said that nature supplies suggestions for man in all his inventive aspirations, and it is a pleasing fancy to think that the spider, the earliest of all spinners and weavers, may have conveyed to the mind of some reflective shepherd of ancient days the first notion of a woven fabric. Be this as it may, man, with all his thousands of years of skilful inventions and ingenious appliances is still unable to fabricate a thread of such subtle fineness as that which constitutes the spider's web, although in some branches of the silk manufacture a very near approach is made to this attainment.

The Scriptural narrative contains many allusions to sheep and wool, yet there is in none of these any positive indication that a knowledge of textile manipulation existed prior to the Deluge. "Abel was a keeper of sheep," we are told, and that is all. But it is hardly probable that a people so far advanced in the useful arts as were the patriarchal races who saw and assisted in the building of the Ark—a people skilled in the methods of reducing iron or copper ore into its pure state, and of forging it into bolts, and bars, and plates—would be ignorant of the processes of spinning and weaving. Jabal, the son of Lamech, "was the father of such as dwell in tents and have cattle," we also read; and if we are to consider the

tents of those days as bearing any similarity to the Arab tents of later times, the reference may be taken as pointing to the existence of a woven fabric, rather than to a simple covering of skins. The Arab tent of to-day is composed of a compactly woven covering of black goats' hair, with sides of coarse wool, spun at home by the women ; and seeing the little change there is in the customs of these people from century to century it is possible that this may have been something like the tent-covering which served for Jabal and his tribe in the antediluvian world.

After the Biblical record has passed the period of the Flood, the testimony in support of the existence of textile fabrics of various kinds is greatly strengthened, although it must be borne in mind that long before Moses penned the first books of the Sacred Volume, and before Joseph fell into the hands of Potiphar, the Egyptians had attained to great perfection in the manufacturing arts. The ruins of the palaces, temples, and tombs of the land of the Pharaohs are still eloquent in their desolation with memories of this industrial greatness of thousands of years ago.

The circumstance referred to in the ninth chapter of Genesis, when Noah, overcome by wine, lay uncovered in his tent, and his two sons, Shem and Japheth, took a garment, placed it on both their shoulders, "and went backward and covered the

nakedness of their father," is indisputable proof that within a short period of the drying up of the Flood, when there had been no time to make new articles of this description, textile clothing was in use, and therefore must have been manufactured before Noah and his family entered the Ark. After that the references to woollen and linen fabrics in the Bible are numerous enough to foster the belief that the Israelites had a full knowledge of the textile arts, though being a pastoral rather than an industrial race, they were not required to exercise them to the same extent as more advanced nations. Of the raw material they had an abundance, and it is clear that it was utilized for the purposes of manufacture. Sheep-shearing is several times specifically mentioned by Moses, as for instance, in Genesis xxxviii. 13, where we read: "And it was told Tamar, saying, Behold thy father-in-law goeth up to Timnath to shear his sheep;" and in another chapter of the same book (Genesis xxxi. 19) we read that "Laban went to shear his sheep." In Deuteronomy xv. 19, it is forbidden to "shear the firstling" of the sheep. Then it is recorded (1 Samuel xxv. 4) that "David heard in the wilderness that Nabal did shear his sheep;" and in the pathetic lament of the prophet Isaiah we have a figurative allusion to the process: "As a sheep before her shearers is dumb, so he openeth not his mouth."

Again, when the festivities of the season were taken advantage of by Absalom to slay his brother Amnon, the record is, "And it came to pass, after two full years, that Absalom had sheep-shearers in Baal-hazor, which is beside Ephraim, and Absalom invited all the king's sons." The flocks of the Israelites must have been of considerable magnitude—of such extent as to testify beyond doubt that manufactures from wool were prosecuted on an extensive scale. It is related (2 Kings iii. 4) that "Mesha, King of Moab, was a sheepmaster, and rendered unto the king of Israel an hundred thousand lambs, and an hundred thousand rams, with the wool." Mesopotamia, Syria, and Tyre abounded with flocks. In the war against the Hagarites the Hebrews took 250,000 sheep, and Moses took 675,000 from the Midianites. The Psalmist is moved to rapture by the sight of the hills and downs "covered with flocks;" and Bozrah, Bashan, Bethlehem, Carmel, Edom, Galilee, Kedar, and Shechem are all associated in the Biblical record with the growth of wool.

As time went on, the Hebrews not only made ample use of wool as the material of their wearing apparel but exported the commodity in great quantities. The white wool of Damascus was held in high esteem at the fairs of Tyre, and the beauty and excellence of the wools of Phrygia and Lydia were

such as to gain them renown. We are likewise made aware of the fact that the operations of spinning and weaving were carried on by the Jews, though the references to these processes in the Scriptures are of the slightest. We have the allusion in the Book of Proverbs to the virtuous woman who "seeketh wool and flax and worketh willingly with her hands; she layeth her hands to the spindle, and her hands hold the distaff; she maketh fine linen and selleth it; and delivereth girdles unto the merchant;" and Moses, speaking of the furnishings of the Tabernacle, also makes notable mention of spinning. He says, "And all the women that were wise-hearted did spin with their hands, and brought that which they had spun both of blue, and of scarlet, and of fine linen. And all the women whose hearts stirred them up in wisdom spun goats' hair." The more complicated contrivance of weaving is only touched upon for the sake of poetic illustration. Job laments that his days are "swifter than a weaver's shuttle;" the staff of Goliath's spear is compared to a weaver's beam; and Delilah is represented as having woven the locks of Samson's hair into the web and fastened them with the pin of the beam.

The Egyptians favoured the linen manufacture, and were probably proficient in this art long before

the Hebrews acquired an understanding of the system of working up wool into fabrics. Even in Palestine linen cloth was looked upon as greatly superior to woollen commodities, as is shown by its being reserved for those taking part in religious observances. It was enjoined upon the Jewish priesthood that they should clothe themselves in garments of linen, after the manner of the priests of Egypt, and special injunctions were laid upon the Israelites against the wearing of garments of mingled linen and woollen, a regulation which Maimonides supposes was intended as an expression of disapproval, aimed at the pagan priests who attired themselves in mixed robes in order to propitiate the planets and bring down blessings on their sheep and flax. "Thou shalt not wear a garment of divers sorts, as of woollen and linen together," is one of the laws set forth in the 22nd Chapter of the Book of Deuteronomy; and amongst the statutes enumerated in Leviticus xix. 19, is an enactment of a similar kind, "neither shall a garment mingled of linen and woollen come upon thee." Woollen materials were in general use for all ordinary raiment, but for special occasions and special people, vestments made from the linen yarn and cloth exported from Egypt in such large quantities to the countries bordering upon the Mediterranean were preferred.

We read of Solomon having linen yarn forwarded from Egypt; and the Prophet Ezekiel makes mention of the "embroidered linen from Egypt" which the Tyrians "spread forth to be their sail." But even in Egypt, much as that country was given over to the manufacture of linen, there was no scarcity of wool or of woollen garments.

Turning now to other ancient lands we find the evidences of the growth and treatment of wool more distinctly manifested. Babylon, the most celebrated mart of ancient commerce, cultivated the textile industries with great success, the productions of the Babylonians from wool and other raw material being distinguished for the extreme skill displayed in their manipulation. According to Herodotus, the dress of the Babylonians consisted of a shirt of linen, hanging down to the feet, and over it a woollen tunic, while a small white mantle or shawl was wrapped round the body. Babylon was famed beyond all other countries for the richness and beauty of its robes, into the composition of which gold and silver are supposed to have largely entered. So costly were these garments that on one being inherited by Cato, he commanded its immediate sale, thinking it too costly to be worn by one who professed himself an enemy of luxury. We have Pliny's authority for the statement that Nero's

dining halls were hung with Babylonian cloth, the cost of which was 4,000,000 sesterces, equal to 32,000*l.* Whether these gorgeous textures were woven in the loom, embroidered with the needle, or painted, is not known, nor is it ascertained what were their component parts, but it is presumed that wool was to some extent concerned in their manufacture. Within the precincts of the capital were large factories for the production of textile fabrics, and there were also similar establishments in other cities of the province of Babylonia.

The Libyans were said to "abound in flocks," and the Coraxi, located near the Euxine, were skilful in the handling of the woollen fibre from which they produced carpets and shawls, and sent them to the markets of the *Ægean* Sea. Classical writers speak in glowing terms of the wool of Miletus, which was celebrated everywhere for its fineness. Tertullian says: "From the beginning the Milesians were employed in shearing sheep, the Seres in spinning the produce of trees, the Tyrians in dyeing, the Phrygians in embroidery, and the Babylonians in weaving." The poetic literature of ancient Greece and Rome is thickly strewn with references to wool and its uses in the days of the greatness of the two classic nations. Homer and Virgil are so minute in their descriptions of the growing of wool and the processes to which the fibre was subjected that we

are enabled to form a vivid conception of the treatment of wool in nearly all its stages by the aid of their inspired pictures. When we come within the luminous atmosphere of those days of splendour and luxury, we leave the cloudland of doubt and conjecture behind. We no longer halt on the threshold of the unknown, and exercise our minds with the deciphering of mystic signs and the drawing of inferences. We emerge into a midday clearness. On the far-reaching alluvial plains of the Nile linen cloth had been preferred to woollen, but in Greece and Rome garments of woollen were in general use, linen being worn by women only ; and until the introduction of silk tissues from the East, the dresses of the Romans were almost universally of woollen. The women of the higher classes, in both nations, employed themselves in spinning at their homes, and the example thus set was continued in the countries colonized by the Romans even down to the days when steam superseded the hand as the motive power. The spinster with her distaff is a familiar figure from the time of the frail heroine of Troy to that of the "sweet, pale Margaret" of the *Faust* legend ; from the days of Penelope to the period of the rustic maiden of our own English cottages—the damsel who now fills the part of grandmamma in many a British household, and points with a pride born of pleasant memories to the still-preserved relic of the days of happy spinsterhood.

The spinning of wool has been the occupation of queens. In our own country we have illustrations of this at the very beginning of our historic record. Was not the mother of Alfred the Great accounted a skilful spinner of wool? And did she not “instruct her daughter therein”? It is a wondrous “vision of fair women” this succession of glimpses that the ancient literature gives us of illustrious personages whiling the hours away in the manipulation of fleecy fibres. Some of the antique statues of Minerva represent the goddess with a distaff in her hand, and it was claimed for her that she invented the art of spinning. The Egyptians however accord this honour to Isis; while Semiramis, the Assyrian queen, is credited with the invention of weaving. When Alexander presented the captive Persian Queen, Lisygambis, with a garment of purple and wool, the conqueror endeavoured to assuage her grief and enhance the value of the gift in her eyes by telling her it was the work of his sisters. Augustus Cæsar wore no garment but such as had been made in his own house. Queen Arete is depicted sitting at the fire, distaff in hand; and the wife of Odysseus is represented at her door spinning the purple thread. Amongst the gifts bestowed upon the Emperor Basil by his foster-mother were some woollen fabrics from the Grecian looms, and Danielis presented him with a carpet of fine wool, “of a pattern which imitated the spots of a peacock’s tail,

and of a magnitude to overspread the floor of a new church." The Roman Emperors made great efforts to induce skilled foreign artificers in woollen to settle in the imperial city, and granted them special privileges.

Virgil devotes a large portion of the *Georgics* to a technical exposition of the various kinds of sheep and the methods then in vogue of treating the wool, taking special cognizance of the pastoral phase of the subject. Ovid, in his rendering of the story of the weaving contest between Minerva and Arachne, also shows us something of the nature of the woollen manufacture in ancient Rome. He says :—

“ Nor would the work when finished please so much
As, while she wrought, to view each graceful touch,
Whether the shapeless wool in balls she wound,
Or with quick motion turned the spindle round.”

A still happier allusion to this preparatory process is made by Catullus, in his poem on the marriage of Peleus and Thetis. He sings :—

“ The loaded distaff, in the left hand placed,
With spongy coils of snow-white wool was graced ;
From these the right hand lengthening fibres drew,
Which into thread, 'neath nimble fingers, grew.”

Quotations from classic pens might be given to a much greater extent were it necessary, but sufficient has been said to show that the Greeks and Romans, in the zenith of their power, looked upon wool as one of the

most important textile fibres. Its importance lay in its general adaptability to the requirements of the people. Linen was preferable for some purposes, and when the occasion demanded an unusual display of luxury of dress, silk was resorted to, but for ordinary wear wool commended itself above all other materials, having regard to economy and utility as well as to beauty of texture. There are many indications that the Romans took great pains to improve the breeds of sheep, and especially to produce wool of the finest quality. As far as regards the art of fabricating the fibre, the improvements they effected were not in any sense remarkable, considering the abundance of their resources. In truth it was not until the inventive minds of the eighteenth century concentrated their ingenuity upon the mechanical problems involved in the operations of spinning and weaving that any great change was wrought in these matters. It is to the Romans, however, that England owes much of its early knowledge of the art of converting wool into presentable fabrics.

We have it on the authority of Cæsar that the Britons, in some parts of the country were "clothed in skins"; it is, on the other hand, supposed that the people of the southern parts of the island were well acquainted with the dressing, spinning, and weaving both of wool and flax. It is surmised that they were instructed in these processes by a Belgic colony anterior to the

Roman invasion, for when the invaders came upon the scene there were two kinds of native cloth which took their attention,—the one a thick harsh cloth worn as a sort of mantle, and similar in many respects to the Scotch plaids; the other made of fine wool dyed in different colours, woven into chequered cloth and corresponding to the modern Highland tartan. The Romans appear to have established a factory at Winchester for supplying cloth to their army of occupation, and to have thus placed Britain on a level with Rome itself in this particular manufacture. But the Britons were in no haste to throw away their skins or leather coverings, so the conquerors for a long time practised the art chiefly for their own adornment. The evidences are that when the native wool came to be adequately dealt with it was not only in the fabrication of cloth from the felting kinds but in the making of articles answering in some respect to what we now know as worsteds. Favouring this idea, we have the statement of Dionysius Alexandrinus that “the wool of Britain was often spun so fine that it was in a manner comparable to a spider’s thread.” But important as the English wool trade may have become under the Roman dominion, it rapidly declined through the long period of unrest which followed almost down to the subjugation of the Saxons by William of Normandy. The early Saxon chieftains concerned themselves little with the indus-

trial condition of the people. War was their calling, and as they had generally plenty of work on hand in keeping other invaders from their shores, the immediate necessities of clothing sufficed for them. It is true, Edgar showed himself in some degree anxious to study the interests of such of his subjects as were traders in wool, for amongst the laws he promulgated was one that prescribed that a weigh of wool was not to be sold at more than half a pound weight of silver. A sheep and its lamb sold for a shilling in those days; and when Ina ruled over Wessex it was enacted that a fleece "should be 2*d.* in the market." So, by slow degrees, as the Saxon sovereignty became more firmly established, the arts of peace were resumed, and England began to make headway in manufactures. An ecclesiastical chronicler of the seventh century speaks of "webs woven with shuttles filled with threads of purple and many other colours flying from side to side, and forming a variety of figures and images in different compartments with admirable art," ladies of rank being engaged in the work, amongst them the four daughters of Edward the Elder, who had great homage paid to them by foreign princes because of their skill in these things.

At this time, and for a long subsequent period, the people of Flanders and Brabant were famed for their skill in the manufactures of wool and flax, and con-

temporarily several towns in Germany rose into commercial importance. In those days a large proportion of the wool grown in England was exported to the Continent, and fetched a high price, but as our own textile industries increased in value it was deemed expedient to put restrictions on the sale of British wool to foreign nations. There can be no gainsaying the fact that for several centuries England was greatly behind in the race for manufacturing supremacy, and that when at last the impulse was given to native effort by the introduction of Flemish artisans, who applied the most improved methods and taught our inefficient workers how to get finer results of texture from their wool, both monarchs and people alike awoke to the pressing need of fostering and developing such a valuable aid to the national prosperity. The precise period at which the Flemish weavers first came over to this country is a matter of obscurity. Some authorities maintain that William the Conqueror brought a number of them over in his train; but it is much more likely that they followed afterwards, when it had become evident that he was settled on the throne, their pursuits being so essentially those of peace. There were probably only few Flemings living in England in the Conqueror's time; but those who had ventured here would meet with such profitable employment that they would not find it difficult to induce others of their

fellow-countrymen to come after them ; and when, later on, in the reign of Henry I., an inundation swept over a large portion of Flanders, driving the people from their homes, many of them were glad to take refuge here, bringing with them a complete knowledge of the woollen and worsted manufactures as they then existed in the country where they had long been permanently established, and where they attained a degree of perfection unequalled in any other nation.

It is not until after the immigration of the Flemings that we are able to trace with distinctness the dividing lines between the woollen and worsted industries, though, as we have seen, it is pretty certain that these divisions existed even in Saxon times. The separation, howsoever brought about, is associated in name and history with the town of Worstead in Norfolk, where one of the early Flemish colonies existed, and where undoubtedly worsted yarns or fabrics were made by the Flemings. That the town gave the name to the manufacture, and not the manufacture to the town, is manifest from Domesday Book, which alludes to the place as being in existence in Edward the Confessor's time. Mr. McLaren is of opinion that the Flemings who settled in Worstead turned their attention specially to spinning, and produced a yarn which became famous under the name of worsted yarn ; and that the improvement introduced by them consisted in a better method

of straightening the fibres, which is the distinguishing feature of worsted thread ; adding that “possibly the improvement consisted in some rude method of hand combing.”

The first mention of worsted yarn that occurs in English official records belongs to the eighth year of Edward II. (1315), which testifies to a complaint being made to Parliament that the clothiers of Norwich who manufactured worsteds were making pieces twenty-five yards long only and selling them as thirty, the regulation length. Subsequent to that date the references to worsted are frequent enough to show that this particular manufacture was extensively carried on in other parts of the country as well as in Norfolk.

It is inferred from the mention of a pair of stockings made of say, a kind of worsted, and valued at the then large sum of three shillings, as being included in the wardrobe of William Rufus, that the distinction between woollen and worsted must have been well established in the reign of that monarch. In allusion to this Strutt says, “Amongst the earlier productions from the loom in this country may be placed the saies or says. We can trace this species of cloth as far back as the 11th century, and at that time it appears to have been a valuable article.”

Wool, in one form or another—as a material of exportation or manufacture, in the form of woollen or

worsted—has for many centuries been an important factor in England's progress, and though it was mainly due to the exertions of foreign settlers that we were first enabled to compete with other nations in the production of goods manufactured from wool, we have needed no help in more recent years to carry us ahead of all other countries in this branch of the useful arts. The part which the fleece of the sheep has played in the history of nations has been one of supreme influence and advantage. It has been a civilizing agent everywhere. Ancient fable and inherited tradition alike point to the estimation in which the fleece of the principal wool-bearing animal was universally held in remote ages ; and as its uses have been multiplied in later days it has not failed to strengthen its claims to the admiration and regard of man in a corresponding degree. Although we cannot carry our vision further back than historical record takes us—at which point, as we have seen, we find the textile arts in wide and active operation—we can at least imagine that in the ancient days, when a large portion of the people of Asia and Europe, as well as of some regions of Africa and America, were wholly pastoral, the main use for the numerous flocks was the utilization of their fleeces. A recent writer—Mr. James Bonwick—has gone so far as to suggest that the classical allegory of the Golden Fleece is capable of being interpreted in

the interests of trade, and assumes that it is merely "a version of how the Greeks got hold of an improved sort of woolled sheep from the sub-Caucasian region, thereby gaining in trade such golden results." Be that as it may, the Golden Fleece has from a very early period done good service as a symbol of brotherhood and an emblem of industry, as the noble order of the Golden Fleece, founded in 1429 by Philip le Bon, Lord of Burgundy and the Netherlands, and many subsequent organizations, have so notably proclaimed. One of the oldest of all traditions connected with the manufacture of wool, and of special interest in relation to our subject, is that which is associated with the name of Bishop Blaize, but as we refer more particularly to him and the commemorative festivals connected with his name in a later chapter, we need not make more special mention of him at this point.

CHAPTER III.

THE GROWTH AND VICISSITUDES OF THE WOOL INDUSTRIES.

DURING the long period of the Middle Ages, extending over nearly a thousand years—from the end of the fifth century to the close of the fifteenth—the progress of manufactures was slow. The tide of commerce, such as it was, flowed from east to west, but was a long time in reaching the shores of England. The feudal system, with its jousts and tournaments, its din of Paynim battle and clash of personal combat, spread itself over all the nations of the West. War was the chief wealth-creator, and few men found their way to greatness through the avenues of trade. Still, through the mists of error, superstition, and ignorance which then obscured the path of progress, faithful bands of workers were to be seen here and there struggling towards the light, and wherever there was a marked industrial development wool was an important feature. It was due to the monks that

humanizing influences were brought to bear upon the strife and turbulence of the times. Under their pious guardianship, manufactures as well as husbandry were fostered, and monastic guilds of handicrafts arose which sufficed to establish trade on a firmer basis. As the advantages of these protective measures were realized, the principle was extended, and persons engaged in the working of wool in the larger towns applied to the head of the State for power to form guilds of their own. This species of trade-unionism, necessary enough perhaps in the rude condition of society then existing, exerted a vigorous control, and while it to a certain extent favoured monopoly and persecution, had the effect of concentrating and giving direction to industrial efforts which had previously been scattered and intermittent.

It was difficult, however, for any steady advance to be made. They were making history in those days, and the demands of war often suspended the operations of industry for long periods. The game of conquest was for ever being played; princes and their subjects were constantly fighting the battles of nations, and nobles and their vassals were as constantly engaged in private conflict. An era so exclusively military in its character had not been known since the Homeric age. But civilization was not to be kept back. Rome fell into decay, and the remnant of her Imperial fame was

represented by an effete dynasty at Constantinople. Then, from the Arabian wastes a band of Saracens swept over the countries bordering upon the Mediterranean, and obtained a larger dominion than had been owned by the Romans. Another wave of conquest set in from the East, borne forward by the Turks; the Moors made a descent upon Spain; and the Arab was the master of the greater part of Europe. The wars of the Crusades brought the West and the East into bitter contention, lasting over 200 years, but while the warriors of the Cross were bravely employed in rescuing the holy places from the sway of the Infidels, they found themselves in contact with a superior condition of textile resources and commercial knowledge than they had left behind at home. That they profited by what they saw is evidenced by the expansions of trade which followed their return. The first to take advantage of the new demands which sprang up were the Venetians and the Genoese, who, together with the Pisanese and the traders of Marseilles and Barcelona, became the purveyors of food, clothing, and arms to the Crusaders, carrying their enterprise so far as to found settlements and erect factories even in the land of the enemy. The Italian Republics touched a higher point of commercial greatness than had ever been reached before, but they in their turn declined, as the maritime discoveries of the fifteenth century extended

the sphere of trade and provided more Western nations with those opportunities of trading which their adventurous spirit and hardihood well enabled them to utilize.

It is apart from our purpose to trace the general evolution of trade in its westward growth. A brief glance at the part played by wool in that development must suffice. Spinning and weaving continued to be domestic occupations down to a comparatively recent date. Charlemagne had spinning schools on his estates, where all the processes of the woollen manufacture were practised, and where the manufactured fabrics were made into clothing. At these establishments English wool was largely used, and so highly did the Emperor value that commodity that he specially exempted merchants dealing in it from the peril of capture in war. We have already alluded to the celebrity attained by the Flemings in the exercise of the industrial arts in mediæval times—a celebrity so distinct that it was a popular belief in other countries that it was the outcome of some heaven-endowed gift. For several centuries—dating from about the middle of the tenth, when Earl Baldwin induced some weavers from Ratisbon to settle in his dominions—Flanders was the chief centre of textile operations in Europe. Thence came the weavers who succeeded in improving and giving vitality to the manufactures of England and

other countries. The importance of these arts in various parts of Europe in the Middle Ages is manifested in many ways. It is said that at one time 50,000 citizens of Brussels were dependent upon manufactures, and that in Ghent there were not less than 40,000 weavers. Cloth-weaving was also extensively carried on in the Northern Netherlands, then known as Friesland, the products of the Friesland looms being so greatly esteemed as to be mainly reserved for the mantles of princes and courtiers. Germany consumed a considerable quantity of English wool, and many of the knights who went from Dantzic, Elbing, and Thorn to fight with the Crusaders were cloth-merchants as well as soldiers. The Florentines, at the zenith of their power, did much to encourage the woollen manufactures. In the fifteenth century they could boast a productive capacity of 80,000 pieces or rolls of cloth per annum. They claimed a higher commercial position than that of the rival republic of Venice, and in the chronicle of Benedetto Dei we find special stress is laid upon their superiority in the textile industries. "Know that we in Florence have two guilds," he writes, "which are more estimable and noble than any in your city of Venice ; we mean the woollen and cloth manufactures. They are known in the court of Rome as well as at that of Naples, in Sicily, and at Constantinople, Pera, Scio, Bursa,

Gallipoli, Saloniki, Adrianople; and wherever the Florentines send their cloths, there they have banks, chambers of commerce, agencies, and consulates." In Spain, so celebrated as a wool-growing country, the art of manufacturing the fibre is said to have been largely exercised prior to the invasion by the Saracens. There is no doubt however that the conquerors engaged themselves to a very important extent in improving the industry, and that they succeeded in establishing it on a firm footing, large industrial colonies of Moors existing at Seville—which had 16,000 looms—Barcelona, Perpignan, and Tortosa. With the expulsion of the Moors, Spain lost the woollen manufacture, or the most part of it, and has never since regained eminence in that trade. The simple growing and exporting of wool is much more to the liking of the indolent natives of sunny Spain than the manufacture of it. France, both before, during, and after the reign of Charlemagne, interested itself greatly in the woollen industries. During the Dark Ages, when commercial enterprize was stagnant, the only manufacture that kept its position was the making of coarse woollen cloths from Barbary wool. Languedoc became famous for its wool fabrics, and the beauty of their dyes caused them to be much sought after. Holland was by no means an unimportant contributor to the manufacturing aggregate. Dort, Horn,

Haarlem, Leyden, and Delft were all more or less occupied in the production of cloth ; and at Middelburg, in the fourteenth century, there was a staple or market for the wool trade, raw wool from England being admitted free from duty ; and to this mart came merchants from many countries.

It will have been remarked that it was not until towards the close of the Middle Ages that manufactures began to attain any great influence, and that they were established in most countries before they made their way to England, where (at all events so far as they were connected with wool) they were destined to reach a higher degree of perfection and a greater productive power than in any other country. Indeed, from the period of Edward III. when, owing in a considerable measure to the successful operations of the various Flemish settlements, the woollen and worsted manufactures assumed a dominant importance, the history of wool, woollens, and worsteds becomes so much a matter of English record that we need not diverge far from the limits of our own industrial dealings to comprehend nearly all that has been done in these branches of the textile arts.

It used to be claimed that Edward III. was really the founder of the woollen industries of this kingdom, but the light which more recent historians have been able to throw upon previous periods clearly demonstrates that

although that monarch may be regarded as the great reviver of those trades, they had made no small progress under earlier English kings, notably during the reigns of Henry I., Stephen, and Henry II. It is certain that from the time of the Conqueror much of the wool grown in this country was fabricated into cloths and stuffs, and under Henry II. numerous guilds of weavers were constituted. The unsettled condition of the people in the reigns of King John and his son Henry III. caused the British textile manufactures to decline ; to such a low ebb had they fallen that even during the fairly peaceful reign of Edward I., who was not unmindful of the value of the industrial arts, they remained in a very depressed condition. A partial revival took place under Edward II., but it was the third Edward who, perceiving the important bearing of manufactures upon the fortunes of his people, adopted measures to secure their further development. Upon this matter the anonymous author of a book called *The Golden Fleece*, published in 1599, and alluded to by Youatt, is entitled to be heard.

He says, " The wools of England have ever been of great honour and reception abroad, as hath been sufficiently witnessed by the constant amity which, for many hundred years, hath been inviolably kept between the kings of England and the Dukes of Burgundy, only for the benefit of the wool ; whose

subjects, receiving the English wool at sixpence a pound, returned it (through the manufacture of those industrious people) in cloth at ten shillings a yard, to the great enriching of that state, both in revenue to their sovereign, and in employment to their subjects, which occasioned the merchants of England to transport their whole families in no small numbers, into Flanders, from whence they had a constant trade to most parts of the world. And this intercourse of trade between England and Burgundy endured till King Edward III. made his mighty conquests over France and Scotland when, finding fortune more favourable in prospering his achievements than his alledgeate subjects were able to maintain, he at once projected how to enrich his people, and to people his new conquered dominions; and both these he designed to effect by means of his English commodity, wool; all which he accomplished, though not without great difficulties and oppositions, for he was not only to reduce (bring back) his own subjects home who were, and had long been settled in those parts, with their whole families, many of which had not so certain habitations in England as in Flanders; but he was also to invite clothiers over to convert his wools into clothing (and these were the subjects of another prince), or else the stoppage of the stream would choke the mill, and then not onely clothing would everywhere

be lost, but the materials resting upon his English subjects' hands would soon ruine the whole gentry and yeomanry for want of vending their wools. Now, to show how King Edward smooth'd these rough and uneven passages were too tedious to this short narrative, though otherwise in their contrivance, they may be found to be ingenious, pleasing and of great use.

“ But this it must be granted, that King Edward was wise as well as victorious, for upon a visitation made by himself to the Duke of Burgundy, during his residence there, he employed such able agents among the Flemish clothiers, as (barely upon his promises) he prevailed with great numbers of them to come into England soon after him, where he most royally performed those promises, in giving not only a free denization to them, but he likewise invested them with privileges and immunities beyond those of his native subjects, which peculiarities their posterities enjoy to this day. But for the more sure establishment, and before these preparations came into effect, King Edward upon his return, called a Parliament, and that in the beginning of his reign, where he so wrought with the Commons-House, (who had not the least knowledge that the King had moulded the design) as after long debate (which all motions in the House ought to undergo) it was presented to the Lords, and so to the King, who, among other *objections*, urged the loss

which must necessarily befall his revenue, as well in respect of the outward subsidy of a noble upon each sack of wool, which was to be transported, as of the inward custome which the cloath paid upon return, according to the rates then established. But these soon met with an expedient, for the cloath in time to come must needs yield a far greater custome upon that which was to pass into all parts of the world from England, than it could do upon that small return which came onely to the service of England, and therefore from the wool which from that time forward was to be wrought in England, and of which none in any sort, without the King's especial license, was to be transported, the Parliament gave unto the King a subsidy of a noble upon a sack. Seventy families of Walloons were in the first year brought to England by the invitation and promises of Edward. He kept his royal word to all of them. The greater part were at first settled in Kent, but they were by degrees removed to different parts, and scattered over the whole of England. They shifted their residence according to the facility with which they could obtain water or fuel, or the material on which they worked. The greater number finally settled in Yorkshire, Gloucester, and the Western counties."

Edward's policy proved very beneficial to the country. A number of prohibitory enactments served

the purpose of fostering the native manufacture until it grew to such importance as to render the removal of the restrictions advisable. The exportation of English wool was expressly forbidden, the importation of foreign cloth was rendered illegal, no subject was permitted to wear cloth that was not of native manufacture, and a tax of 20s. per sack was laid on all wool employed in home manufacture. So matters continued for some years, during which time Edward's treasury would often have been exhausted but for the replenishing power the wool imposts gave him. When however the trade had become firmly established he ventured to relax his hold considerably, and almost went the length of introducing free trade, allowing exportation of British wool to all countries, and the importation of foreign cloth into England on the payment of a certain tax. The prices realised for English wool on the Continent at that period were very high, as much as 3s. a pound being obtained for large quantities in Flanders and Brabant. It is related that Queen Philippa's crown was redeemed from pawn at Cologne, in 1342, by the king sending a sufficient quantity of wool over to produce the required sum, 2,500*l.*, the price at which it sold being 1*s.* 3½*d.* per pound. The method of weighing wool had hitherto been by means of steel-yards, but the system being capable of allowing considerable fraud, it was abolished in 1352.

After the redemption of Queen Philippa's crown, and in little more than ten years, over thirty thousand sacks of wool were exported, or, given in other figures, eight million and a half pounds. Edward by his levy added very largely to his treasury—to the extent, according to Anderson, of what would when he wrote be equal to three and a half millions sterling. It is interesting to note the variations of the different levies that were made in the earlier history of the wool industry. At the close of the thirteenth century the value of the commodity was estimated at about half that of land, and the levy was 40s., but half a century later it was as low as 6s. 8*d.*; four years later it suddenly jumped to 2*l.* 10s., only to be reduced however in 1362 to 26s. 8*d.*

The fourteenth century was remarkable for the first exportation of manufactured goods. At this period the art of worsted spinning had made much progress in England, Norwich apparently being the cradle of the industry. Norwich, indeed, played a very important part in the development of the worsted trade. The prosperity of the city was greatly advanced by the introduction of the "mystery" of weaving which the Flemish refugees brought with them. For fully two centuries this textile art was prosecuted there with more or less success, but in the time of Henry VIII. it had reached a low ebb and

seemed to be on the point of extinction. Plague and fire were partly responsible for this decay, but one of the principal causes was the improvement of manufactures abroad, which led to the raw material being again sent over to Flanders. Under Elizabeth, fresh encouragement was given to the Flemish artisans to settle in this country, and Norwich again began to benefit by the superior knowledge of these exiles from the Low Countries. Letters-patent were granted, on the 5th of Nov. 1565, permitting the "strangers" settled at Norwich to manufacture such "outlandish commodities as hath not bene used to be made within this our realm of England," as "therty Douchemen of the Lowe Countrys. . . . beinge all householders or maister workmen," with their families; the whole number of the settlement being restricted to three hundred. Four years later this number had increased to three thousand; while in the five months' plague of 1578-1579 the deaths among them amounted to 2,482, about a third of their then numbers. But the foreign refugees were not regarded with unmixed favour by the British workman of the sixteenth and seventeenth centuries. They met with much local opposition, and were compelled to seek the protection of the central Government; which, while well disposed towards them both on commercial and religious grounds, was hampered by the fear of offending

Philip, and by the Queen's aversion to anything that savoured of rebellion. The hospitality which had been offered the Flemish weavers was not disinterested. It was only with the view of utilizing their skill to the advantage of our manufacturing prosperity that they were welcomed to begin with, for when trade was bad, and it was found that there was not sufficient employment for the whole of the manufacturing communities, the foreigner was made to feel that he was in the way. In response to a local petition, the Privy Council, in 1571, issued instructions that no greater number of strangers should be allowed "than may stand charitablye with the meale, or at the leaste without damage of the natural enhabitants" of the towns in which they resided. This led to forty-eight refugees being selected at Norwich as "mete to be sente away owte of the realme." But as time went on this spirit of opposition was relaxed, and ultimately the descendants of the original Flemish settlers became part of the English people, and the only evidence of the alien strain that remains is in the perpetuation of some of the old Flemish names. From Norwich the manufacture of worsted yarn extended throughout the whole of the country; through Suffolk and Cambridgeshire southward, to the midland counties in the west, and in the north to Yorkshire. Berkshire had a considerable share in the development of the

wool industries towards the middle of the sixteenth century. John Winchcombe—or “Jack of Newbury,” as he was popularly styled—had a hundred looms in his house, and the hundred workmen that he employed were equipped at his own expense and led by him to Flodden. He was the first of our woollen princes, and achieved for his goods a wide distinction. They were almost as well known at home as abroad. William Damosell, English Envoy at Antwerp in 1549, wrote thus to the Lord Protector Somerset:—“I find wondrous little profit to be had presently, either in cloths or kersies.” But, as the Protector had just then to provide for the payment of a considerable sum to the Antwerp money-lenders, and might find it expedient to send to the Antwerp market some English fabrics, he adds: “it shall be best to have hither 1,000 of Winchcombe’s kersies.”

The raw material experienced many vicissitudes from time to time in regard to official regulation. In the Parliament of Richard II. “The Lords and Commons fearing lest by the continual grants of the subsidies of wool the same would grow into custom, and so be challenged by the king as of right; for avoiding this granted the like subsidy of wool as was last granted, from the feast of the Circumcision until Candlemas then following, so as the space between Christmas and the

Circumcision should be an interruption to the king's claim if it were attempted."

In the thirteenth year of the same monarch's reign exportation was again prohibited to the "natural subjects of the kingdom," and the privilege was granted only to a few favourites and foreigners. This had the effect of cheapening wool. It might be bought at 3*s.* a stone, while the grower himself did not get more than 2*s.* for the same quantity. Exportation was, under these circumstances, forced upon the king. Had he not acceded to the demand of the wool growers, he would have been involved in an insurrection. Immediately, in one twelvemonth, nearly fifty million pounds weight of wool was exported.

It was about this period that the price of British wools began to decline generally, owing no doubt to changes in fashion and to a resultant change in the character of the breeds of sheep in France, in the Netherlands, and in England. Nevertheless the long wools continued to maintain their position of superiority, and the animal was next exported. The British sheep-owner was the sufferer in this connection, and a statute passed in the reign of Henry VI. has the following preamble:—"Whereas divers persons have from time to time carried out of the realm great numbers of sheep with fleeces into Flanders and other countries beyond the sea, and there shorn them and

sold both the sheep and the wools, and thus the number of such sheep in the said country of Flanders is likely to be much increased, and the custom of wool lessened, and the price of wool abated," &c., therefore under forfeiture of the animal the exportation was prohibited except under special licence. Under Queen Elizabeth this statute was not considered sufficient ; penalties were added to confiscation, such as a year's imprisonment, and the loss of the left hand !

Scotland exported wool to Flanders in the middle of the fifteenth century, and although the article was not so fine as the English material, yet it served for numerous manufactures. About the same time the King of Portugal applied to Henry VI. for liberty to export sixty sacks of Cotswold wool to manufacture cloths of gold for his own use. In 1581 the exportation of Scottish wool was interdicted, and in the following year the general exportation was for a time suspended. Less wool for the foreigner naturally meant increased manufacture at home ; sheep were more largely cultivated, the flocks of the farmer increased, the fleece was better, and there was an improved feeling all round ; the interdict was however suspended when the Netherlands were more pacifically settled, although similar prohibitions were frequently made subsequently. For instance, James I. in 1604 prohibited the exportation of wool entirely ; in 1639, in 1647, and in 1661

prohibitory enactments were passed. In 1666 Ireland was allowed to export the commodity, but before the end of the century restrictions were placed upon the exportation, limiting it to certain western ports. The exportation was allowed from all parts of the Irish coast; but the regulations were severe, and the penalties of infringement extreme. In the same year exportation was forbidden to the British colonies of America—an edict apparently inspired by the jealousy that the communities in those latitudes might start competitive manufactures with England. The export which we have seen was prohibited to all British subjects in 1662, was allowed in 1788 to the West Indies.

The importation of wool to England took place early and from various countries. Jamaica, Maryland, and Virginia were among the first to send considerable shipments. Spanish wool was the largest importation, however. In 1730 it amounted to 1144 bags; in 1788 it amounted to over four million pounds weight; in 1794 the importation fell to less than two million pounds weight, while four years later it rose again to more than four million and a half pounds. Alpaca wools were first brought here at the commencement of the present century, although not adopted to any appreciable extent until Mr. (afterwards Sir) Titus Salt took this fibre in hand and established its manu-

facture with eminent success towards the middle of the century.

We must retrace our steps a little to consider some of the earlier processes of the manipulation of the wool. Knitting was one of the first uses to which it was devoted, and the stocking-frame invented by the Rev. William Lee of Cambridge created an important epoch in the history of British industry. With the curious perversity of fortune which seems always to have dogged the steps of first inventors Lee was ruined by his. At home or abroad it was the same, and he died a beggar. His workmen however lived long enough to see worsted hosiery established as an important element of our manufactures.

The East India Company proved a friend to British wool-growers, and in fact in certain classes of goods they exported it was made a *sine quâ non* that they were manufactured entirely of British wool.

One of the necessary arts in the manipulation of woollen goods was that of dyeing, and it is singular that in a country where several hundred years previously there were experts in the craft there should have been a prevailing deficiency in the time of James I. Our manufactured cloths were then sent abroad to be dyed ; we were unable to finish what we had in a sense created. Sir Walter Raleigh animadverted upon this in his *Essay on Commerce*, and he made proposals to

the king to monopolize the dyeing and dressing of the materials. James acceded to the proposal, and as a consequence issued a proclamation prohibiting the exportation of any white cloths beyond the sea. Holland and Germany naturally retaliated ; they refused to have any imported dyed cloths, which were necessarily forced back upon the home market. For a period the Hollanders triumphed ; but the advent of a dyer from the Netherlands, who had the assistance of the Government, contributed to the desirable consummation of making us independent of the Continent. In the meantime medley cloths had been introduced from Gloucestershire ; they were a mixture of different coloured wools in the thread.

In the reign of Elizabeth most of the wool produced in the country was used up in manufactures, either for home or foreign consumption, but during the *régime* of James there appears the following confession under the sign-manual : “ that the cloth of this kingdom hath wanted both estimation and vent in foreign parts, and that the wools are fallen from their stated values, and trade in general is so far out of fame that the merchants and clothiers are greatly discouraged.”

Charles I. when he came to the throne neglected to show any interest in manufactures. He complained during his first year of the low state of wool, and the decay of the woollen trade ; but, as Youatt believes, he

was aiming at the same object which was paramount with his father, the increase of the revenue by new imposts. Prohibition of exports of wool again held the field, and it was "ordained that all black cloths and mourning stuffs at funerals should be made from British wool alone." Prohibition after prohibition, and penalty upon penalty, were made. To the merchant adventurers, Charles delivered up the whole trade, and no manufactured goods were allowed to be sent to other than their mart or staple towns. The "staple" was originally the designation of the emporium at which the commodities of wool, cotton, or flax were sold, and so early as 1313 there is a record of the patent ordaining a certain place on the Continent as a "staple for the merchants of England." A second patent was in "favour of the mayor and merchants of the staple," while a charter in Edward II.'s reign sets forth that "as the merchants, native as well as foreigners, made a practice of carrying the wool and wool fells (fleeces) bought in his dominions to several places in Brabant, Flanders, and Artois for sale, he, in order to prevent such damages, had ordained that all merchants, whether natives or foreigners, buying wool or wool-fells in his dominions for exportation, should carry them to *one* certain staple in one of those countries, to be appointed by the mayor and community of the same merchants of his kingdom, who might change the

staple if they thought it expedient." Antwerp was a first staple ; but, with the erratic changes which most kings displayed about this period, a declaration was soon issued, stating that no "locality on the Continent was to be henceforth the centre" of the wool trade. English towns were appointed, such as Cardiff, as the places for such sales. A few years later foreign towns were again added to the list, while the traffickers in this branch of commercial enterprise at home eventually concentrated themselves in Leadenhall Market, Bermondsey, &c.

Besides the arbitrary powers conferred upon the merchant adventurers by Charles, regulations were made by which no one was allowed to trade within their limits under penalties and forfeiture, and for such rights the merchant adventurers increased Charles's exchequer at one time to the extent of £30,000. It is almost beyond comprehension how the woollen trade succeeded in triumphing over such oppression. But commercial interests were not held in particular regard, and even under the Commonwealth there was little accomplished to relieve pressing disabilities. It is not surprising, under these circumstances, that Continental Governments should have taken advantage of our apathy in such matters. English commerce was seriously menaced by Colbert, who "offered immunities, and indulgences, and premiums, and pensions to manu-

facturers and artists of every description, and from every country." Florence set up its manufactories, as well as other places, with a result that our woollen trade went on declining. The Stewart Government never attempted anything to retrieve it; the landed interest also contributed largely to the development of the foreign against the home trade—they forced up the price of wool so high as to drive our own manufactures out of the markets abroad.

Sir Josiah Child, in his "New Discourse of Trade," published about 1670, has some earnest words to say "concerning wool and woollen manufactures." After observing that "wool is eminently the foundation of the English riches," and urging that all possible means ought to be used to keep it within our own kingdom, he points out that despite the passing of a law making it felony to "ship out wool, woolsels, &c," yet "we see that English and Irish wool goes over so plentifully that it is within a very small matter as cheap in Holland as in England." He then addresses himself to the question of prohibitory measures, and says, "But some may then ask me, whether I think it would be for the advantage of the trade of England, to leave all men at liberty to make what cloth and stuffs they please, how they will, where and when they will, or of any lengths or sizes? I answer; Yes, certainly in my judgment it would be so, except

such species only as his Majesty and the Parliament shall think fit to make staples, as suppose Colchester Bayes, Perpetuances, Cheanges, and some other sorts of Norwich Stuffs, to be allowed the honour of a public Seal, by which to be bought and sold here, and beyond seas; as if it were upon the public faith of England; and wherever such seal is allowed, or shall be thought fit to be affixed to any commodity, I would desire, the commodity should be exactly made according to the institution, and always kept to its certain length, breadth, and goodness." Still, although the restrictions on wool were occasionally lessened, it was not until a comparatively recent period that prohibitions were wholly withdrawn. Our rulers and parliaments found it difficult to deal with so vexed a question, hence the spasmodic enactments, first on one side, then on the other.

Youatt gives some statistics of the number of sheep at various periods subsequent to 1688, and although he does not assert their absolute accuracy, yet he ascertained that they "approximated to the truth." In 1698 it was calculated that in Great Britain there were twelve million sheep, and that the wool annually shorn or felted, at the average of something more than three shillings a fleece, was worth two million sterling. The value of this was supposed to be quadrupled in manufacture, although we may take it it was not more than

three times the total of the raw material. The number of sheep had increased in 1741 to nearly seventeen million; the value of the wool was nearly three million sterling, and that of manufactured goods, supposing that all the wool was used at home (and from 1660 to 1825 export was forbidden), over eight million sterling. In 1774 the sheep numbered twenty-five million five hundred and eighty-nine thousand; the value of the wool was four million and a half sterling, and that of the manufactured goods nearly thirteen million. In 1800, according to a calculation of Mr. Luccock, there were upwards of twenty-six million sheep, and the wool from the now increasing weight of the fleece amounted to three hundred and forty-six thousand packs of two hundred and forty pounds each. The value was estimated at nearly six million sterling, and that of the manufactured goods at seventeen million and a half. Thirty years later Professor M'Culloch computed the number of sheep in the United Kingdom at thirty-two million; the value of the raw material at seven million; manufactured articles at twenty-one million sterling; and the number of persons engaged in the manufacture of the latter considerably over three hundred thousand.

The influence of machinery on the wool trade may be here incidentally adverted to. At the rate of pro-

duction in 1738, a million and a half persons would be required to work up the annual growth and importation of wool into cloths, whereas in rather less than one hundred years afterwards only three hundred and fifty thousand operatives were required.

The exports of the manufactured article increased with the spread of British dominion. The more the colonies grew in population and wealth the larger became our exports in this line, and of course the greater the demand upon our sheep industry the more were the resources of the agriculturist and husbandman taxed. More sheep required more food, hence arose the "artificial or turnip husbandry"; larger breeds were everywhere encouraged, for the increase of the carcase in weight rendered the fleece longer and the fibre larger. These circumstances contributed to bring about the change in the quality of British wool already sufficiently indicated in an earlier chapter. This change, and the competition to which the home sheep-owner became subject, led to a duty being imposed upon foreign wool; but, as most people will be ready to admit nowadays, it was bad policy, and the results were not such as had been looked for. As Youatt writes, "the duty operated as a premium on foreign manufactures." The home consumer would have his cloth made of the finer foreign wool, and the consequence was that until our home-grown article

was manipulated in different ways, much capital and labour was idle.

At length the Legislature threw over the barriers that imposed the restrictions, and the wool trade became altogether open. There was a flood of foreign wools on the English markets; but the consequence was an increase in industry, and therefore a further impetus given to the demand for all kinds of material. England was very soon unable to supply the markets of the world, and in the subsequent revolutions of commerce and agricultural development abroad she occupies only a comparatively subordinate position as a wool-growing community.

CHAPTER IV.

WOOL AND ITS MANUFACTURING PROCESSES.

AT this stage it will be well to make some reference to the different processes to which wool is subjected in being fabricated into cloths or stuffs, woollens or worsteds, and to endeavour to make clear to the untechnical mind the lines of divergence whence, on the one hand, wool passes forward for conversion into cloth, and, on the other, is put through the operations necessary to give it the character of worsted. In doing this we shall the better realize the important part which woolcombing plays in the work of textile transformation, so far as the worsted manufacture is concerned, and shall be able to concentrate our attention more particularly upon this one process, the remarkable mechanical development of which forms one of the most notable chapters of modern industrial history.

There was a time when it was sufficient to divide wools into two great classes, short wools and long

wools, clothing wools and combing wools, and when it was not altogether incorrect to say that woollens were made from one and worsteds from the other. This distinction, however, is no longer even approximately accurate, the mechanical contrivances of modern days having greatly extended the scope both of the woollen and the worsted manufacturer, giving the former command of wools that in former times would have been too long for his use, and extending to the latter an equal power over shorter wools which under the old system could not have been handled in the worsted processes. But there is another difference between wools for woollens and wools for worsteds that is perhaps better defined, and that is in regard to their felting or nonfelting qualities. Wools in which the felting properties are marked are mainly utilized for the making of cloth, while the wools which are deficient in these peculiarities are best adapted for worsteds. Youatt defines the felting nature of wool as "a tendency in the fibres to entangle themselves together, and to form a mass more or less difficult to unravel," and he explains that although this curl is obvious even in wool of the longest staple, it is more especially apparent in the fleece of the short-woolled sheep. All descriptions of woolly fibres, short or long, thick or thin, curly or straight, however, are nowadays employed in making woollen yarns ; but in worsted the

short and refractory fibres have to be cast out, while the curly threads are made smooth and straightened as much as possible. For woollens the fibres are placed in all directions, overlapping and crossing each other in every conceivable manner, while for worsteds they are laid in a parallel direction.

Before wool comes into the hands of the manufacturer, however, it has to be sorted, an operation performed by a workman whose tools consist of a pair of shears, a weighing apparatus, a pair of tressels, an oblong wire screen, and a set of wicker baskets. The sorting process is thus described by a well-informed writer :—“Setting his tressels open, he (the sorter) lays upon them his screen, disposes his baskets about his feet, lays the fleece on the screen before him, and, with scissors in hand, at once sets to work. Most fleeces are marked by the farmer with tar, generally on the rump; and as the tar will not yield to the washing, the wool to which the mark adheres is cut away, and thrown into a basket by itself.¹ Next, he takes away the inferior portions which grow on the upper part of the

¹ The use of tar is now fast being discontinued in all countries but Spain. There the sheep are left a great part of the year exposed to the rains, consequently a less adhesive substance would be washed off, rendering the task of separating the sheep of different owners an impossibility.

neck, the throat, the breast, the belly, and the lower part of the legs. But as this is not all of the same quality, part goes into one basket and part into another. The good wool is found on the thighs, the haunches, and the tail; and the finest of all at each side of the neck, on the shoulders, the ribs, and the back. There are usually about ten or twelve different qualities in one fleece. These are *picklock*, the very choicest of wool; *prime*, which differs very little from the first; *choice*, where the staple is still true, but coarser; *super*, much like the choice, but less valuable; *head*, from that part of the sheep, and the best of the inferior sorts; *downrights*, from the lowest part of the ribs; *seconds*, the best bits from the throat and breast; *abb*, inferior to the seconds; *livery*, chiefly the skirtings and edgings of the fleece; and *short coarse*, or—as it is sometimes called, from the locality whence it is obtained—*breech wool*. Without hesitating or halting, the sorter sorts away at his fleeces, takes just so much of each quality as he should, and throws each handful into the baskets around him. Of course, those containing the inferior sorts are most quickly filled, while many fleeces may be sorted before the *picklock* basket is full.”

This sorted wool finds its way, according to the quality and purpose required, to the hands of the

manufacturer. Various other preliminary processes are necessary before it gets into actual manipulation.

There are beating machines for the elimination of dust, burrs, twigs and the like from the fibre, and washing-machines for cleansing the wool. The latter consist of a range of long tanks communicating with each other, through which the wool is dragged by means of automatic forks, at every stage receiving an additional cleansing, and emerging at the other end clean and white. If the wool is not sufficiently dry it is next subjected to a drying process, and if intended for special purposes is bleached. After that the fibre is oiled, increasing its power of resistance, and making it more amenable to treatment. Machines of a very effective kind have been brought into use in recent years, capable of applying the oil much more evenly and completely than when the process was performed by hand.

These preliminary stages having been passed—and they are practically the same up to this point whether the wool is for woollens or worsteds—the short, or carding wool, for clothing, proceeds to the scribbler, and the long, or combing wool, passes to the gill-boxes where it is prepared for being combed.

Following out the cloth manufacturing processes,

we see the wool taken in hand by the scribbling machine, whose leading features are a series of large cylinders covered with minute teeth. These cylinders pass the fibre from one to another until all the filaments have become inextricably blended, yet presenting "a continuous ribbon of equal width, density, and weight." Then the carder—a machine on the same principle as the scribbler, but more delicate and searching in its operations—is brought to bear upon the wool, and when the fibre has passed through as many carding stages as required (usually not less than three) it is ready for the spinning processes. The stages are now from spinning to weaving, from weaving to fulling or felting, from felting to finishing; then the woollen fabric is completely built up.

Turning now to the worsted processes, with which we are more immediately concerned, we find that the three leading operations for the construction of worsted yarn are washing, carding, gilling, combing, and spinning. After the carding operation, the sole aim and purpose of gilling is to place the fibres in straight, smooth, and parallel directions. The principal parts of the gill-box are the fallers, which consist of bars of iron mounted with fine vertical steel pins, travelling on two pairs of endless screws, the upper pair carrying them forward, the lower

backward. As each faller reaches the delivery end of the box it is thrown on to the lower set of screws, and these convey it to the opposite end of the machine, where by the operation of an eccentric movement it is restored to the upper set. The wool undergoes the same process in a number of gill-boxes, receiving an additional refining touch at each stage, and as it leaves the final gill-box is ready for the combing machine.

Before making further reference to the combing machine, however, it is desirable that we should attempt to describe what woolcombing was previous to the introduction of the machine which so completely revolutionised this branch of industry.

The handcomber in combing wool under the old system employed two combs, one as a "pad" comb, fixed on a post at a convenient height, by an iron rod fastened into the post. The raw wool, after having been properly washed, oiled, and made up into handfuls—that is, the staples laid parallel upon a form or bench—was then "lashed" into each comb placed upon the pad. After each comb had been thus charged with raw wool, they were placed in the stove, or what was termed the comb-pot, to be heated, during which time the comber would prepare his handfuls of wool for the next charge. The workman then placed one comb upon the pad, and, with the

other in hand commenced the lashing or combing operation, each comb becoming a working comb alternately, by the teeth of one being made to pass through the tuft of wool upon the other, until the fibres of each became perfectly smooth, free, and clear of short wool, or noil, which latter was left embedded in the comb heads.

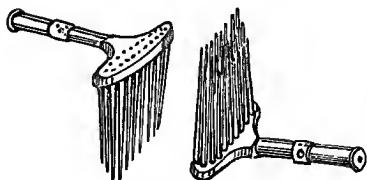

FIG. 1.

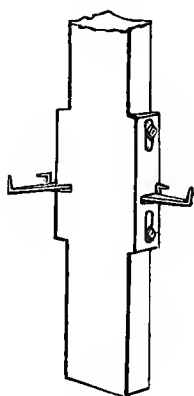

FIG. 2.

Fig. 1 shows such a pair of combs, and Fig. 2 a post such as described, the projections being adapted to serve for temporarily fixing the comb handles in during "lashing on." It will be noticed that the teeth are pointed and tapering, arranged in three parallel planes, the outermost row projecting beyond the middle row, and the middle row beyond the inner row. The pins, of steel, at their stumps, were fastened at about one third of an inch apart in

a wooden stock covered with horn, carried by the handle. The operation was commonly commenced with a comb of two rows, because of the greater enlargement at this stage. As in combing a lady's hair, so in combing a tress of wool, it was best to begin by combing the tips, and to insert the pins of the more sparsely provided part of the comb, and advance the combing operation progressively and more deeply from one end of the tress to the other until the teeth of the working comb were introduced and worked as closely as possible up to the pad or holding comb, with careful avoidance of actual collision between them. This procedure avoided rupture of the fibres of the wool and tearing of the ends entirely out of the combs, besides leaving no part between the combs of the tress of wool uncleansed. The short flocky wool left in the combs after the comber had drawn off with his fingers as much of the straightened combed and cleaned wool as he could take hold of, and had laid as evenly as possible into a sliver a few feet long, drawing through a bone-lined hole, was not further treated, but under the name of noil or noyls was disposed of for the blanket or coarse cloth manufacture, the long combed wool being called "tops."

It is the main purpose of the present volume to trace the various stages of development, from the

primitive method of woolcombing just described to the present perfection of woolcombing by machinery: therefore, while in succeeding chapters the progress of woolcombing invention is closely followed, from what it was to what it is, it is desirable that we should at this point attempt a description of the interior of a modern machine woolcombing establishment.

We cannot do better, perhaps, than take a well-known woolcombing establishment at Bradford for this purpose. The works cover a vast extent of ground. Their appearance from the outside is that of a well-built, symmetrical, and gigantic series of stone sheds, with the customary surroundings of tall chimneys, engine houses, offices, and workshops. The internal aspect is altogether different. Outside, a certain amount of repose seems to linger round the buildings, despite the buzz and clatter of machinery; inside, a world of noise, glitter and animation is revealed—wheels, pulleys, levers, cranks and arms, revolve, and chop, and slide, and rise and fall, with a firm and steady precision which no human action could equal; the stone floor, sturdy as it is, reverberates beneath one's feet, and on every side stand the evidences of a great and mighty force. From the woolcombing of the handcomber, with his "pad post" and his "pot-o'-four," to the opera-

tions of these wonderfully constructed machines, is an advance as great as the ingenuity of man ever achieved at one step—a transformation as complete as it is well possible to conceive.

Following the wool from its entry into the establishment to its final egress as combed fibre ready for the spinner, we shall best understand what the modern process of woolcombing accomplishes.

First, then, we descend into a large warehouse or cellar, extending under the entire length and breadth of the combing-shed, and presenting a perfect forest of iron columns. This immense room is crowded with bales and sheets of wool, just as they have been forwarded from the firm's different customers, for it must be borne in mind the firm do not comb wool for themselves, but work on commission for the trade generally, spinners finding it, as a rule, not only more convenient but more economical to put their wool out to be combed by such firms as these, who by devoting themselves entirely to this one process of combing are able to achieve results not always attainable by spinners who combine combing with their other operations. This vast underground storehouse is divided into separate compartments, or "rooms" as they are technically termed, the boundaries of which are easily marked by the avenues of pillars. These

“rooms” correspond precisely to similar divisions in the shed above. By this divisional arrangement each lot of wool is kept from first to last to its own series of “rooms.” To begin with, the “lot” is placed in a portion of the warehouse which is carefully boarded off and separated from everything else; and the wool is then emptied from the sheets and despatched up its own particular hoist into the corresponding division of the wash-house immediately above. Numerous workmen are engaged in superintending the reception and sending aloft of the mountains of wool which are for ever being built up and overthrown in this far-extending expanse, but the distances are so great and the piles of wool so high that the toilers seem almost as if hiding themselves from view. When the time arrives for a fresh lot of wool to be started upon, in succession to a lot that is passing through to the last stage of combing manipulation, it is taken out of its strong canvas wrappings, and spread out in all its fleecy confusion on the floor of the railed-off court prepared for its reception, and thence it is passed upward in such regular quantities as will insure the steady feeding of the machinery above.

We now ascend to the wash-house, and presently find ourselves at the head of the lift engaged in transferring the wool from below. The wash-house,

like the warehouse, is divided into sections, each section being provided with a couple of rows of washing machines and tanks, the rows being separated by a broad pathway down the centre of the "room." The washing machines are huge affairs, consisting of a series of tanks full of a warm soapy liquid, on the surface of which are placed at various stages sets of rollers, which as they revolve act upon the wool in the water, cleansing and purifying it as it advances. At one point revolving prongs dip into the fibre, like so many human fingers, and souse it in the lathery liquid ; at another the wool is squeezed through rollers which divest it of the dirt and impurity which the action of the water has loosened ; and so the wool passes on through tank after tank, and roller after roller, becoming whiter and whiter at every advance, until at last it reaches the far end of the machine, so shaken and wrung and cleansed that it emerges with hardly a taint or a touch of unwholesomeness about it. Beyond the feeding of the machine, there is little for human hands to do in connection with it, the operation being almost entirely automatic. The atmosphere is redolent of soap, and lather, and steam, and the men who look after the machines bear the signs of heat upon their faces and arms, although from their brawny and muscular appearance it would not seem that their

occupation is an unhealthy one. All down one end of the shed there are these wash-house sections, each with its couple of machines in active working, and a glance across these washing-day vistas is one of the most interesting sights that can be witnessed within the walls of a factory.

The next department of the shed, which is separated from the wash-houses by a series of high open archways, is devoted to the carding machinery. There are numerous rows of carders, stretching from end to end of the shed, and buzzing and whirring with terrible precision as they attack the newly washed wool with which they are constantly fed. It is unnecessary to describe this machine in detail, it is so well known and fills such an important function in other textile manufactures, being practically the same instrument as that which is used in the cotton and woollen manufactures. In few establishments, however, are these machines employed with such marvellous effect or do they excite so much wonder as in this mammoth woolcombing concern. Watching them as they take the fibre within their greedy jaws, as they break it upon their various wheels, rollers, and cylinders, as they shake from it all lingering foreign elements and *impedimenta*, and, at last, seeing the wool which entered the machine a tangled fleece delivered in the form of a dainty white film, it seems

as if the fibre had been converted into another material altogether. A white mist hangs over the cards, each machine sending forth its little cloud of gossamer dust. Perhaps the most surprising thing about these machines to the eye of the stranger is that they appear to be working away at an immense speed, turning off the filaments of wool, freed from knots and purged of impurities, with beautiful precision, but with little or no aid from the few work-girls who are scattered sparsely about to look after them. The wool is made to assume the form of a continuous filmy web by passing it on to the large cylinder, successively removing it by smaller ones, and replacing it on the main drum with all the filaments equalized. The cards are well fenced in, and as they perform their wondrous labours, row on row, they present a splendid example of sturdy mechanical force allied with the extremest delicacy of manipulation. Before turning from this stage of preparation it may be well to refer more particularly to the burring apparatus, which forms so important an adjunct to carding when the wools under treatment are of the kinds containing burrs.

Certain classes of wool—especially those known in the trade as Buenos Ayres wools, and coming from the La Plata Valley—contain a vegetable substance or burr, which has proved a great hindrance until recently

to the full utilization of these wools. The fleeces from some districts of Australia also suffer from similar *impedimenta*. For many years the burr was the wool manipulator's greatest difficulty. Various methods of treating it were adopted, but it was a long time before a really effective plan of removing it was discovered. It was the woolcomber's Gordian knot. While it remained unliberated it led to many troubles and defects in the work of fabrication. This burr is the yield of a vegetable growth of a most valuable character, possessing highly nutritive qualities, especially for sheep. It is spread over the entire sheep pasturage of the La Plata, and while the plant, which has its roots imbedded very deep down in the earth, beyond the parching touch of the sun's heat, affords sustenance through the seasons to the flocks that abound, its burrs or seed pods are scattered broadcast, and are found entangled, more or less, in every fleece. As sheep multiply in this region, the plant will be more largely consumed before reaching the seed stage, and the burr will gradually decrease. Ensheathed in the woolly fibres, the burr, which is from one to two inches in length, is rolled up in spiral form, somewhat in the shape of a snail's shell. When it comes under the action of the carding machine, however, it is straightened out and is laid more or less parallel with the fibres of wool; then in

the subsequent process of combing it assimilates itself with the wool (so far as the working is concerned) and is ultimately drawn off with the long wool "top."

It is in the spinning that the burr begins to assert a more positive antagonism to the animal fibre with which it has been accidentally allied, for owing to its thickness and inflexibility it presents features of obstruction which are not easily overcome. The burr takes the place of two or three fibres of wool, at the point of passage, and being unable, from its nature, to bear the tension that the wool is put to, constantly causes the thread to break; and even when this does not occur, the yarn is of unequal thickness and therefore seriously defective. The goods manufactured from burry yarns are wanting in evenness of texture, and, what is still more detrimental, the vegetable burr will not take the same dye as the animal fibre, consequently its presence greatly depreciates the value of the fabric. This drawback has been variously battled with, and may be obviated to some extent by having the goods "picked"—that is, the burrs extracted by hand before the finish is given to the "pieces." But this is a very costly proceeding, and often results in holes being left in the fabrics, which holes have to be repaired, at a further cost, and to the injury of the goods.

It was found absolutely necessary, if Buenos Ayres wools were ever to be properly utilized for European dress materials, that some means should be discovered of extracting the burr from the wool before it reached the combing machine. Many processes were invented and much money was expended in trying to attain this important end. The first mechanical method of separating the burr from the wool consisted in the addition to the carding engine of small rollers from which strips of iron plate were allowed to project. These rollers were set so that the edges of the strips were quite close to the surface of the card teeth, and they were usually placed upon the first opening or dividing rollers of the card, before the wool and burr were fully opened. The burring rollers were made to revolve at a high speed, and they struck out of the wool a considerable part of the vegetable matter which it contained. This was a great improvement upon previous methods; still it left much to be desired; the apparatus did not suffice to remove all the obstruction, many of the burrs were simply opened out and went forward with the wool while at the same time a good deal of wool was thrown off.

Another method of dealing with the burrs consisted in trying to destroy them chemically. The raw wool was steeped in an acid bath, or exposed to a great

heat, or both, in order to render the burr brittle ; it was then passed through crushing rollers, by which process the burrs were reduced to powder. It will be easily comprehended, however, that this system did injury to the wool ; but more than that, it affected the dyeing, making it difficult and uncertain ; hence the chemical mode of burr removal has not been very widely adopted.

A more recent and more effective plan was brought out and patented by MM. Harmel Frères in 1880. They, in conjunction with Mr. Jonathan Holden, of Rheims and Bradford, succeeded in mastering the main difficulties of the problem. Being convinced that it was not possible to extract or destroy every particle of the burrs while the wool was in its raw condition, they set about attempting to extirpate it after it had been drawn out and placed parallel with the fibres of wool. Having observed that the burr when fully opened was thicker and more crisp than the wool, they caused the wool, as it left the “doffer” of the carding engine—when it was in the form of a very thin web—to pass between crushing rollers, one of which was fluted, and the other smooth, their surfaces being so absolutely true that the edges of the flutes rent and cut the burr up into small fragments. The burr being of greater thickness than the wool fibres, and inflexible, lifted or received the entire

weight of the roller, while the fibres of fleece, owing to their fine, even, elastic, and animal nature, were untouched, or if touched, remained uninjured. In the double card these rollers were placed between the two bodies or cylinders, and a great number of these broken pieces of burrs fell out underneath. In any case, when the cardings thus produced came to be combed the short bits of burr remained with the short wool and passed into the "noil."

This process was adopted and applied on a large scale—by Harmel Frères at Val des Bois, and Jonathan Holden in his works at Rheims and Bradford—at the latter place under the firm of Holden, Burnley and Co.—and still more extensively at Roubaix and Fourmier, by MM. A. Prevoust et Cie, A. Vinchon et Cie, A. Motte et Cie, Demolin et Cie, and other houses. It was a great achievement, and conferred an immense benefit upon the general worsted trade, to introduce a method of extracting the burr mechanically, leaving the wool in its natural state, retaining all its softness, and in no way interfering with its spinning and dyeing qualities. Previous to 1880 the burry wools of Buenos Ayres were chiefly used for inferior purposes, and therefore their consumption was limited; indeed, at times they were quite a drug in the market. But now that it has been found not only possible but comparatively easy to manipulate wools from the vast plains of the

La Plata, we may anticipate a large increase in the business done with these fibres. The valleys of this favoured region are of enormous extent, and, for the rearing of fine wool sheep they possess advantages that are not enjoyed by any other country. It is but a question of time and capital to prepare these fertile lands for the accommodation of flocks capable of supplying the wants of the world in regard to wool. In fact wool as a raw material may at no far distant date be as cheap as raw cotton, though its processes of manufacture must always be more costly.

A further advance brings us upon the portion of the works with which we are most concerned—the wool-combing operations. There are rows on rows of woolcombing machines. As a piece of mechanism each of these machines is beautiful to look upon; the brightness of its appearance, the unerring exactitude of its movements, and the more than human dexterity with which it handles the fibre, all combine to excite admiration. To such a degree are these machines self-acting that one girl can easily attend to two of them. All that is required of her is to see that the combs are kept strictly clean, and that no obstruction is permitted to interfere with the ingress and egress of the woolly filament. The combs move round the machines horizontally, each separate comb forming a segment of a circle of combs, and being fed by a couple of feeders

which imitate the motion of the old hand-comber and rise and fall with great rapidity. Looking across these bright rows of combing machines, this continuous rising and falling movement of steel-teethed instruments constitutes an exceedingly striking picture. The horizontal combs convey the wool round to drawing-off rollers, and at that point the fibre issues from the machines in its combed condition—falling in white, lustrous, delicate filaments into tall tin cans placed ready for its reception. The beautiful operation, upon which so much human ingenuity, skill, and patience, and such a vast amount of money have been expended, is now complete. The wool is combed far better than it was ever combed by hand, and as it unfolds itself in gentle “slivers” from the machines, it lies with its fibres all tenderly smoothed out in one direction, and is free from all impurities. It now only remains for it to be handed forward to the gilling machines, which amalgamate the long and short fibres and roll the whole into convenient balls. The wool is now in the condition of “top,” ready for delivery to the customer who sent it to be combed.

Although, for the sake of illustration, we have alluded particularly to a woolcombing establishment on the square motion principle, the description would apply with equal force to a concern mounted with Noble, Nip, or Heilmann machines, the general plan

of operations being much the same in all establishments. The only difference of moment is in the machine itself, and even as to this the distinction between one class and another is not sufficiently apparent to the untechnical mind as to be immediately detected.

When the wool is received back by the spinner it undergoes the processes necessary to convert it into yarn; after that it passes to the loom, and as warp or weft, or both, is woven into pieces, and, finally, passes through the hands of the dyer and finisher and is ready for the market. Thus from year to year millions of pounds of wool are transformed from its native condition of the sheep's fleece, through a variety of ingenious mechanical processes, until in the end the fibre is enabled to take its place as the foundation of many beautiful fabrics for the use and adornment of the human race; and perhaps the most important of all the processes to which wool is subjected in its progress from the back of the sheep to the perfect garment, is that of its combing, and it is to trace the history of this process from the earliest period to the present time that this volume has been chiefly undertaken.

CHAPTER V.

THE CARTWRIGHT ERA.

THE earliest English patent dealing with the subject of woolcombing is that of Isaac Mills, of Belluton, in Somersetshire, who, in the year 1723, had a patent granted to him for an "instrument for heating combs for combing and pressing wool." Although his invention did not touch the question of woolcombing by machinery, a reference to it may be useful for the light it throws on the old handcombing methods at that date. In his application he represented that he had been "bred up in and followed the trade of wool kemming and pressing for twenty-five years," and he explained that "the usuall way or method for kemming of wooll was by a fire made in a clay pot; the fire being open to the kembs," which did "often neal the kembs and burn the wooll." It was further stated that "for the pressing the planks or iron plates" were heated "by a fire open to them," which often burned the planks and heated the iron plates "so unequally that it frequently burned the goods, to the great loss of

the tradesman and discredit of the woollen manufacturer." To obviate these difficulties he had "with great labour, pains, and expences," worked out his invention, which was described as "Two instruments of iron, to be used in the said trade of wool kemming and pressing, which are cast in such a forme and contrived in such a manner, that a fire being made in the body of the instrument of iron for kemming, the kembs receive the heat from the same in such an equal proportion as neither to neal the kembs nor burn the wooll; and that for the pressing, the planks or plates being placed in the body of the other iron instrument, and a fire being made to encompass or surround the same, will heat the planks or plates in so true a degree as wholly to prevent the burning of the goods, and the great loss frequently sustained by the traders in the woollen manufacture thereby." The importance of the invention in the eyes of the "trusty and well-beloved Isaac Mills" is sufficiently indicated by the further statement that he doubted not it would "prove of publick use and benefit to this our kingdom by the great consumption of iron the said invention would occasion, and to all persons concerned in the woollen manufacture."

No material improvement in woolcombing methods was effected, however, until towards the close of the eighteenth century, when Dr. Edmund Cartwright made the first practical attempt to solve the problem

of woolcombing by machinery—a problem which was destined to engage the minds of many inventive geniuses before it was successfully worked out. But to Dr. Cartwright belongs the merit of having, without the advantage of special mechanical training or knowledge, created the germ of all subsequent machines for the combing of wool. Some later workers in this particular field of invention have proceeded on lines distinctly their own, and even in ignorance of Cartwright's woolcombing achievements, but the leading principle of Cartwright's machine finds representation in all the others.

It is due to the distinguished man who was the pioneer of inventors of woolcombing machinery that we should endeavour to make his personality clear. His career was a remarkable one. Men who begin life as poets rarely end it as inventors, except in the fanciful sense. Yet so it was with Edmund Cartwright. Nature had endowed him with a many-sided genius, and a capacity of assimilation that enabled him to figure prominently in whatever development was in progress. In the days of his studentship at Oxford, it so fell out that he was brought into close contact with the poetic movement of the time, such as it was, and for a considerable period he devoted himself ardently to the cultivation of the Muses. The navy would have been his choice, but he had to forego the chance of entering

the lists with Nelson, in obedience to paternal authority, which destined him for holy orders at Oxford, whither he was sent from the Wakefield Grammar School, at the age of fourteen. He was placed under the private tuition of Dr. Langhorne during the vacations. Dr. Langhorne's name was well-known in the literary world, both as the editor of Plutarch's "Lives" and the author of some volumes of verse, and thought much more of the very smooth and very commonplace verse he wrote than of the vigorous prose which the world preferred. It was the period of poetic dulness ; the literature of the day did not show a single poet of the first rank, such as had thrilled the souls of a previous age, or as were to awaken the enthusiasm of a later day. It was a didactic age—an age of philosophy in heroic couplets—an age of Rosa-Matildaism. But there were writers who passed for poets in those days for all that, and who commanded the homage of the poetasters apparently quite as much as if they had been the true kings of song they imagined themselves to be. So Langhorne came to be considered a poet, and as Edmund Cartwright sat at his feet from day to day, and watched his communings with the invisible, he resolved that he too would be a poet, much the same as he might have resolved to be anything else had the example been there before him.

Young Cartwright was an apt and precocious pupil.

He soon began to measure out his fancies and philosophings into ten-syllable lengths, with rhymes to jingle them into acceptance, and before he had reached the age of nineteen the world had had a taste of his talent for versifying. Poetry was so eminently proper in those days that it accorded well with the priestly calling; and Edmund Cartwright looked forward to no greater reward for his study and perseverance than being able to settle down in some pleasant country benefice, dividing his time between preaching and poetry. Many of Cartwright's effusions found their way into print, and his ballad-story, *Armine and Elvira*, published in 1762, achieved such popularity that it ran through seven editions within little more than a twelvemonth. In an Essay on Imitations of the Ancient Ballad, prefixed to the third part of *The Minstrelsy of the Scottish Border*, Sir Walter Scott refers in complimentary terms to the piece, and adds, "I have a vision of having met this accomplished gentleman in my very early youth, and am the less likely to be mistaken, as he was the first living poet I recollect to have seen. His poem had the distinguished honour to be much admired by our celebrated philosopher, Dugald Stewart, who was wont to quote, with much pathos, the picture of resignation in the following stanza:—

"And while his eye to heaven he raised,
Its silent waters stole away."

Cartwright married a Doncaster lady in 1772, and not long afterwards was presented to the perpetual curacy of Brampton, in Derbyshire, which seven years later he exchanged for a better living at Goadby Marwood in Leicestershire. His promotion in the Church was by no means rapid. He was of too independent a spirit, and was too daring in the expression of unfashionable views to win the favour of those who otherwise might have helped him forward; but he did not complain; he wisely adapted himself to circumstances, preaching solid practical sermons to his parishioners on Sundays, and employing his week-day leisure in studying and practising medicine for the benefit of the villagers, farming his little glebe, and writing verses.

So the even tenor of his life proceeded until a visit to Matlock in 1784 suddenly opened up a new world to him, and changed him from the quiet, contented country parson to the sanguine, ambitious, restless projector. Dining in a public room, Cartwright became deeply interested in a conversation which was started on the subject of the remarkable inventions of Arkwright and others, and the consequent extension of manufactures in the neighbourhood and throughout the country. It was urged, however, by one gentleman that Arkwright's cotton-spinning machinery was not an unmixed blessing, seeing that we should soon be making more yarn than our weavers could work up,

with the result that it would have to be largely exported to the Continent, and might there be woven into cloth so cheaply as greatly to injure the English trade. At this point, Dr. Cartwright ventured the remark that the only remedy for such an evil would be to apply the power of machinery to the art of weaving as well as to that of spinning. The notion was set down as absurd ; some Manchester gentlemen, who were presumed to have special knowledge of the subject, being most emphatic in its condemnation, contending that such a contrivance was impossible, on account of the variety and intricacy of the movements in weaving. Against this Cartwright instanced the automaton chess-player, a curiosity then attracting much attention, and argued that a skilful application of mechanism could surmount every difficulty. They were not convinced, but he was ; and when he returned home he could think of nothing else. After much brooding, he bent all his energies to the task of constructing the model of a power-loom, working incessantly in his rough and awkward way for several months, but steadily improving step by step, until at last, in April 1785, he took out a patent for the first of all power-looms. It was a rude enough affair compared with the complex and beautiful machinery now used, but it was the germ of all that followed. Improvements were added and fresh patents taken out by him in 1786, 1787, 1790, and 1792.

The difficulties he encountered were many. The machine-makers to whom he entrusted the construction of the loom did not carry out their commission, being unwilling to consume their time in what they regarded as a fruitless pursuit; while the manufacturers whom his loom was intended to benefit bitterly opposed its introduction. But no amount of antagonism could divert him from his purpose. When he saw that it would be impossible to secure the co-operation of the trade, he resolved to enter into business himself, and, with that view abandoned his pleasant parsonage and its peaceful surroundings, endeared to him by many ties, and upon some property which had devolved upon him and his family at Doncaster, built a spinning and weaving factory, and threw himself manfully into the struggle which was only to close with his life. His machinery was at first worked by a bull, but after a time he set up a steam-engine. But what with his own want of experience and the obstruction to which he was exposed, his enterprise did not prove profitable. His pieces were wilfully damaged, his workmen were driven away, and his patent rights were invaded, involving him in costly lawsuits. Still he persevered, accepting no rebuff; and still he went on inventing, leaving his loom to struggle gradually into favour as its utility became recognised.

The next leading invention to which he turned



D.^r Edmund Cartwright

himself was the woolcombing machine, which was even more original in idea than the power-loom. In the case of the loom, there was already a machine in use capable of performing the operation of weaving—a machine which had been in use with little modification for thousands of years—but with the combing machine it was different. A complete machine had to be created, for between the simple act of combing wool by hand and that of combing it by machinery there was no intermediary stage, no gradation; it was a mechanical change for which there had been no preparation. It would have been interesting to have been able to trace the gradual evolution of the idea of this machine in the mind of the inventor, but there is little to be got at in this respect beyond the records of the patent office and a communication of his own to a scientific periodical of the day. The latter is of so much importance in its bearing on our subject that we cannot do less than quote the main portions of it.

“This machine is,” he wrote, “I believe, the first of the kind; at least all former attempts (if there have been any) must have proved abortive; no wool was ever known to have been combed any other way than by the slow and expensive process of hand labour. The magnitude of this invention, in respect of its object and its importance to the woollen manufactures,

may in some degree be estimated by the quantity of combing wool annually grown in this island, which, according to the most approved calculations, cannot be less than 300,000 or 400,000 packs, the average expense of combing which by hand may reasonably be laid at £800,000 or a million. That this calculation is not far from the truth, we need only recollect that the body of woolcombers is supposed to be nearly 50,000, among whom the alarm which the introduction of this machine has occasioned is well known. Upwards of forty petitions from various parts of the kingdom were presented to Parliament during the course of the present session for its suppression; and for this purpose a Bill was brought into the House of Commons by the friends of the petitioners, but it was rejected by a great majority; indeed, had the principle of the Bill been admitted there had been an end to all manufacturing improvements. But setting even this consideration aside, on other principles of policy it would have been inadmissible; even on the principle of humanity to the petitioners, the only ground upon which it could be defended, there is reason to believe it would not have been necessary, the introduction of new inventions or improvements, whatever may be their value, being in general so gradual as to affect those whose occupation they interfere with almost imperceptibly.

“ I obtained my first patent for this important invention on the 27th of April, 1790. In consequence of some additional improvements, I obtained a second patent on the 11th of December in the same year. But it was not until nearly two years afterwards that my machine was brought to its present state of simplicity and perfection, when I took out a third patent, dated May 15th, 1792.

“ The wool, if for particularly nice work, goes through three operations, otherwise two are sufficient. The first operation opens the wool, and makes it connect together in a rough sliver, but does not clear it. The clearing is performed by the second, and, if necessary, a third operation. A set of machinery, consisting of three machines, will require the attendance of an overlooker and ten children, and will comb a pack, or 240lbs., in twelve hours. As neither fire nor oil is necessary for machine-combing, the saving of those articles, even the fire alone, will, in general, pay the wages of the overlooker and children; so that the actual saving to the manufacturer is the *whole* of what the combing costs by the old imperfect mode of hand-combing.

“ Machine-combed wool is better, especially for machine-spinning, by at least 12 per cent., being all equally mixed, and the slivers uniform and of any required length. On the first introduction of this

machinery it was found, when not carefully attended, to produce a greater proportion of noil and pinion than good hand-combing, but in its present improved state it makes much less than any hand-combing whatever. The advantages of machine-combing arise not merely from the saving of expense; yarn spun from it has a decided superiority, especially for curious purposes, such as superfine hosiery, &c. At Messrs. Davison and Hawkesly's mill in the neighbourhood of Nottingham, where this machinery is made use of, yarn is spun of a quality which it was thought no mill-spinning could ever have arrived at. In justice, however, to the spirit and ingenuity of those gentlemen, it must be added, that their spinning machinery is supposed to be upon a very superior construction. Besides the above mill, my invention is already introduced into many others, and in all probability as trade revives on the restoration of peace, will be universally adopted."

Cartwright's original machine consisted of a cylinder armed with rows of teeth, which revolved in such a manner that its teeth might catch and clear out the wool contained in the teeth of the fixed and upright comb. His second machine, however, patented on the 27th April, 1790, superseded this imperfect method by the contrivance of a circular horizontal comb-table. Our engraving represents the main features of Cartwright's second patented invention as embodied in

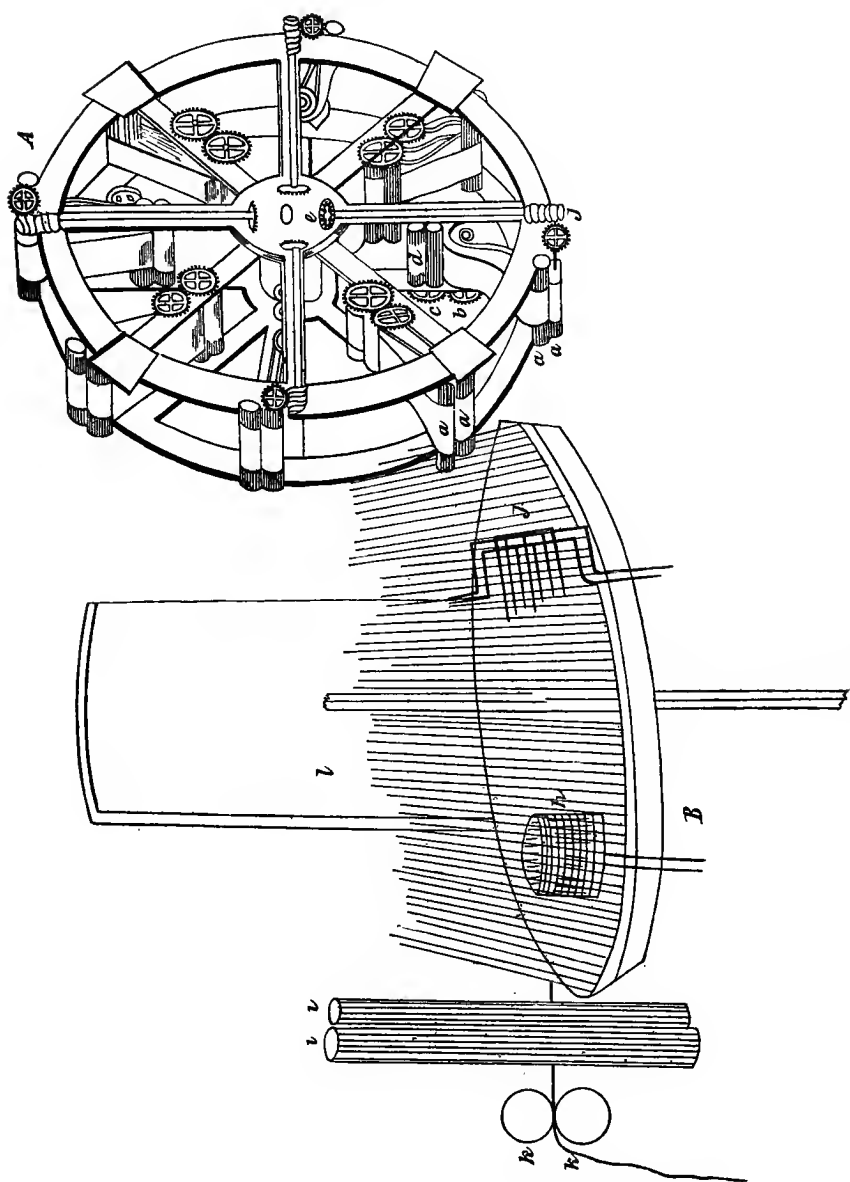

FIG. 3.—Dr. Cartwright's "Big Ben."

his Specification, and the following abridgement of his description will serve to explain the general principles of the mechanism of this early combing machine :—

A is the lashing frame, revolving with a quick motion ; *aa*, the delivery rollers ; *b*, the spole round which the wool is wound, having a wheel upon its axis ; *c*, a calendar roller, having a wheel upon its axis and receiving a motion from the wheel upon the axis of the spole ; *d*, the cloth roller held to the calendar roller by a spring ; *e*, a face wheel, receiving motion from a dead wheel fast upon a frame that supports the axis of the lashing frame, and within which the axis of the lashing frame revolves ; *f*, a shaft, the axis of the wheel *e* communicating by means of a worm or wheel with the delivering rollers. The spole is filled by the material to be combed, or heckled, being wound in at the front of the delivering rollers between two cloths, for which purpose the shaft *f*, and the wheel upon the calendar roller are thrown out of gear, and the rollers are turned by hand. *B* is the circular comb or heckle table, revolving with a slow motion towards the crank comb ; *g*, a comb working by a crank ; *h*, the smoothing pulley for laying the hairs in a straight direction ; *ii*, the drawing rollers ; *kk*, the conducting rollers ; *l*, the flue of stove which the teeth of the comb rub against for the purpose of keeping them hot. The spole, in

giving out the material, receives its motion from the delivering rollers by means of the cloths, which motion being communicated to the calendar roller, the calendar roller winds up the cloths as they are delivered out upon the cloth roller; and that the cloths may be always kept tight, the roller that receives them is constructed upon the principle of the common spring window-blinds.

The leading features of Cartwright's invention are—a principal comb, either circular or straight, and capable of a motion in a direction at right angles, or nearly so, to the direction of its own teeth; a second or clearing comb, either circular or straight, and capable of a similar motion, for clearing the wool lodged in the first-mentioned comb, which is called giving work in the head; rollers are also applied in the operation of filling the principal comb and drawing off the sliver, and cranks are applied in acts of lashing the wool into the principal comb and of working the clearing comb.

The principal comb is circular, its teeth point to its own centre, and it has a slow revolving motion round that centre.

To give the wool the first combing, and at the same time to feed or fill the principal comb with wool, the machine is furnished with a member or limb, called the crank lasher, the form of which is not without some resemblance to the human arm, to the action of which

the action of the crank lasher has still more resemblance. It has a joint corresponding to the human shoulder joint, a second answering to the joint at the human elbow, and at its lower extremity, it has a pair of rollers, with which, as with a hand, it takes hold of the prepared wool, draws it forward, and regulates the delivery, while, the lasher lashes it into the principal comb, the relative position of the crank lasher to the principal comb is of course regulated by the operation to be performed; as in like manner must its size be proportioned to the space through which the feeding rollers must pass in the operation of lashing, for the purpose of which operation a suitable motion is generated by means of a crank, the cross or crown bar of which passes through the lower branch of the lasher at some distance from its extremity; another distinct motion being also generated for governing protruding action of the feeding rollers by means of a wheel fast on the cross or crown bar of the crank; and in order to keep together and conduct to the rollers the prepared wool, a tube is attached to the lower branch of the lasher. For this first combing the wool is to be brought into a sliver-like state, and placed in a can or otherwise either behind or under the shoulder joint of the lasher, it is passed over that joint, then over the elbow joint, then through the tube, and entered between the feeding rollers, which of course

perpetually draw it over the lasher, and perpetually deliver it to the principal comb, as long as there is a supply of wool, and the machine is kept at work.

For the purpose of the latter combing, called giving work in the head, the clearing comb has a revolving motion in a plane at right angles, or nearly so, to the plane of the principal comb, so as that once in every revolution it strikes through the wool of that comb ; and for generating that revolving motion, cranks are again applied, a pair of them being used for this purpose. It is thought best that the teeth of the clearing comb should be inserted into the head or stock with obliquity, much in the manner of the teeth of the ordinary hand comb. For drawing off the sliver of combed wool, a pair of rollers is used, so placed that by the revolving motion of the principal comb, the wool with which it is filled is successively brought within the bite or grasp of these rollers ; and in aid of the first pair, additional rollers are also applied, to prevent lapping and improve the sliver ; and for conducting the sliver clear of the machine, conducting rollers are likewise applied.

Figs. 4 and 5 will serve to explain more fully. The former is a bird's-eye view of Cartwright's machine ; *A*, principal comb ; *B*, crank lashers ; *C*, clearing comb ; *D, D, D*, drawing-off rollers, with the assistant drawing-off rollers, of which there are a pair of each,

although three only are visible ; *E*, conducting rollers ; *F*, crank axis ; the prime mover giving motion to one lasher *a*, the axis of the crank carrying the other lasher *b b*, a pair of bevel wheels conveying the motion from

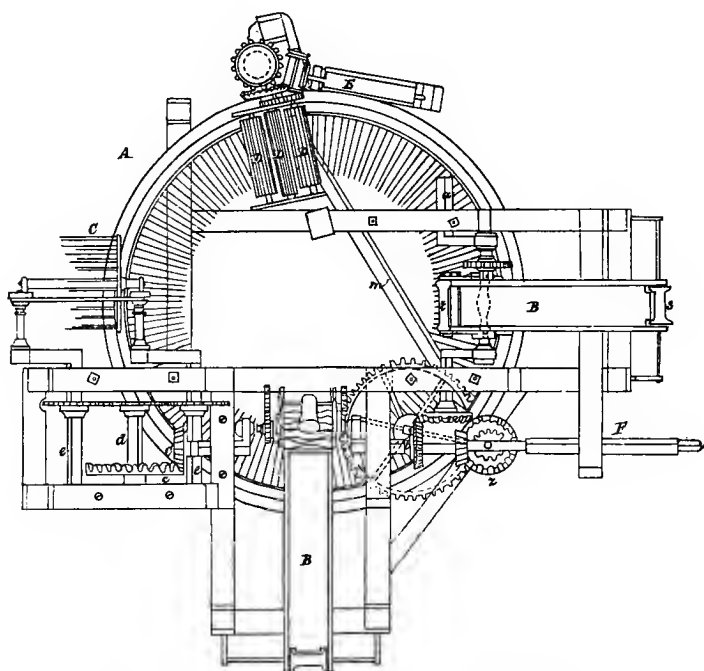

FIG. 4.—Bird's-eye view of Dr. Cartwright's Machine.

one lasher to the other, *c c*, another pair of bevel wheels conveying action to the axis *d*, upon which is a wheel giving motion to the wheels up *e e*, the axes of the cranks which carry the clearing comb, *f*, a bevel wheel upon one of the cranks, working in a bevel

wheel *z* on the axis of *g*; *h* a spun wheel working in *i*, another spun wheel upon the axis *k*, for conveying motion to the principal comb; *l l*, a pair of bevel wheels for giving motion to the axis *m*, and for generating action into the drawing-off rollers; *n n*, a pair of bevel wheels giving motion to the axis *o*, and for conveying action to the drawing-off rollers; *p*, a pinion on the axis *k* working into the wheel *q*; *q*, a wheel with inward teeth fastened to the rim of the principal comb, and by which the comb is carried round like the head of a windmill, this revolving motion being aided by trucks; *r r*, a pair of bevel wheels, one of which is upon the axis *o*, giving motion to the drawing-off rollers; *s*, the shoulder joint of the lasher; *t*, the elbow-joint of the lasher; *u*, a wheel fast upon the cross or crown bar of the crank moving the lasher; *v*, a wheel, on the opposite end of whose axis is a pinion working into a wheel on the axis of one of the delivering rollers; *w w*, the second roller, receiving motion from the first by a wheel, not visible in this drawing; *x*, the lasher tube already mentioned; *y y y*, &c., springs for pressing the respective rollers together. As soon as one revolution of the principal comb is completed, all the woolcombing operations are perpetually going on at the same time, each in its proper part of the circle, so long as the machine is kept at work, and wool is supplied, the principal comb continually carrying its empty teeth,

(cleared of the noils by hand) under the crank lashers to be filled, and the wool to be once combed, then carrying that wool under the clearing comb, to receive work in the head, carrying it thence to the rollers to be drawn off.

In the place of the original circular clearing comb is fixed a double socket capable of receiving two straight clearing combs, each of which can be swivelled into work or out of work at pleasure, and in an instant; while in work they stand with a certain degree of obliquity, which answers the same purpose as their former circular shape, of progressively entering the wool and combing deeper and deeper at every stroke. As soon as one of these straight clearing combs is sufficiently filled it is swivelled out of work, whereby the empty one is at the same time swivelled into work; the full one is then taken out of the socket, and a fresh empty one slotted into its place; the same operations are repeated as often as a clearing comb gets filled with wool.

Cartwright built great hopes on his woolcombing invention, and the novelty and ingenuity of the contrivance attracted no small attention. Indeed, it gave more promise of being remunerative than his powerloom, and several firms engaged in the worsted trade entered into negotiation with him with the idea of adopting the machine. So bright did the prospect

appear to the ever-sanguine inventor at this period that he indulged himself in giving an entertainment to his workpeople at Doncaster, on which occasion the wool-

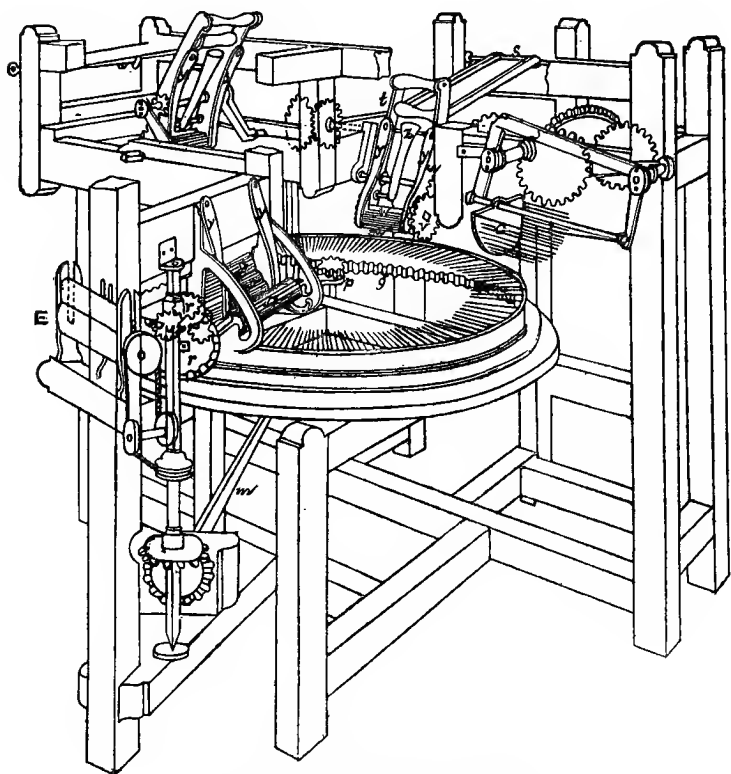

FIG. 5.—Dr. Cartwright's "Big Ben."

combing machine came in for especial honour. A procession was got up in commemoration of Bishop Blaize, the woolcomber's tutelary saint, and the streets of Doncaster were thronged with spectators intent

upon witnessing so unusual a spectacle. A song was composed for the celebration by one of the workmen named Mathew Charlton, and was set to music by Dr. Millar. Not only did this unique composition do duty at the feast referred to but it continued to be a popular ditty in the neighbourhood for some years afterwards. It is not a bad specimen of a song of labour, and deserves rescuing from oblivion if only for the sake of its pointed allusions to the woolcombing machine and its inventor. It ran as follows :—

THE NEW BISHOP BLAIZE.

COME all ye master combers, and hear of our Big Ben,
He'll comb more wool in one day than fifty of your men,
With their hand-combs and comb-pots, and such old-fashioned ways ;
There'll be no more occasion for old Bishop Blaize.

Big Ben was made at Doncaster, that place of great renown,
And is a noble fellow, supported by the Crown ;
Whenever you shall see him he'll put you in amaze,
And make you praise the inventor, our new Bishop Blaize.

Our triumph then this day there's nothing shall prevent,
For know, our great mechanic by Providence was sent
For the good of mankind, boys—a trophy then we'll raise
To our British Archimedes, our new Bishop Blaize.

The hungry he gives bread to ; the naked, too, he clothes ;
May health and joy and riches attend him as he goes ;
Then fill your glasses high, boys ! and give him three huzzas :
Here's our good and worthy master—our new Bishop Blaize !

It is necessary to explain that Cartwright's combing-machine was christened Big Ben after a celebrated prize-fighter of that day, the action of the crank-lasher suggesting the movements of a pugilist.

One of these machines was the first woolcombing machine introduced into Bradford, the adoption of it being due to the enterprise of Mr. Robert Ramsbotham, who set one to work in a room behind his house in Kirkgate. In a communication printed by Mr. John James in his *History of the Worsted Manufacture* mention is made of this. It is stated, "The machine, which was worked by a horse running in a gin, does not seem to have answered the expectations of its purchaser, for after working for some time it was taken down and sent away; indeed it would appear to have been a source of loss and annoyance, as the old gentleman is said to have taken off his hat to it as it left his yard; no doubt, at the same time expressing the charitable hope that 'Big Ben,' as it was called, might prove a better servant to its new master."

Great as was the merit of Cartwright's invention, it did not so completely fulfil its purpose as to be of immediate practical utility. It could be used with good results upon certain classes of wool, but failed in the manipulation of the finer qualities. For all that, the immense saving it was capable of effecting if

properly worked, caused its principle to be widely accepted, and in many instances the rights of the inventor were grievously infringed. Misfortune hemmed him closely in at this period. Messrs. Grimshaw, of Manchester, contracted for the use of four hundred of his looms, and a new mill was built to receive them, but they had not been many days at work when the factory was burnt to the ground. This was a terrible blow to Cartwright, whose private fortune had by this time become exhausted in his efforts to gain acceptance for his machines, and he was at length compelled to relinquish his works at Doncaster, where he assigned his property in trust for his creditors, and betook himself to London. Still he did not lose heart, but accepted the inevitable with philosophical resignation, and even wrote a manly and vigorous sonnet on the subject of his disasters. The lines have a true and honest ring :—

With sails expanding to the gales of hope,
My venturous bark pursued her leading star ;
Hers was a voyage of no common scope,
A voyage of discovery, distant far !
To bright Invention's intellectual clime,
In search of useful Arts, 'twas mine to roam :
I reached the object of my views sublime,
And richly freighted, bore my cargo home.
My friends expectant fill the crowded strand ;
But ere I gain the shore, what storms arise !

My vessel founders e'en in sight of land !
And now a wreck upon the beach she lies !
With firm, unshaken mind the wreck I see,
Nor think the doom of man should be reversed for me.

The value he set upon his woolcombing machine is evidenced in his reference to it in his memorial to the Society for the Encouragement of Arts, Manufactures, &c., when an unsuccessful candidate for the post of secretary to that body. "By that single invention of woolcombing," he wrote, "the manufacturers are at this moment saving at least 40,000*l.* a year, and in a short space of time will annually save between one and two millions." This was in 1798. In the following year his assignees were compelled to take action against a manufacturer who had notoriously infringed Cartwright's patent, and although they were in the first instance nonsuited on a point of law, they subsequently applied for and obtained a new trial, when after a laborious investigation extending over two days before Lord Chief Justice Eldon, a verdict was given in their favour, with a thousand pounds damages. Still the inventor failed to make money by his machine, and as his patent-right would expire in four years, it was determined to petition parliament for an extension of the term. Such a document was prepared and presented to the House of Commons on the 17th March, 1801. It represented that the labour of many anxious

years, fruitful in benefit to the public, had brought him no other reward than barren representation, "a situation bitterly aggravated by his having been obliged to behold many scandalous invasions of his property, without the means of resistance, and he might even have had taken from him the honour of having been the inventor of the art of combing long wool by machinery, had it not been for the assistance of friends, by whose means he was enabled to vindicate in a court of law the originality of that invention." The petitioner went on to explain in well-considered terms, his various personal losses in connection with his inventions, which losses he estimated altogether at 30,000*l.* and he urged that "seeing that the patents which included his woolcombing machine are respectively drawing near to their expiration, while yet the degree in which the machines have been adopted is far too small to flatter the patentee with even a hope of paying the interest on his debt, unless the legislature shall generously take him under its protection, he has resolved to make the present application for an extension of the patent terms, so far as relates to the combing and preparing of wool."

A committee of inquiry was appointed, and various witnesses were examined on the subject. One witness bore testimony that he had been employed for seven years in a mill where six sets of the combing machines

were used, and estimated the profits arising from each set at 1,100*l.* per annum. He also mentioned other mills where the combing machines were employed, and expressed the opinion that had it not been for the invasion of the patent, the original machine would have been in general use. Several petitions were presented in opposition by persons whose interest it was to defeat Cartwright's application, but ultimately the concession prayed for was granted, and it now seemed as if the inventor might with confidence look forward to a substantial reward for his long years of struggle. But he was again doomed to disappointment. The lack of pecuniary means still hindered him from asserting his rights when those rights were invaded, and he at last relinquished all hope of monetary reward from his invention, and it remains a melancholy truth that no advantage ever accrued to him in respect of this important invention. The fact that he engaged himself in other undertakings from which he looked for more immediate results doubtless helped to induce a certain apathy in his mind with regard to the combing machine; and after all, viewing the matter from a hard, practical standpoint, it has to be admitted that the machine, marvellous as it was as an effort of invention, did not accomplish all that was claimed for it, and that neither in Cartwright's time nor for many years afterwards was there a woolcombing machine in use which

succeeded in treating the fibre as effectually as it was capable of being treated by hand. Big Ben had made it clear that the problem could be solved, but it had not solved it; that was a work that remained for another generation of inventors to complete.

It is due to the memory of the inventor, however, that we should make a brief reference to the later incidents of his useful career. He never ceased inventing. When he settled down in London he set himself to the systematic pursuit of scientific discovery. "It was now too late," wrote his daughter, "to return to that peaceful mode of life, and those literary pursuits, in which he had passed the best and happiest of his years." His little house in Marylebone Fields became a very treasure-house of arts and sciences; nothing was too little and nothing too great to exercise his ingenuity upon. He made bread in his own kitchen by machinery; published a scheme for rendering houses fire-proof; invented bricks on a geometrical system; made a machine for biscuit-baking; helped Fulton with his first steam-ship models; brought chemistry to bear upon the science of agriculture; introduced a new three-furrow plough; got the Agricultural Board's gold medal for experiments in manure, and their silver medal for an essay on the culture of potatoes; and obtained patents for callendering linens, making ropes, and cutting velvet pile. Indeed it may

be said of him that he went to the grave inventing. Being sent to Dover, in his eightieth year, for warm sea-bathing, he invented a method by which the bathman saved the labour of two men in pumping up the water. A few weeks later he designed the model of a new Centaur carriage, as he styled it ; and a day or two previous to his death he wrote an elaborate argument to a friend on a plan he had discovered of working the steam-engine by gunpowder instead of steam. It is pleasant to reflect that the latter years of his life were passed free from embarrassment. His power-loom had been working itself gradually into favour with the manufacturers of the north, while his combing machine was just as gradually losing what little hold it may have got ; and it was in respect of the former invention that a memorial was got up and presented to Parliament, with the result that the Government granted Dr. Cartwright a sum of 10,000*l.* "for the good service he had rendered the public by his invention of weaving." The grant was made in 1809, when Cartwright was sixty-six years of age, and he lived until 1823, dying at Hastings on the 30th of Oct. of that year.

To the last he felt bitterly on the subject of the wrongs of inventors, but a letter written by him to Dr. Bardsley, of Manchester, not long before his death is worth quoting if only to show that he could at

all events take a humorous view of the situation. "A patent is a feeble protection," he wrote, "against the rapacity, piracy, and theft of too many of the manufacturing class. There is scarcely an instance, I believe, of a patent being granted for any invention of real value, against which attempts have not been made to overthrow or evade it. It might be supposed that whatever was confessedly original and which had never been heard or thought of before, would have some chance to escape the attacks of the invader. No such thing. Were that eminent surgeon and anatomist, Mr Carpue, who, it is said, has lately furnished some of his patients with supplemental noses, to discover a method of putting an additional pair of eyes into a man's head, and to take out a patent for the discovery, I should not be surprised if forty witnesses were to come forward to swear that it was not a new invention, for that they had seen forty people with forty extra pairs of eyes in their heads forty years ago."

Such was the man who with wonderful singleness of purpose and devotion dedicated his remarkable inventive genius to the improvement of his country's manufactures. His achievements are worthy of being recorded side by side with those of Hargreaves, Arkwright, and Crompton. The whole character of the man is indicated in the following happy lines,

forming part of a poem he wrote in his eightieth year :—

With mind unwearied still will I engage,
In spite of failing vigour and of age,
Nor quit the conflict till I quit the stage.

Several inventions in connection with woolcombing, in addition to those of Cartwright, were patented in the last decade of the eighteenth century. William Toplis, in 1793, obtained protection for a system of combs, with curved teeth fixed on arms, and combers which when in action turned in the direction of the combs. On the shaft of one comber was a wheel, which, by means of other wheels and a rod, gave motion to the second comber, or the motion was capable of being communicated to the latter by a train of spur wheels. There were rollers to which motion was given by, and which delivered wool to the combs. The wool to be combed was spread on a cloth rolled up or twisted into thick ropes, or made into long slivers. Either way, the wool had to be introduced between two rollers and passed behind a third, which had a broad flange to keep the wool from spreading out wider than the teeth of the combs, or it might pass between two rollers placed below the first-mentioned two, one of which might only bear against the other slightly, so as not to hold the wool fast. The teeth of the combs on the first comber passing through the wool

was brought down by these rollers took away a part, as it and the points of the combs of the second comber being made to meet the wool upon the combs of the first comber, as the respective combs passed each other, the necessary operation was performed by the comb teeth of the comb on the second comber working through the wool on the combs of the first comber to straighten the wool and draw such staples away as were too loosely connected with those combs. The curvature given to the teeth of either or both depended on the length of the wool, and might vary as circumstances required, and the number of the pitch of the comb might be more or less "as fancy might lead." The combs might be made broader or narrower, as more or less work was required to be done, and the combers might have any number of combs, as might be thought proper, varying the length and increasing the number of the arms of the combers. This ingenious contrivance did not obtain very wide acceptance, nor was Mr. Toplis encouraged to make any attempt to improve his machine.

In the same year (1793) we find for the first time the mention of the name of Mr. John Hawksley in connection with woolcombing inventions. Mr. Hawksley introduced many improvements in this process at one time and another, but his initial appearance at the patent office was in conjunction with Henry Wright, in

1793, in respect of machinery "for combing and preparing fibrous materials for spinning." This machine had an upright shaft revolving about forty times a minute. A wheel with thirty-two cogs gave motion to the comb-wheel, which had three rows of teeth on each arm. There was also a combing cylinder with three rows of teeth, which might be either horizontal or perpendicular. The wool was drawn from the cylinder by wheels, and there were rollers to conduct the combed fibre into a can or basket. The feeding frame comprised a fly with brushes and rollers, "to lay the wool close to the teeth of the cylinder"; a pair of blast bellows to convey hot air to the wool, and to assist in laying the wool; a circular brush to take the noils off the teeth, close to which was fixed a row of teeth to take the noils off the brush as it revolved.

Forming part of Wright and Hawksley's patent of 1793 was another combing machine, capable of being used as preparer or finisher, or both. It presented a straight range of combs in three compartments, and connected by a hook or catch at the top, moving in a slide or groove, and made to remove or take off after they had passed "the long cogged wheels, when they would have got quit of the wool." A rack which had a very slow sliding motion was moved by a pinion, two cogged wheels drew the wool from the comb teeth,

against which were placed two conducting rollers. The motion of the straight range of combs being slowly progressive, it followed that when these had advanced the length of one compartment, that part was taken away and discharged of its noils, and then passed to the other end of the machine on an inclined plane or otherwise, and fixed in the vacancy, and so on alternately, by which means a perpetual sliver of wool was produced.

In 1795, John Passman patented a special method of "opening the staple and bringing it into a proper state for lashing upon a comb"; and in the same year a combing machine of some importance was patented by Anthony Amatt, which properly carried out the idea of working the hand comb by mechanical means. Amatt claimed for his invention that it was "upon entire new principles for combing wool and heckling flax and hemp," and that it might be worked or used "by water, steam, or horse mills, or by any other moving power." The invention provided a separate machine for each of the three principal motions of filling, combing, and drawing-off. The material to be worked was spread in the shape of a sheet upon an endless feeding cloth, and slowly carried towards the feed rollers. Held by these, the projecting ends were combed and cleaned by middle combs, fixed upon a revolving shaft, and, as the feed rollers gradually

revolved and relieved the fibres, these were transferred to the comb, gradually becoming filled with fibres. The machine was then stopped, and the filled combs were taken off and replaced by empty ones. The combing of the filled combs then took place in the combing machine, the movements given to the comb being an imitation of the motions of the working comb in handcombing. The filled comb was firmly fixed into a bar which rose gradually during the working. The working comb was fastened to another bar, and received motion by means of connecting rods, and the crank from the revolving shaft. To cause this comb to penetrate properly into the fibres of the comb below, and thus to comb them as if by hand, the top end of the connecting rod was guided by frictious rollers. At the commencement of the working the filled comb was in its lowest position, so that the working comb could only comb the ends of the tuft of fibres. By a slow revolution of an eccentric, the lower comb was raised higher and higher, so that the teeth of the working comb penetrated gradually until, when the eccentric had completed its revolution, these teeth of the working comb penetrated as closely to the filled comb as was possible, when, as the combing was then finished, the eccentric stopped the machine, and the combs were removed and fresh ones put in. The drawing off apparatus consisted of a sliding frame, upon which

were fixed a revolving screw and a pair of drawing off rollers. The working comb was then fixed upon a plate, and placed in such a manner upon the frame that the movement of the screw would cause it to advance towards a pair of rollers, which took hold of the projecting end of the tuft of wool in the comb, which had been previously combed, and delivered it as a continual band and sliver into a can which was placed underneath. By thus drawing the other ends of the fibres through the teeth, this end was also cleaned, and only the noils remained in the working comb, which was then removed by hand.

Amatt's idea has largely engaged the attention of later inventors, and improvements upon it were successively effected by James Noble (1834) Donisthorpe and Rawson (1835 and 1840), Collier, &c., but although the improvements thus made brought the principle to the highest degree of perfection, these combing machines required such an amount of human attention, and tore and entangled the wool to such a degree, that in comparison with the capabilities of the newest and best machines the results were very unfavourable.

Mr. John Hawksley effected a further improvement in woolcombing in 1797. His patent of that year comprised a circular revolving comb-pot to heat the combs, a "lasher or layer on of wool" on the combing

machine, and "a socket or holster in which to place the combs in their respective compartments" in "a readier manner than theretofore used" for drawing off the wool from the machines.

This brings us to the end of the last century, at which point Cartwright's combing-machine, with the addition of certain other improvements (chiefly those of Hawksley), remained the one machine which indicated the lines whereon future success in mechanical woolcombing was to be obtained. Amatt's invention, as we have seen, also contained the germs of great improvement; but, in spite of all that had been accomplished, the worsted trade was still for many long years to rely upon the handcomber for the bulk of its woolcombing.

CHAPTER VI.

THE TRANSITION PERIOD.

THE transition from handcombing to machine-combing was a long, gradual, and interesting process. Three leading operations had to be performed—the filling, the combing, and the drawing off. Therefore, all combing-machines, of whatever principle or construction, must comprise (1), a feeding apparatus ; (2), a working comb ; and (3) a drawing-off movement. These were the three processes of handcombing, and no matter how intricate and complicated the mechanism may be of the inventions which have superseded the handcomber, these processes must have their counterpart in any machine that combs wool. In the early stages of machine-combing it was imagined that no mechanical contrivance was possible that could perform these operations as completely as they had been accomplished by the handcomber, but it is now evident that even the least effective of existing combing-machines can far surpass in its results the old handcombing

operations. Under the latter system, some descriptions of fibrous substances could not be made perfectly clean, even with two or three combings, and the "top" had to be carefully picked by hand before the final impurities could be removed. All machines therefore that have been restricted to the single operations of filling, combing, and drawing-off, as under the handcombing system, have been unable to overcome the deficiency of the latter. The top is not free from short hairs and knots, and requires to be combed twice before the yarn becomes sufficiently fine and even.

The older combing-machines laboured under the same defect as handcombing, but at the present time the only machines that are deserving of notice are those which produce a perfectly clean top. The great difficulty with which inventors had to contend was to attain as perfect a combing of the middle portion as of the ends of the fibre, and it took many years of thought and application before this was achieved. In all later machines there are now four principal processes—the three before named (feeding, combing of the fibre ends, and drawing off), and (4), the combing of the middle portion of the fibres by means of an intersecting comb.

The woolcombing machine as Cartwright left it was of little practical use. Still sufficient had been accomplished to inspire men of inventive genius with

the belief that a really efficient machine was capable of being evolved. So strong were some men in this conviction that they devoted their lives and energies with singular tenacity of purpose to working out the problem, and though success was slow in coming and involved repeated failures and a vast outlay of money, the work had to be done and was done. For the first forty years of this century the handcomber held the position of being able to produce better combings than any machine that had been invented, and indeed this class of operatives regarded with something akin to contempt the rivalry of machinery which was being set up, and were very confident in expressing the opinion that it was folly to imagine any machine could ever be produced that could comb wool equal to that combed by hand. The work of invention went on, however, in spite of these prophetic and not disinterested warnings.

In 1805, James Noble patented a machine for "discharging a wool comb or combs by separating the tear from the noils and drawing what was commonly called a sliver or slivers from the comb or combs, after or before the combs were worked or the wool was combed upon the same, and for other useful purposes." A component part of this machine was a travelling carriage or slide, moving backwards and forwards on rollers on the side rails of the frame. The motion was

regulated by a cord from a bevel pulley at the side of the frame. On the front of the carriage was fixed the comb, by means of a "staple and wedge." On the front of the frame was a pair of rollers, between which the ends of the comb of wool were placed, and as the carriage advanced the wool was drawn out in the form of a sliver, when the carriage returned to its first position. The drawn comb was then taken off the carriage and backed, and the noil taken off, and a fresh comb of wool ready for drawing placed on the carriage.

Six years later, Mr. George Gilpin took out a patent for a machine for combing and preparing wool. It appears that this machine had, mounted on a framework, four rings of iron, with six arms, each mounted upon iron spindles placed parallel to each other. Upon each ring four small standards were screwed to support the ends of wooden bars fixed parallel to each spindle, forming a frame to these bars, and to these were attached the combs. These wheels and bars were distinguished as the revolving comb frames, and the stationary and the sliding comb frame. The first had two motions, (1) a revolution with its axis, and (2) a transverse motion. The sliding frame had three motions, (1) like the stationary frame, it revolved on its axis; (2) its axis advanced to and receded from the other four times in every revolution; and (3) by this

movement all the machinery connected with the sliding comb frame was caused to advance slowly towards the stationary frame. These peculiarities of motion were caused by "elliptical cog wheels." "Stokers," consisting of short revolving arms, were placed over the combs for the purpose of returning the wool back to the points of the combs after it had been turned back to their heads by the combs striking each other. The machine was stopped in the proper position for changing the combs by means of levers and the agency of an attendant, the part of the mechanism for pointing out the time when the machine had made the proper number of strokes being of ingenious contrivance, being done by a count wheel fixed on a small spindle and bell.

We now arrive at the important development represented by the Collier machine.

In 1814 Mr. James Collier patented a woolcombing machine, in which he claimed "to prevent loss and unnecessary labour upon a substance which has always been considered the staple produce of this country" by a "new theory" which he described as consisting in "separating each fibre of wool, &c., so as to make them follow a direction parallel to each other, and by not holding or retaining them longer than is necessary to straighten the fibres, they slip through a number of points or teeth, so as to separate them from

each other without breaking or otherwise injuring them." He went on to explain that some sorts of wool required heat to retain the fibres in a parallel direction, and other sorts required both oil and heat,

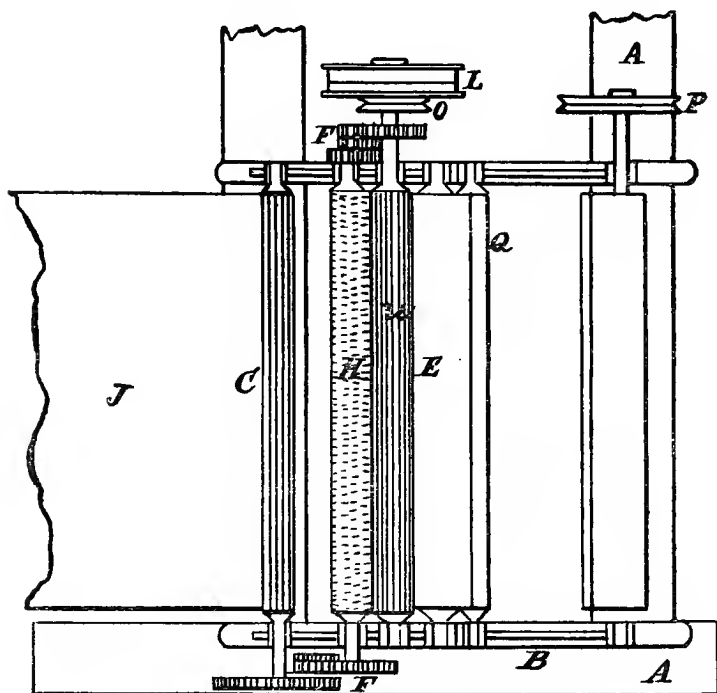

FIG. 6.—Bird's-eye View of Collier's Machine.

the first to soften, the latter to retain them; but, instead of employing coal, coke, or charcoal, he employed a small steam boiler to introduce steam into the inside of a taking-up roller, which was constructed of

metal and made hollow, for the purpose of receiving the steam, by which means the effect was obtained.

Collier's machine, the drawings of which are here reproduced, was thus described :—Fig. 6 is a bird's-eye view, Fig. 7 an elevation of the side, and Figs. 8 and 9 of the two sides. Fig. 10 is the combing roller.

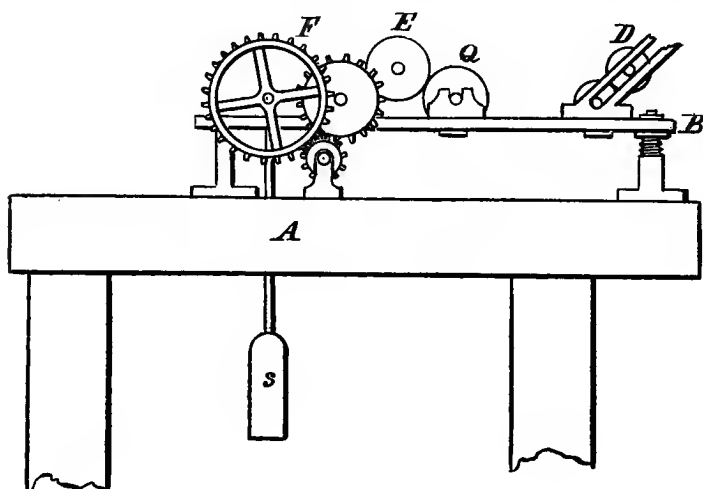

FIG. 7.—An Elevation of the Side.

“ The wool or substance intended to be combed having been previously beaten and cleaned, is spread as even as possible upon the plank J, Fig. 6, or else upon an endless cloth placed upon this plank. It is then brought forward between the iron-fluted rollers C, and conveyed over the combing roller H. Now as by means of the wheelwork the velocity of the three

rollers U, E, Q, which I denominate the clearing rollers, is greater than that of the rollers C and H, the wool, &c., is dragged through the teeth or points of the roller H and perfectly separated. The use of the rollers D is to receive the wool, &c., between them, and convey it from the clearing rollers U, E, Q, into a

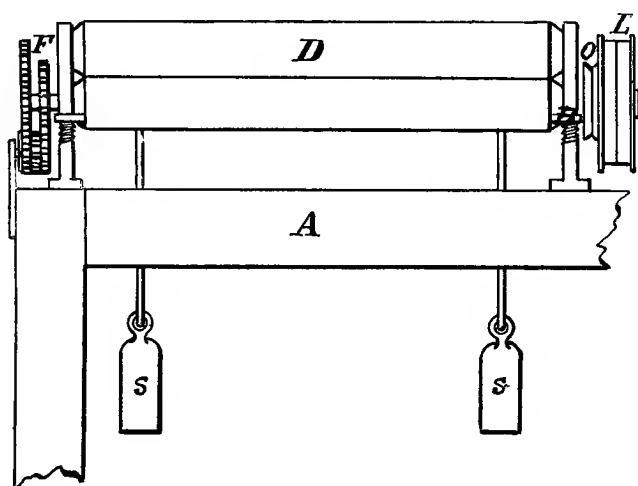

FIG. 8.—Elevation of the Side.

box, or on a bobbin, or round a drum, or to any other kind of receptacle as occasion may require. But, in order to clear the wool, &c., from the roller H, it is requisite that the teeth or points with which it is covered should press against the iron-fluted roller U, so that the spring of the teeth or points may force the

wool, &c., from this roller, in case it should catch. These several rollers are all weighted as at S, for the

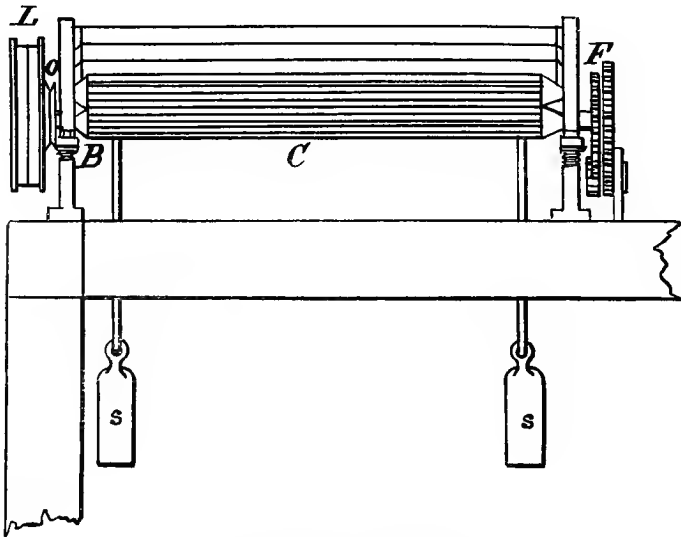

FIG. 9.—Elevation of the Side.

purpose of keeping them at their places and making them hold to each other, and are placed in sliding

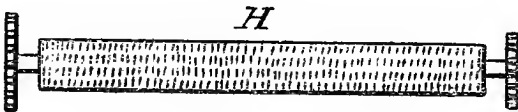

FIG. 10.—The Combing Roller.

supports B; their distances are regulated according to the wool, &c., intended to be combed.

The movement may be given to these rollers by means of a pulley L, a handle, or any other method of giving motion to machinery, and the communication from the pulley O to the pulley P is by a small cord or strap. The wheelwork F may be made to take off and put on simply by changing the wheels to vary the speed of the respective rollers according to the substance intended to be combed. A is the framework of the machine. The same letters of reference refer to the same parts of the machine in each figure.

The next woolcombing machine of any importance was an advance upon Collier's invention and was patented by Mr. John Platt of Salford, in 1827, and was known in the trade for many years as Platt and Collier's machine. The following description of this machine is taken from James's *History of the Worsted Manufacture*:—"This machine consists of two circles of combs, with a pair of drawing-off rollers attached to each circle. The two circles are placed at an angle to each other, as shown in the drawing and with the points of the teeth of each inclining towards the teeth of the other. The side elevation of the machine (Fig. 12) shows the 'top' as it is being drawn off. The raw wool is first filled into one of the circles at C by hand, the drawing having previously been thrown out of motion, and drawn a short distance back from the circles, so as to leave room for the mass of raw

wool which has been filled in to pass ; the two combs are then set in motion at a high speed in the direction of the arrows E E : one comb is filled all round with unwashed wool, and the other is empty. When they first begin to revolve they are so far apart that the points of the teeth in the empty comb barely touch the end of the fringe of raw wool hanging out from the



FIG. 11.—The Combs.

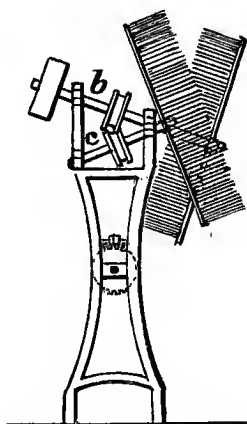

FIG. 11.—Enlarged Diagram.

other ; but by means of a screw and lever the two circles are caused to traverse slowly towards each other, till they reach the dotted lines D D, and come into the position which is called head and head. By this arrangement it will be seen that the empty comb works the wool hanging out from the other, and robs from it, at the same time gradually working deeper and robbing more freely, till when they come into the

position D D each comb is equally charged with worked wool, each having worked and drawn away from each other, the drawing rollers are moved up and connected

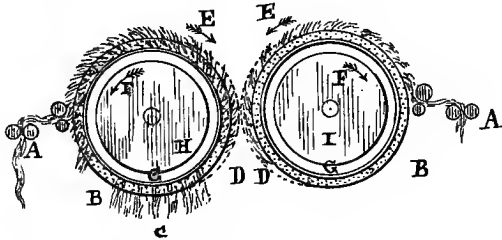

FIG. 12.—Side Elevation of Platt-Collier Machine.

with the circles at A A, and the 'top' is drawn off; the circles revolving slowly in the direction of the arrows F F, which is the reverse of their motion when working

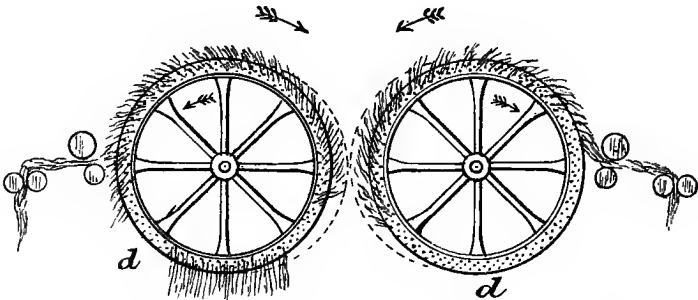

FIG. 12.—Enlarged Drawing of the Platt-Collier Machine.

the wool. The noil is slipped off by hand at B B. Both the circles are heated by steam."

Although the Platt and Collier machine represented a distinct advance upon the previous machines, it was

still insufficient to perform the operation of combing in such a manner as to satisfy the requirements of the trade. True, it was more largely used by spinners than had been the case with any previous machine, and on certain classes of wool was capable of being worked with fairly good results, but as compared with the combing of later machines, it produced a very large amount of noils, while it was impossible to obtain by it tops of a fine quality sufficiently clean for practical purposes. The cleansing of the fibre ends was only very partially accomplished, and the middle portion of the fibre was not combed at all.

There had been progress enough made, however, to encourage the hope that the perfect machine was at no distant date to become an actual realization ; thus it was that a new race of inventors were brought into the field, each devoting his skill and energy to the completion of the task which his predecessors had gradually brought within reasonable limits. The fundamental principles of the combing machine had been laid down originally by Cartwright. From the date of Cartwright's patent for fully half a century every inventor of woolcombing machinery had directed his efforts almost exclusively to the improvement of Cartwright's system, the leading features of which are still retained in some of the most successful machines of the present day.

About 1835 we first come upon the name of Mr. George Edmund Donisthorpe in connection with wool-combing. Mr. Donisthorpe was a native of Market Bosworth, where he was born in 1810. He early showed signs of inventive genius, and at the age of fifteen is said to have invented an improvement in the stocking-frame, which was at once adopted and became of considerable value. His abilities obtained the speedy recognition of his kinsmen, Messrs. Hitchcock, of Lichfield, with whom he entered into partnership; and in the year 1835 we find him associated with Mr. Henry Rawson, of Leicester, in certain improvements in wool-combing. In 1836 he left Leicester and took up his residence in Yorkshire, in the worsted district, in order to work the larger field that was there presented to him as an inventor. He now gave himself up completely to the work of making practicable the combing machine, and in 1840 took out a patent for further improvements. For two years thereafter he laboured incessantly at the machine, experimenting in secret, and obtaining a better insight into the mechanical difficulties of the problem than had been acquired by any previous inventor. Thus, in 1842, he was enabled to take out a patent for a combing machine of the Cartwright order in which many valuable improvements were for the first time introduced. The improvements consisted, to use the

language of the specification of patent, (1) in constructing combs with teeth set at a coarser gauge at the end where they first commence to work the wool, and of a finer gauge at the other end where the teeth were caused to penetrate the wool (under process) closer up to the head of the comb containing the wool ; (2) in combining working combs with combs which move in a circular or endless course ; (3) in an improved apparatus for filling combs with wool ; (4) in applying steam or hot water to the heads of combs, which were placed on a revolving axis where such combs had a movement to and from their axis of motion, in addition to their rotation round such axis ; (5) a method of using drawing-off rollers, each roller having an axis only at one end ; and (6) a mode of using two or more rotary combs with a moving, curved, or endless comb. Mr. Donisthorpe continued to employ himself actively upon the work of perfecting the machine with which his name had now become so closely identified ; and in the following year (1843) took out a patent for further improvements,—(1) in relation to apparatus for covering or holding down the wool or other fibres into a comb into which it was being fed during the time that the feeding apparatus was returning to feed another portion of wool or other fibrous material into the comb ; (2) in applying a blast of air to facilitate the raising of the wool or other

fibrous materials in combs when drawing off the same therefrom, and also to raise and direct the fibres of wool or other fibrous material into a suitable position for being taken hold of by the drawing rollers ; and (3) in reference to the combining rotatory combs, which worked on axes, and were governed in their movement by eccentrics or suitably-formed curved surfaces, with suitable means for causing a succession of straight combs to pass before such working combs, in order that the wool in such straight combs might be combed out, or worked by the rotatory combs. As regards the blast of heated air for heating the combs, the inventor explained that he had found the most convenient means to be the causing a blast of air to pass through a charcoal fire placed near the moving comb, and the products of heated air passed therefrom were diffused amongst the teeth of the combs and heated them.

It was Mr. Donisthorpe's woolcombing inventions of 1842 and 1843 that attracted the attention of Mr. S. C. Lister, and formed the incentive to the introduction of that gentleman to a sphere of industrial activity in which he was destined to achieve no little distinction. There is little doubt that Mr. Donisthorpe's was the master mind that first conceived in England the idea of a perfect combing machine—a machine, at all events, that was capable of performing

the operation of combing with a result equal to that attained by the laborious process of handcombing; and in the alliance that he formed with Mr. Lister he obtained an additional energy and an amount of practical ability and business capacity that greatly helped forward the joint enterprise. It is to be feared that Mr. Donisthorpe's individual fame as an inventor was somewhat overshadowed by the larger share of material success which attended the undertakings of those with whom he was associated, for although connected all his life with business schemes of importance he had not the keen business sagacity of Mr. Lister, and did not achieve the fortune that he otherwise might have done. He was too much engrossed in the work of invention to avail himself to the full of the benefits to be derived from that work.

CHAPTER VII.

THE DECLINE AND EXTINCTION OF THE HANDCOMBER.

BEFORE proceeding further with our narrative of the progress of machine-woolcombing invention, it is necessary we should refer to the attitude and condition of the handcomber in the face of the mechanical revolution which threatened his overthrow. During the eighteenth century the handcombers of England formed an important element of the industrial community, and were considered well paid and prosperous, according to the commercial estimate of the time. There were master woolcombers in those days, who bought wool from the staplers and gave it out to be combed by handcombers whom they employed. But gradually the master woolcomber disappeared from the scene as the spinners found themselves able to deal direct with the handcomber. In 1747, as is testified by the author of *The London Tradesmen*, these artisans earned from twelve to twenty-one shillings a week, and were the best paid

class of operatives engaged in the worsted manufacture. But even at that period, when mechanical invention had not yet thrown its shadow across their prospects, they were a discontented race, for ever combining against their employers and resorting to extreme methods of coercion and restriction. Discontent was the prevalent attitude of the operatives engaged in the wool industries for centuries. Even when spinning, combing, and weaving were among the cottage industries, and employers and employed were in more intimate association than in the days of the factory system, the relations between capital and labour were often of a strained character. Evidence of this is adduced from many sources, and is even demonstrated in the popular literature of the times, in which connection it is worth while quoting some labour rhymes of some two centuries ago, in which a most unfavourable picture is drawn of the masters of those days, and the sufferings of the workers. The verses, however, do not show that the woolcomber was in any worse plight than his brethren of the fleece generally, for although it was threatened to "bring them down from eight groats a score unto half-a-crown," it was to be the "Clothier's Delight" to bring them all to pretty much the same level. The following is the interesting and characteristic ballad referred to:—

THE CLOTHIER'S DELIGHT ;

OR, THE RICH MEN'S JOY, AND THE POOR MEN'S SORROW.

Wherein is exprest the craftiness and subtilty of Many Clothiers
in England, by beating down their Workmen's Wages.

Combers, Weavers, and Spinners, for little gains,
Doth earn their money, by taking of hard pains.

To ~~the~~ tune of—"Jenny, come tae me," &c., "Paddington's Pound," or
"Monk hath confounded," &c.

Of all sorts of callings that in England be,
There is none that liveth so gallant as we ;
Our trading maintains us as brave as a knight,
We live at our pleasure, and take our delight ;
We heapeth up riches and treasure great store,
Which we get by griping and grinding the poor.
And this is a way for to fill up our purse,
Although we do get it with many a curse.

Throughout the whole kingdom, in country and town,
There is no danger of our trade going down,
So long as the Comber can work with his comb,
And also the Weaver weave with his lomb ;
The Tucker and Spinner that spins all the year,
We will make them to earn their wages full dear.
And this is the way, &c.

In former ages we us'd to give,
So that our work-folks like farmers did live ;
But the times are altered, we will make them know
All we can for to bring them all under our bow ;
We will make to work hard for sixpence a day,
Though a shilling they deserve if they had their just pay.
And this is the way, &c.

And first for the Combers, we will bring them down
From eight goats a score unto half a crown.
If at all they murmur, and say 'tis too small,
We bid them choose whether they will work at all :
We'll make them believe that trading is bad ;
We care not a pin, though they are ne'er so sad.
And this is the way, &c.

We'll make the poor Weavers work at a low rate ;
We'll find fault where there's no fault, and so we will bate ;
If trading grows dead, we will presently show it ;
But if it grows good, they shall never know it ;
We'll tell them that cloth beyond sea will not go,
We care not whether we keep clothing or no.
And this is the way, &c.

Then next for the Spinners we shall ensue,
We'll make them spin three pound instead of two ;
When they bring home their work unto us, they complain,
And say that their wages will not them maintain ;
But if that an ounce of weight they do lack,
Then for to bate threepence we will not be slack.
And this is the way, &c.

But if it holds weight, then their wages they crave,
We have got no money, and what's that you'd have ?
We have bread and bacon and butter that's good,
With oatmeal and salt that is wholesome for food ;
We have soap and candles whereby to give light,
That you may work by them so long as you have light.
And this is the way, &c.

We will make the Tucker and Shereman understand
That they with their wages shall never buy land ;
Though heretofore they have been lofty and high
Yet now we will make them submit humbly ;

We will lighten their wages as low as may be,
We will keep them under in every degree.
And this is the way, &c.

When we go to market our workmen are glad ;
But when we come home, then we do look sad ;
We sit in the corner as if our hearts did ake ;
We tell them 'tis not a penny we can take ;
We plead poverty before we have need ;
And thus we do coax them most bravely indeed.
And this is the way, &c.

But if to an alehouse they customers be,
Then presently with the ale wife we agree ;
When we come to a reckoning, then we do crave
Twopence on a shilling, and that we will have.
By such cunning ways we our treasure do get,
For it is all fish that doth come to our net.
And this is the way, &c.

And thus we do gain all our wealth and estate,
By many poor men that work early and late ;
If it were not for those that do labour full hard,
We might go and hang ourselves without regard ;
The Combers, the Weavers, the Tuckers also,
With the Spinners that work for wages full low.

By these people's labour we fill up our purse, &c.

Then hey for the Clothing Trade, it goes on brave ;
We scorn for to toyl and moyl, nor yet to slave.
Our workmen do work hard, but we live at ease ;
We go when we will, and come when we please ;
We hoard up our bags of silver and gold ;
But conscience and charity with us are cold.

By poor people's labour, &c.

No woolcomber was permitted to take an apprentice except his eldest son, and they not only dictated their own rate of wages but sought to prescribe the prices which the masters should ask for the products of their labour. Such an arbitrary interference with the course of trade was naturally resented by the manufacturers, who bringing powerful influence to bear upon the government induced the legislature, in the twelfth year of the reign of George I, to pass an Act "to Prevent Unlawful Combinations of Workmen employed in Woollen Manufactures," which declared that all combinations "by any woolcomber or weaver, for regulating the said trade or wages, or lessening the hours of labour, were illegal and void, and that the persons entering into them, should, upon conviction, be liable to imprisonment not exceeding three months." Other enactments were also put into force to fortify the position of the masters, but in spite of all that could be done in this direction the woolcombers continued to band together in their own interests, and it is only fair to assume that they did not adopt such measures wholly without cause, for employers were far more despotic in those times than they are to-day, when, thanks mainly to the wiser and broader systems of protection which the operative classes have relied on, their welfare is as much guarded against wrong and injustice as the position of

the employers is secure from the tyrannical obtrusions of their workmen.

Still, with all their efforts at combination, frequent strikes, and constant agitation, their condition gradually yet surely deteriorated towards the close of the last century, and when Cartwright's "Big Ben" had to be counted with as an opposing force they were driven to petition Parliament against the introduction of woolcombing machines, and succeeded in getting a Bill brought into the House of Commons "for the purpose of protecting woolcombers from being injured in their manufacture by the use of certain machines lately introduced for the combing of wool." To counteract this a number of petitions were got up on behalf of the worsted manufacturers, setting forth the injury that would be done to an important industry if this Bill were allowed to become law, and the Worsted Committee for the counties of York, Lancaster, and Chester, sent a deputation to London specially to oppose the measure, the result being that the Bill failed to pass.

From this time forward the discontent of the woolcomber increased, although neither Cartwright's machine nor the improvements which Hawksley and others effected upon it operated seriously to his disadvantage. It was not until after 1840 that the woolcombing machine began really to threaten the

woolcomber with extinction, and even then few but those actually engaged upon or interested in the new machines believed that they would ever be able to comb certain classes of wool as effectively as they could be combed by hand. It was imagined that the machines laboured under some unsurmountable defect.

The decay of the handcomber was greatly accelerated by the events of 1825. In this year, which opened prosperously and was made memorable by one of the most elaborate Bishop Blaize celebrations of modern times in Bradford, there occurred the great strike of woolcombers and weavers which for several months paralyzed the worsted industry and left traces of disaster written largely upon the local history of that year.

Owing to the introduction of superior wools into the worsted trade, many changes had taken place in the conditions of woolcombing in the district, and the combers considered themselves entitled to certain concessions which the masters were not disposed to comply with. The disaffection spread to the weavers and the two classes of operatives ultimately combined, and on their demands being rejected by the masters they turned out and there commenced one of the bitterest struggles ever entered upon between employers and employed. Each week the breach seemed

to widen, and both sides kept up the contest with dogged obstinacy and endurance, the workpeople being determined to enforce an advance, and the masters being equally resolute in their determination to break down the protective organisation arrayed against them. It is estimated that when the strike was at its height there were not less than twenty to thirty thousand people out of employment. The chief demand of the combers was "for combing low sorts of wool, such as britch, and low warp and weft, an advance of a farthing, and a halfpenny per pound where fine wool was not combed, and a halfpenny per pound where the low sorts were broken out of the finer fleeces," which meant an advance of from two to three shillings a week. It was contended by the masters that they were paying higher prices than for combing than had been paid for many years previously. The attitude of the masters is shown in the fact that in the case of children employed at their works they dismissed all of them whose parents were in the Union, or who refused to sign a document declaring "that they had not joined the Union or any other society, nor would pay into any society to combine against their masters to raise wages." Very few, however, signed this declaration. From time to time the workpeople held meetings at Fairweather Green, near Bradford, at which speeches of a violent character were indulged in and resolutions

passed expressing the determination of the men not to return to their work until their demands were fully complied with. The masters on their part declared that the demands of the men were altogether unreasonable and not justified by the condition of trade, and sought through the intercession of Mr. Wortley, M.P. to obtain a re-enactment of the Combination Laws. That gentleman had an interview with Mr. Secretary Peel on the subject, but the Government refused to interfere further than to promise to bring forward a measure increasing the penalties for assaults and threats by Unionists against Non-Unionists. While performing this service for the masters, however, Mr. Wortley took occasion to ask the master manufacturers of Bradford to consider whether it would not be wiser, instead of refusing to listen to any proposals coming from a committee of the workmen and acting for them (however it might be constituted), to grant them at once every point which upon a full consideration might appear reasonable. But although the masters received the delegates of the workpeople and listened to their representations, it was impossible for any compromise to be arrived at, seeing that not one of the demands of the strikers was regarded by the masters as reasonable. The contest was most bitter. At one of the masters' meetings it was seriously proposed that all the mills should be stopped for three months, but the resolution

failed to pass by fifty votes to ten. When the strike had been in operation five weeks the workmen were so firm in the position they had taken up that they passed resolutions approving of the measures they had adopted and expressing themselves "much more than ever determined, whatever were the consequences, to abide by the resolutions" passed at former meetings. They acknowledged with gratitude the support which they had received from their fellow-workmen and the general public, and hoped that all parties would encourage them "for that they only wanted one thing and that they were resolved to have, which was, such a reward for their labour as they knew it richly deserved."

The extent of the contributions which the strikers received from outside sources may be gathered from the statement made at one of the meetings held about this time. "At the beginning of last week," it was said, "the committee were paying from 100*l.* to 150*l.* a day, but at the latter end of the week they were able to pay from 150*l.* to 200*l.* a day; and during the whole week they paid between 800*l.* and 900*l.* And notwithstanding this their stock of money that day was twice as large as on the preceding Monday. It was quite impossible to describe the zeal with which men came from every quarter to bring them money, all expressing admiration at their firmness, and exhorting them to persevere till they obtained complete success."

A correspondent writing from Bradford on the 27th July said that "many cartloads of children have been sent off to the neighbouring towns within the last fortnight." The same correspondent, commenting on the position of affairs at that time, wrote :—" If the masters were to make a statement of the prices they can afford and are willing to give, it would, I think, place them in a better position than they at present occupy in the general estimation, and would take away much of the reproach with which they have been assailed from their absolutely refusing any advance. That machinery to comb wool with will at some time be brought to succeed I have little doubt, but at present I do not think 'Big Bens' will compass the end. There is much to discover and much to be extended before these engines will supersede the use of animated machinery. In the meantime, while this contest lasts, the workmen must be suffering great privations, and the small capitalists must be verging towards embarrassment in their pecuniary relations."

Early in August misunderstandings arose among the masters, some of whom were accused of resorting to unfair practices. At this juncture Mr. Garnett conceded his men their demands and they returned to work ; but as regarded the rest, the strike continued much the same as before, a resolution passed by the workmen on strike during the following week setting

forth that the combers and weavers were still determined to continue in union, and that neither party would return to their employment even at the advanced price unless the advance should also be given to the other. In September the masters appealed for support to employers in neighbouring and even distant towns, and if they did not receive much in the way of pecuniary aid they were favoured with an abundance of sympathetic resolutions; while the woolcombers and weavers continued to receive increased funds from all parts of the country. In the same month a reduction of wages was made by the master spinners of Leeds as regarded their combing operatives, a step which the masters asserted was imposed upon them by necessity, and it was added significantly that the combing of wool half by machinery and half by hand was making rapid progress and threatened to place the operatives in a still worse state than they were then in. The Leeds combers, however, declined to accept the reductions, and thus a thousand more men were thrown on the Union.

When the Halifax masters passed a resolution similar to that which had previously been voted at Bradford, to compel their workpeople to sign a declaration that they were not connected with the Union, an address was issued by the operatives in the worsted trade, in which it was stated that they could not view

the conduct of the masters without surprise and indignation, and that it was no part of their duty to submit to such "unprincipled oppression." They added that "they were resolved not to be their absolute slaves, or to suffer themselves, their wives and children, to remain in the abject and degraded condition of irrational animals, but to enjoy that share of happiness and mental improvement designed for them by that gracious Providence which had placed them here as probationers for another and a better world."

A good deal of contention took place during this strike as to what had been the actual earnings of hand-combers in the worsted trade. At a meeting of operatives, John Tester, who had all through the strike acted as secretary to the Union and leading delegate of the combers, declared that the best workmen by working from 4 A.M. to 10 P.M. could earn only from 14s. to 16s. per week. In reply to this, however, it was said that for the six weeks previous to his turning out and becoming secretary to the Union, John Tester's wages averaged 1*l.* 4*s.* 1½*d.* per week, and that several others working the same description of wool earned more than that sum, working thirteen hours a day. A wool-comber writing to the *Leeds Intelligencer* affirmed that the combers had worked from twelve to sixteen hours a day and could not earn more than from 12*s.* to 14*s.* a week, and the answer to this was that the comb-shops

opened at five in the morning and closed about eight at night, and that even these short hours of labour were lessened by the fact that about an hour elapsed each day before the men commenced work and an hour a day was allowed for meals. No amount of argument of this kind, however, could alter the fact that, from whatsoever cause, the woolcombers were a hard-worked and poorly remunerated class. They were doubtless ill-advised and did themselves irreparable injury both in their present and future prospects in waging this long war with their employers. Quite apart from considerations of justice or injustice, it was to say the least impolitic on their part to make bad worse by their stubborn resistance. Right or wrong, the masters had might on their side, and against the united front which they presented to their work-people's demands it was impossible successfully to contend.

The first sign of collapse manifested by the strikers was on the 17th of October, when they passed a resolution declaring that "they would be very happy to meet their masters collectively for the purpose of ending if possible the unhappy dispute which had existed so long to the great prejudice and injury of both parties." But the masters were in no mood now for compromise. Nothing short of the most absolute submission would satisfy even the best disposed of them, and some refused to have any dealings whatever

with the operatives. Notices were issued by many of the masters in reply to the final appeal of the men, and this is how they ran:—"No advance—take combers at old prices." "No advance—do not want one half the hands." "None wanted." "Only want about half the hands." "Neither combers nor weavers wanted." "Do not want ten combers." "The combers had better turn in and do the work than let it be done by Big Ben."

The struggle was kept up for another week or two, but the resources of the Union began to fail, and nothing short of utter destitution stared the men in the face unless they could return to their work, and this at last they expressed themselves willing and anxious to do at the old wages of five months before. Thus ended the long strike, lasting over twenty-two weeks, and resulting in incalculable loss both to employers and employed. Over 1700 hands remained out of work when the masters had taken back all they could do with, and great distress continued to prevail. The loss in wages to the men during the period of the strike was not less than £40,000, towards which about half the sum was received in contributions to the Union. What the masters lost is beyond even computation. But, worse than all, the strike left traces of disaster and depression behind which were not effaced for many years.

The general trade eventually recovered itself, but the condition of the handcomber was never again to be what it had been. His occupation was doomed. In 1832 another strike of woolcombers took place, beginning at Dolphin Holme Mill, near Lancaster, and spreading to Bradford and Leeds. Although this strike was confined to the operatives belonging to one firm—Messrs. Hindes and Derham—over a thousand persons were thrown out of employment by it. This strike cost the Union £4000, and did not, any more than the great strike of 1825, advance the interests of the ill-fated woolcomber. Whenever a time of depression occurred, the combers suffered the most severely, and low as their wages had been they were still further reduced.

The year 1840 found the combers in a deplorable state of distress. Their spirit was now broken; they no longer had recourse to their old mode of expressing discontent by striking, but approached their masters with humble appeals, and instead of insisting upon the concession of specific demands gave vent to cries of wretchedness and despair. In July 1840 the Bradford Woolcombers' Association issued an address to the manufacturers of the town and neighbourhood. Even allowing for certain exaggerations of expression and sentiment which were natural enough under the circumstances, this document is one of the most touching expositions of industrial despondency ever put forth. It

affords in itself such a powerful picture of the sufferings of the woolcombers at that time that we cannot do less than quote the principal portions of it.

“Knowing the evil effects of turnouts,” it said, “we desire if possible to avoid them in future. We know that they can only be avoided by our masters uniting with us for the good of each ; and all angry feelings or animosities which exist in the bosoms of the employers or employed being banished and each other’s interests considered reciprocal. It must have been manifest to every master who has reduced the wages of his workmen, that previous to the reduction it was scarcely possible for any of his woolcombers to obtain an honest livelihood by their own hand labour. But now that the reduction has taken place our sufferings are augmented and our lives have become miserable. Our homes, which were not many years ago the abodes of comfort and domestic enjoyment, have now in consequence of the frequent reductions in our wages and other alterations in the sorts, become the dwelling-places of misery and receptacles of wretchedness. Our wives, who once were well clothed, comfortable, and happy, are now miserable and clothed in rags ; their spirits are nigh broken with repeated but ineffectual exertions to supply the necessary wants and requirements of our families. Our children, the pledges of our mutual love and conjugal affection, are squalid in their appearance,



HANDCOMBERS AT WORK.

with scarcely a rag to screen them from the bitter winter's blast, while the very small remuneration we receive for our labour will not permit us to make that provision for the development of their intellectual faculties which the growing state of their mental powers loudly demand. We feel assured that if you would ascend an eminence, and behold the emaciated frames, the pallid countenances, the ghastly aspects of the woolcombers when assembled together, you would acquiesce with us in saying that we ourselves are fast sinking into premature and untimely graves, the victims of broken spirits, protracted labour, and scanty fare. We are compelled to work from 14 to 16 hours per day, and with all this sweat and toil we are not able to procure sufficient of the necessaries of life wherewith to subsist on. When we leave off work at night our sensorial power is worn out with fatigue ; we have no energy left to exert in any useful object or domestic duty ; we are only fit for sleep or sensual indulgence, the only alternations our leisure knows ; we have no moral elasticity to enable us to resist the seductions of appetite or sloth ; no heart for regulating our households, superintending our family concerns, or enforcing economy in our domestic arrangements ; no power or capability to rise above our circumstances or better our condition ; we have no time to be wise, no leisure to be good ; we are sunken, debilitated, depressed, emas

culated, unnerved for effort ; incapable of virtue, unfit for anything which is calculated to be of any benefit to us at present or any future period. Therefore we entreat of you to unite with your workmen, with the philanthropic spirit which ever characterises the benevolent, the humane, the generous, and the good ; that you may obtain more profits, our wages become advanced, our hours of labour shortened.”

This strange, wild, and strained composition, though it struck many jarring notes, had hard, stern fact for its keynote. It was the wail of despair. It was heard with sorrow and pain, but it passed away without securing the response which those who framed it hoped it would have awakened. Such a combination as the address had suggested—of masters and men—could not have prevented the depression of trade ; nor could it have controlled the causes or prevented the consequences of that depression. The fact was the masters had had to contend for at least four years against constantly falling prices, and had for the most part been working at a loss during that period. The price of the raw material had declined 25 per cent., and of the finished fabric from $17\frac{1}{2}$ to 20 per cent. It was the inexorable law of supply and demand, not the want of sympathy of the masters that was responsible for the poverty-stricken condition of the woolcomber. Still, it was a deplorable state of affairs that did not admit of a

good workman, toiling from early morning to late at night—fourteen to sixteen hours—earning more than twelve shillings a week.

The Address of the woolcombers opened up a hot discussion, and the columns of the *Bradford Observer*, then the only newspaper published in the worsted metropolis, were largely made use of by the combers for ventilating their grievances, and by the masters for defending their own position. The line of argument taken up by the address was strongly emphasized by Mr. Henry Burnett, the Secretary of the Woolcombers' Association, in a letter which was published in the issue of the *Bradford Observer* for August 27, 1840.

“The reasons which caused us to write,” said Mr. Burnett, “were the reduction which had previously been made in the amount of our wages, and the alterations of our sorts, thereby making them considerably worse; the sympathy our masters professed to have for us when conversing with the deputations of their workmen, who waited upon them to ascertain the cause why they had reduced our scanty earnings; the declaring that the diminishing our wages was no benefit to them while it increased our privations and sufferings; the promise that each of them would advance what they had previously reduced if others would do likewise. We waited some time to

see if any of these professed philanthropists would set the very laudable example, but none of them have yet thought it consistent with philanthropic duties to do so."

Mr. Burnett proceeded to refer to the offer of the Address, "to unite for the protection of both," and then asked scornfully, "How has it been met? Why, by an additional worsening of the sorts, which has made us more miserable and wretched. What can be the object of our employers in thus treating us we know not; unless it is to make us more and more discontented, wretched and miserable, to reduce us to the lowest possible point of starvation—to goad us to madness and rebellion—compel us to leave our homes, and meet in one body, swearing by all that is virtuous and good that we will annihilate that power which is productive of so much misery amongst us. That this is their object we can but imagine, for there are none but will admit that riots and rebellions chiefly spring from discontent, and discontent arises from injustice, oppression, extortion, and distress. When men have to labour from fifteen to sixteen hours a day, and do not receive that remuneration for their labours which will secure them sufficient of the necessaries of life wherewith to subsist on, riots and rebellions may be looked for. . . . Men cannot tamely submit to see their wives clothed in rags and starving, their children crying for food and none to

give them. . . . We are men born for nobler purposes than to live slaves and submit through destitution to be hurried to premature graves. All we ask or desire is a fair day's wage for a fair day's work. . . . The conduct of the masters in not answering our address—the coldness and indifference manifested by them on our request for a Union, sufficiently evince that they have not one particle of sympathy in their composition ; that they are not possessed of any of the attributes that pertain to our common humanity ; and must have inflicted a wound that rankles in the breast of every woolcomber, and will never cease to remind him of the means whereby he is reduced to such a state of poverty, degradation, and misery. That we did not in our Address propose a remedy, it is true ; but our intentions were, when the Union was effected to endeavour to induce our masters to establish a Chamber of Commerce in Bradford, there to meet together and agree to pay an equal rate of wages, and sell the same as each other in the market ; and if any master was found not acting according to his agreement, but began to reduce the wages of his operatives and undersell the other manufacturers then those masters who considered themselves bound according to their agreement to protect themselves and the employed, should withdraw the workpeople employed by such unprincipled trader, and if possible employ them them-

selves, and we feel confident he would very soon be compelled to pay the same amount of wages, and sell the same as the market or give up trade."

It was natural enough that the ill-paid and wretched woolcombers should employ such arguments as these, and should regard the cutting down of their wages as an act of wanton cruelty. But the real truth was, the masters could not help themselves. It was not that they were indifferent to the sufferings of their work-people, but it was because they saw no chance of relieving them in the way indicated, that they made no advance to meet the woolcombers. Besides, it was argued on their side, the condition of the masters had not been that of ease and profit. They had been for the previous twelve or eighteen months on anything but a bed of roses; and trouble makes men selfish—that is, whilst it prevails—and men attend chiefly to their own sorrows. It was said, moreover, that if the Woolcombers' committee could inspect the balance sheets of the Bradford spinners in 1836, and compare them with those of 1840, they would see enough to convince them why wages had been depressed and why their masters did not meet their proposals, without imputing one and the other to the masters' selfishness and cruelty.

But the days of unity of action for the poor woolcombers were nearly gone; indeed, the days for

battling successfully against the tightening grasp of decay were gone completely. Their doom was sealed.

It was now that the woolcombing machine began to assert its power as a conquering force against the handcombers. Lister and Donisthorpe had entered the field of invention, and already improvements had been effected which rendered the machine available for work that neither Cartwright's nor Platt and Collier's machines had been equal to. Mr. Lister had sold machines as early as 1841 to Messrs. Wood and Walker (a firm employing a large number of hands) and for certain sorts they answered very well. But even yet the woolcomber refused to acknowledge the full meaning of this new power. Bad as his condition was, he clung to his miserable occupation with remarkable tenacity and would not see that as an industrial power he had not much longer to be reckoned with. "The machines may do well enough for certain sorts," they said, "but are of no use for others." Speaking at a meeting of woolcombers on strike in 1843, a comber said he wished Mr. Walker could put some of the sorts he gave to the men to the machines; that would show what they were worth. Still, in spite of all the excited opposition and agitation of the men, in spite of their eloquent and touching allusions to their "bitter pangs and blighting prospects," their position grew weaker and more

wretched day by day and in a corresponding degree the efficiency of the machine was strengthened and its use extended. Matters were now approaching a climax. In 1845 a Committee was appointed to inquire into the condition of the woolcombers of Bradford, and the report issued by that Committee disclosed a state of things even worse than had been revealed in the published statements of 1825 and 1840. It appeared that there were upwards of ten thousand handcombers in Bradford and the neighbourhood, the major part of whom were compelled to make workshops of their sleeping apartments and to live amidst the vapours of charcoal. Unable to pay the rent for a comfortable dwelling, a large number huddled together in one apartment, and this rendered their situation still worse.

After 1845 the woolcombers ceased to offer further resistance to the inevitable, and for their own advantage no less than the advancement of the worsted industry they were gradually superseded by improved machinery and were compelled to seek other fields of labour. They had, however, sunk so low that it was next to impossible for them to change for the worse. Many emigrated and sought fresh opportunities in new lands, but the greater portion of them connected themselves with other branches of the worsted manufacture, gaining for the most part not only increased remuneration for their labour but a far healthier mode of existence.

Cases of great individual suffering and hardship continued to occur, and no small proportion of the woolcombers and their families were compelled for a time to accept the refuge commonly accorded to paupers, or had to subsist on private charity, but the revolution that machinery effected in the work of handcombing was in its general results so beneficial to the community that even the handcombers themselves ultimately came to see that the change had been a gain all round. It took half a century to bring about this wonderful transformation, but after the display of woolcombing machinery at the Great Exhibition of 1851, when the latest achievements of both English and French inventors were shown, it was evident that the extinction of the handcombing industry was practically accomplished.

CHAPTER VIII.

THE BISHOP BLAIZE COMMEMORATIONS.

BEFORE finally turning to the distinctly modern phase of the history of woolcombing, as represented in the mechanical improvements of the past fifty years, and before taking leave entirely of the hand-combing period, we must not omit to pass in review those special industrial pageants which at septennial periods were held in honour of woolcombing.

Any history of woolcombing that failed to give some account of the trade festivals which have been held from time to time in honour of the patron saint of this industry would be open to the charge of incompleteness; we will therefore endeavour to recall the special circumstances connected with one or two of the leading Blaize celebrations, which have now become matters of commercial history.

The citizens of Bradford have erected a statue to the memory of the reputed founder of the woolcombing art—St. Blaize, or Blase, or Blasius. It stands at

the tower entrance to the Bradford Exchange, and serves in a measure to perpetuate the ancient legend which links the name of the bishop with an industry which has done so much for Bradford's fame and prosperity. Saints have not, as a rule, been much associated with trading pursuits, and there is probably not another instance of one of the exalted order even being connected by repute with the invention of important mechanical appliances. It is worthy of remark however that the first inventor of a machine for woolcombing belonged, like the inventor of the primitive hand comb which it was destined to supersede, to the Church, and though the Rev. Dr. Cartwright was but an ordinary clergyman and could not in point of sanctity compare with one who occupies the high position of saint, bishop, and martyr in the calendar of the Church of England, it is nevertheless a notable fact it was from the ranks of the priesthood that the woolcombing industry received its two principal creative spirits.

St. Blaize seems to have been a very exceptional kind of bishop, for he was famed in other ways than as the inventor of woolcombing. He was Bishop of Sebast, in Armenia, during the early part of the fourth century, and, according to Butler, was receiver of the relics of Eustratius, and executor of his last will. It is further related of St. Blaize that he lived in a cave,

whither wild beasts came daily to visit him, and be cured of him; "and if it happened that they came while he was at prayer, they did not interrupt him, but waited till he had ended, and never departed without his benediction." Bishop Blaize seems to have been more successful in his dealings with the members of the animal world even than St. Francis or St. Anthony, for the patron saint of the wool-combers, tradition has it, not only preached to and admonished the brute creation, but gave relief to their physical sufferings. Indeed, St. Blaize's power would appear to have been most beneficially exerted in administering to those who were afflicted by sickness or disease. Prayer was the only medicine he deemed it necessary to have recourse to, his appeal to heaven being regarded as more efficacious than all the physic in the world.

It is said that on one occasion, having been discovered in his retirement and cast into prison by his enemies, he cured by praying a youth who had a fish bone stuck in his throat, and thereby obtained release. It was for a long time a custom amongst the Greeks to invoke the spirit of St. Blaize in cases of affections of the throat. *Ætius*, an ancient Greek physician, it is stated by Ribadeneira, gave the following recipe for a stoppage in the throat:—"Hold the diseased party by the throat, and pronounce these

words—*Blaise the martyr and servant of Jesus Christ, commands thee to pass up or down.*”

Bland informs us that candles offered to St. Blaize were formerly said to be good for the toothache, and for diseased cattle :—

“ Then followeth good Sir Blaise, who doth
 a waxen Candell give,
 And holy water to his men,
 whereby they safely live.
 I divers barrels oft have seene,
 drawn out of water cleare,
 Through one small blessed bone
 of this same holy Martyr heare :
 And caryed thence to other townes
 and cities farre away.
 Each superstition doth require
 such earnest kinde of play.”

Another Blaize tradition is that a wolf having run away with a woman's swine, she prayed St. Blaize that she might have her swine again, and St. Blaize promised her, with a smile, she should, and the wolf brought the swine back ; then she slew it, and offered the head and the feet, with some bread and a candle, to St. Blaize. “ And he thanked God and ete thereof ; and he sayd to her, that every yere she sholde offre in his chirche a candell. And she dyd all her lyf, and she made moche grete prosperyte. And knowe

thou that to thee, and to all them that so shal do, shal well happen to them.”

Howsoever it may be as regards these matters, all chroniclers are agreed that Bishop Blaize was put to death by being tormented with iron combs, by the order of Licinius, in A.D. 316. This, some think, is the sole reason for Bishop Blaize having been adopted by the woolcombers as their patron saint. Others are of opinion that if he did not actually invent the art of woolcombing, he at least made considerable improvements in it.

Ribadeneira, whom we have previously quoted, gives a highly imaginative account of the martyr's death. He says, “St. Blaize was scourged, and seven holy women anointed themselves with his blood; whereupon their flesh was combed with iron combs, and their wounds ran nothing but milk, their flesh was whiter than snow, angels came visibly and healed their wounds as fast as they were made; and they were put into the fire, which would not consume them; wherefore they were ordered to be beheaded, and beheaded accordingly. Then St. Blaize was ordered to be drowned in the lake; but he walked on the water, sat down on it in the middle, and invited the infidels to a sitting; whereupon threescore and eight, who tried the experiment, were drowned, and St. Blaize walked back to be beheaded.”

It has been the custom from time immemorial to honour the memory of Bishop Blaize in this country. At one time it was usual on St. Blaize's Day to light fires on the hill tops or other conspicuous places. "So determinedly anxious were the country people," writes Mr. Robert Chambers in his *Book of Days*, "for the celebration by a blaze, that they would sacrifice articles of some importance to make one. Country women went about during the day in an idle, merry humour, making good cheer; and if they found a neighbour spinning, they thought themselves justified in making a conflagration of the distaff."

In more recent times however, and especially in the manufacturing districts of Yorkshire, the Bishop Blaize celebrations have been almost wholly restricted to the woolcombers' festivals. These have taken place in Bradford, Wakefield, Leeds, Halifax, and other towns of the West Riding, but Bradford has naturally claimed the right of taking the lead in the commemorative rejoicings, and during the early part of the present century, when hand woolcombers formed a large and important portion of the population, it was the custom to hold Bishop Blaize Festivals at septennial periods. The years 1811, 1818, and 1825 witnessed celebrations of a very imposing character.

There was a Bishop Blaize Festival in London on the 3rd March, 1730. It was the Queen's birthday,

and a procession of a hundred woolcombers marched through the principal streets to St. James's Palace. The men wore woollen caps, and "shirts over their clothes," and they had with them a person on horseback representing Bishop Blaize, who carried a woolcomb in one hand and a prayer-book in the other. He addressed the King and Queen, who appeared at the window, and thanked his Majesty for the encouragement they had so far received, and entreated his further protection.

The Bishop Blaize Festival which stands out prominently from all the rest is the Bradford celebration of 1825, when the town gave itself up with unstinted enthusiasm to the event. The year had opened prosperously, and on the 3rd of February, when the celebration took place, the commercial outlook was of a favourable and re-assuring character. The factories were all well employed. Indeed, for three or four years there had been a good trade, and the wool-combing community had not failed to participate in the general industrial success.

Thursday, the 3rd of February, 1825, found Bradford in full holiday aspect. The factories had shut off their steam, the machinery had been stilled to repose, the shops and smaller business places remained closed, flags and banners were flying everywhere, and the heavy cloud of smoke which the tall mill chimneys

usually sent forth—for there were no restrictions as to the consumption of smoke in those days—was absent for this one day. It might have been Sunday, the atmosphere was so pleasant, but there was too much din and commotion in the streets for any one to imagine that. The morning dawned brightly, and by an early hour the thoroughfares were crowded with people, visitors from neighbouring towns and villages having poured into the town in great numbers—some by coach, or other special conveyance, but most of them on foot. At this period, when railways had not yet revolutionized trade and traffic, when people were accustomed to work early and late, they made long days of pleasure as well as long days of labour, and were up and about betimes. Days of holiday-making and rejoicing were few and far between, so when they did come the people made the most of them.

On this particular Thursday morning the worsted legions thronged into Bradford from Bingley, Shipley, Horton, Thornton, Eccleshill, and more distant places—old and young, male and female—intent upon witnessing the great Bishop Blaize procession, the preparations for which had occupied their thoughts for many weeks previously.

The town looked very quaint and picturesque that morning, and had quite an old-world look in com-

parison with the massive newness which is its characteristic to-day. There was not a single public building in the town of any architectural pretensions, except perhaps the grimy old parish church which looked down from its eastern acclivity with much the same sturdy, stony stare that had characterized it in Tudor times, when the country people came to the Sunday market held in the churchyard, and in the exciting period of the Civil War, when the church was defended by the Parliamentary citizens against the besieging forces of the Royalists, the success of the defence being assured by the hanging of packs of wool round the edifice. On this particular February morning the bells in the steeple were kept merrily ringing, and bands of music were to be heard on all sides, for then, as now, Bradfordians were famous for their musical enthusiasm.

It is quite impossible to picture to the mind the appearance of the hilly town, where the worsted manufacture had become so firmly established and was so rapidly expanding, unless by the negative process of indicating such present prominent features as did not then exist. There was no Exchange, no Mechanics' Institute, no Town Hall, no theatre; the palatial warehouses, which now so effectually symbolize the solidity of the local industries, were not thought of; there were no commanding shops,

no spacious hotels, no market buildings worthy of the name, no streets that were not narrow and irregular. The Piece Hall was the only public structure in the town where any attempt was made to create a sort of trade gathering ground. Power-looms had not been introduced in Bradford as yet. It was not until the following year that the fatal riot took place at a mill owned by Messrs. Horsfall, on a number of looms being set up there. The period was, indeed, one of transition. Hand labour, with all its lethargic surroundings, was fast giving way to the advance of mechanical science. Old ideas and habits were being lost in the newer life, with its access of activity and its rich abundance of promise. As yet steam had not fully conquered the worsted realm, for there were still thousands of hand woolcombers employed in the district, and hand weaving was far from being supplanted. It was still the time of stage coaches and knee breeches, and gas had only just superseded oil-lamps in the streets. He whom flattery had designated "the First Gentleman in Europe" was on the throne of England, and Bradford had still some years to wait before it was to be permitted to send a representative to Parliament.

The public-houses were then an important feature of the daily life of Bradford. They formed the rallying ground for every description of gathering or

celebration, and the leading merchants, spinners, and manufacturers did not consider it beneath their dignity to frequent them. The Talbot was the great political rendezvous for the landed gentry and Tories, while smaller hostelrys, such as the Bull's Head and the Sun, obtained the patronage of the commercial classes. On this February morning of 1825 the crowd was greatest in the neighbourhood of the Bull's Head, for it was there that the organizers of the festival had arranged to meet, and there that the procession was to form and start.

Mr. Matthew Thompson, father of Mr. M. W. Thompson, the present Chairman of the Midland Railway Company, was the leading spirit of the movement, and was at the post of duty at the Bull's Head at an early hour of the morning. By eight o'clock the people who were to take part in the pageant had begun to assemble, and Mr. Thompson and Mr. Richard Fawcett, another prominent wool magnate, employed themselves with great energy in getting the processionists into their places. This was a work of considerable difficulty, and it was not until ten o'clock that the various sections were settled in the "order of their going."

One can easily imagine what a running fire of "chaff" the members of the procession would have to submit to during these preliminary marshallings

and orderings in character ; how ill at ease the weavers would be with their wool wigs, scarlet coats of stuff, red cockades, and coloured "slivers" of wool worn as sashes ; and how out of their element many of the woolsorters would feel at being on horseback probably for the first and only time in their lives. Then there would be the marching up of the various bands of music, playing some stirring old-fashioned air ; and when the distinguished personages who were "down" for the parts of the Bishop, King, Queen, Jason, and so forth, came upon the scene, the crowd would doubtless be with difficulty kept back.

The number of persons taking part in the procession was as follows :—24 woolstaplers, 38 spinners and manufacturers, 6 merchants, 56 apprentices and masters' sons, 160 woolsorters, 30 combmakers, 470 woolcombers, and 40 dyers. When the procession was ready to move off, Mr. Richard Fawcett, who was on horseback at the head of the spinners, advanced to the front, and, with head uncovered, delivered the following lines, which it had long been customary to repeat on these occasions :—

" Hail to the day, whose kind, auspicious rays
Deign'd first to smile on famous Bishop Blaize !
To the great author of our combing trade
This day's devoted, and due honour's paid ;
To him whose fame through Britain's isle resounds,
To him whose goodness to the poor abounds ;

Long shall his name in British annals shine,
And grateful ages offer at his shrine !
By this, our trade, are thousands daily fed,
By it supplied with means to earn their bread ;
In various forms our trade its work imparts
In different methods and by different arts ;
Preserves from starving indigents distress'd,
As combers, spinners, weavers, and the rest.
We boast no gems, or costly garments vain,
Borrowed from India or the coast of Spain ;
Our native soil with wool our trade supplies,
While foreign countries envy us the prize.
No foreign broil our common good annoys,
Our country's product all our art employs ;
Our fleecy flocks abound in every vale,
Our bleating lambs proclaim the joyful tale.
So let not Spain with us pretend to vie,
Nor India's wealth attempt to soar so high ;
Nor Jason pride him in his Colchian spoil
By hardships gain'd and enterprising toil :
Since Britons all with ease attain the prize,
And every hill resounds with joyful cries.
To celebrate our founder's great renown
Our shepherd and our shepherdess we crown ;
For England's commerce, and for George's sway,
Each loyal subject give a loud Huzza ! Huzza !”

The name of the author of these now historic lines has not been handed down to us, which is rather unfortunate, his couplets being secure of a more lasting fame than the verses of some who count for something in the world of letters. Mr. Fawcett read the piece with due emphasis and spirit, and at

the conclusion a round of ringing cheers arose, and the procession moved off in the following order:—

Herald bearing a flag.

Woolstaplers on horseback, each caparisoned with a fleece.

Worsted spinners and manufacturers on horseback, in white stuff waistcoats, with each a sliver over the shoulder, and a white stuff sash; the horses' necks covered with nets made of thick yarn.

Merchants on horseback, with coloured sashes.

Three Guards. Masters' Colours. Three Guards.

Apprentices and masters' sons on horseback, with ornamented caps, scarlet stuff coats, white stuff waistcoats, and blue pantaloons.

Bradford and Keighley Bands.

Macebearer on foot.

Six Guards. KING, QUEEN. Six Guards.

Guards. JASON, PRINCESS MEDEA. Guards.

Bishop's Chaplain.

BISHOP BLAIZE.

Shepherd and Shepherdess.

Shepherd Swains.

Wool-sorters on horseback, with ornamented caps,
and various coloured slivers.

Combmakers.

Charcoal Burners.

Combers' Colours.

Band.

Woolcombers, with wool wigs, &c.

Band.

Dyers, with red cockades, blue aprons, and crossed
slivers of red and blue.

The appearance of these festive personages was highly picturesque and imposing, and the crowds greeted them with genuine enthusiasm as they passed along. An old man named William Clough, of Darlington, impersonated the King, which regal function he had filled on four previous occasions. Jason, the mythological hero of the Golden Fleece, was assumed by one John Smith; and another individual of the same homely cognomen, who was described as "a personage of very becoming gravity," appeared in the important rôle of Bishop Blaize, he also having enjoyed his high ecclesiastical office at several former

celebrations. What damsel embodied the character of the fair Medea, the chroniclers of the period have not deigned to leave on record.

We are informed that "the ornaments of the spinners and manufacturers had a neat and even elegant appearance, from the delicate and glossy whiteness of the finely-combed wool which they wore. The apprentices and masters' sons, however, formed the most showy part of the procession, their caps being richly adorned with ostrich feathers, flowers, and knots of various coloured yarn, and their stuff garments being of the gayest colours; some of these dresses were very costly, from the profusion of their decorations. The shepherd, shepherdess, and swains were attired in light green. The woolsorters, from their number and the height of their plumes of feathers, which were for the most part of different colours, and formed in the shape of *fleur-de-lis*, had a dashing appearance. The combmakers carried before them the instruments here so much celebrated, raised on standards, together with golden fleeces, rams' heads with gilded horns, and other emblems. The combers looked both neat and comfortable in their flowing wigs of well-combed wool; and the garb of the dyers was quite professional. Several well-painted flags were displayed, one of which represented on one side the venerable Bishop in full robes, and on the

other a shepherd and shepherdess under a tree. Another had a painting of Medea giving up the golden fleece to Jason; a third had a portrait of the King; and a fourth appeared to belong to some association in the trade."

The procession moved slowly forward through the principal streets, making occasional stoppages in front of prominent business places and before the houses of some of the leading inhabitants. It was at one of these coigns of vantage that M. W. Thompson (then a boy of five) was put forward to recite the lines which had been previously spoken by Mr. Fawcett. Forty-three years after the event—in February, 1868—Mr. Thompson, then M.P. for Bradford, referred to the circumstance at a dinner given by the Bradford Overlookers. "My father thought it right," he said, "that I should take part in the procession, and he had me up every morning at breakfast until he had drilled into me a certain number of verses. I was put on the top of a door or out of a window at the bottom of Kirkgate, and spouted those verses to an immense number of people, although I dare say nobody heard me three or four yards off. I was then taken on a pony down into the Holme, and spouted the same verses to a number of workmen assembled round a table." Young Thompson, mounted on a fine Shetland pony, was

indeed one of the most interesting features of the procession.

At one o'clock the gay cavalcade reached the part of the town called the Holme, where factories and waste spaces alternated. The processionists were marched into a field facing Mr. Fawcett's factory, and there were regaled with sandwiches and ale, of which they partook freely—in some instances, indeed, too freely, it was afterwards confessed. Two hours were spent over this simple repast, the company being also treated to a fresh recital of the Bishop Blaize verses by young Thompson, the pet of the day, and to sundry congratulatory speeches. At three o'clock the procession set out once more, visiting parts of the town not previously covered by it, and finally, at the hour of five, arriving at the termination of its lengthy and exhaustive pilgrimage by being dispersed in front of the Sun Inn. The procession was half a mile in length, and must have formed an exceedingly picturesque sight, winding up and down the tortuous streets, and being followed along its whole route by an immense concourse of people. The most trying experiences to which the processionists were subjected were entailed by the frequent halts that were made in order that the inevitable verses should be given forth, Mr. George Thompson Lister, a local auctioneer of portly presence, and Mr.

John Rand, a popular spinner, taking turn with the juvenile Thompson and Mr. Richard Fawcett in the recital of them.

A few showers of hail and snow had fallen at intervals during the day, but they were of short duration, and being succeeded by gleams of bright sunshine were soon forgotten. After the procession broke up, the streets gradually became quieter, the country people hurrying off to their homes, leaving only the townfolk to carry forward the festivities. In the evening further rejoicings were indulged in by the masters, masters' sons, apprentices, &c.; the spinners, manufacturers, and merchants dining together in the large room of the then Court House, and the apprentices and masters' sons being similarly entertained at the Sun Inn. The dinner at the Court House was a very sumptuous affair. Nearly a hundred gentlemen sat down, Mr. Matthew Thompson presiding. The proceedings throughout were characterised by much enthusiasm, and most of those who spoke to the various toasts made allusion to the great prosperity then enjoyed in the wool trade. Mr. Thompson, upon whom devolved the important duty of proposing "The Immortal Memory of Bishop Blaize," waxed eloquent upon the fact that "ingenuity and invention were then put upon the rack to know how labour could be abridged, and what could be

done by machinery to supply its place. Unexampled were the exertions then being made by the silk and short wool manufacturers ; and as to the iron, so great was the demand that the furnaces appeared to make one general illumination from Carron to the Land's End. Whilst he was attempting round that convivial board," he said, "to describe the national prosperity, the senators of the land were at that moment assembled to tell them, and he did not doubt that they would be told by his Majesty's speech delivered that day, that the country never enjoyed so great a degree of prosperity in agriculture, manufactures, and commerce. He had no doubt that our manufactures would be very greatly extended, and that the continuance of peace, which opened fresh channels to commerce, and conveyed to savage nations the arts of civilised life, would in a few years cause our ships to visit every country and every port in the world, would impart new energies to our trade, and diffuse cheerfulness and content all around us." Reading these words in the light of events which so quickly followed—events that plunged the entire wool industry into the deepest distress—the marvel is that not one of the speakers at that gathering seemed to detect the coming shadow that for many of them doubtless meant ruin. But, as we show in another chapter, before the year had advanced to

summer, there were 20,000 workpeople out on strike in Bradford, trade was brought to a standstill, and the happy, contented community which Mr. Thompson had pictured so forcibly were reduced to destitution.

After 1825 there were no more great festivals held to celebrate the anniversary of St. Blaize. A feeble attempt was made in 1832 to awaken something of the old enthusiasm, but by this time the woolcombing fraternity had fallen so far from their ancient position of prosperity and honour that the holding of any festival in their behalf would have been resented as a mockery and an insult. The proposal was therefore allowed to fall through from sheer inanition, the end of it all being humorously notified to the public by the putting forth of a number of posters on the walls and hoardings of the town to the following effect :—

BISHOP BLAIZE.

Whereas, a number of evil-disposed persons lately assembled, and wilfully and maliciously

BURKED

The Venerable and Reverend Father in God,

BISHOP BLAIZE,

It has been determined by a number of his Friends,

out of Respect to his Memory, to give his *Remains* public and honourable *Burial*, on the *Third day of February next*. The Band and

FUNERAL

Procession to meet at the *Piece Hall Gates* precisely at Ten o'clock in the Forenoon, and it is requested that as many as possible who gain their *Livelihood* by the exercise of his Invention, will, out of gratitude to the Founder of the Trade of Bradford, follow his Remains to the grave.

☞ A Committee is appointed to receive contributions to defray the expenses.

The Committee Room, Talbot Inn, January, 1832.

With this imaginary burial was the end of the famous Bishop Blaize Festivals, although for many years afterwards it was the custom for persons engaged in the worsted trade to meet on the day of St. Blaize and dine together; but beyond this no attempt was made to revive the Blaize procession, until, on the occasion of the opening of the Bradford Town Hall, in September, 1873, when the boy, who in 1825 had cut such a prominent figure as the reciter of the Bishop Blaize ode, had come to be mayor of the town, a procession was organised that far outvied in splendour and costliness the pageants of 1825 and

former years. Although the procession of 1873 was rather a gathering of trade guilds than a Bishop Blaize commemoration, still the woolstaplers, master woolcombers (proprietors of woolcombing machinery), spinners, and others engaged in the worsted industry, combined in a special display on the ancient lines, and this formed the principal feature of the procession.

A contingent of woolstaplers, headed by a brass band, led the way, accompanied by a flag bearing the motto, "The Wool Trade." On the heels of these followed a gaily-decorated waggon, upon which a real woollorter was seen at work at a real sorting-board. The front of the waggon held a carved representation in wood of the legend of the Golden Fleece, the same that had been used in the celebration of 1825. A body of manufacturers on horseback and in carriages came next, and these were succeeded by eight large wherries, loaded with every description of wools—English, foreign, and colonial—over thirty different classes being represented, each class being indicated by the flag of the country where the wool was grown; some sixty or seventy woollorters, attired in the check pinafores peculiar to their order, with flags and banners profusely distributed amongst them, followed. The most prominent feature of the procession however was supplied by the combined

efforts of the combers, spinners, and manufacturers, and consisted of a collection of trophies of an ingenious and striking description. Foremost in this section was the Bishop Blaize trophy, drawn by six horses, each led by a groom dressed in the garb of a "beef-eater." The front of the waggon was arranged to represent a bower of lilies, enshrining an old spinning-wheel, emblematical of the origin of this branch of manufacture. Seated on a richly-draped dais in the centre of the vehicle was the representative of the famous Bishop, with sacred robes and crosier; and behind this figure two handcombers were hard at work at a couple of "pad-posts," combing wool according to the ancient method. There was also a man in the act of shearing a sheep; indeed, on this one waggon were shown all the stages of wool manipulation, from the time of its being cut from the back of the sheep to the period when it is ready for the spinning-frame. A large orange and blue flag bearing the inscription, "Hail, Bishop Blaize, our patron saint!" was carried in front of this waggon. Then there came a band, and about fifty employers on horseback and in carriages. These were followed by the representatives of the woolcombing interests—a very different body from that which had taken part in the gathering of 1825—comprising some well-known members of machine-combing firms, and a model of a Noble comb. Samples of machine-combed wool, tastefully

arranged on a waggon, came next. Then there was a large car, supporting a vessel representing the *Argo*, in which were figures representing Jason and Medea, the emblem of the Golden Fleece floating in the breeze above their heads. After these came the sizers, then the dyers, then the merchants, the latter having a trophy representing Britannia, with the traditional trident, sitting on a granite rock, with the globe under her feet. From this point the procession gradually lost its distinctive trade aspect, and became decidedly miscellaneous, but, regarded as a whole, the display eclipsed all previous industrial pageants connected with the worsted manufacture, and, as illustrating the contrast between the days when the handcomber was of consequence and influence in the district and the time when his extinction had been brought about by the progress of invention, was not without its instructive element. The presence of the combing-machine sufficiently symbolized the transformation which had been effected. The term "woolcomber" had completely changed its significance. In 1825 it indicated a member of the operative classes; in 1873 it was only used in regard to a class of employers. Bishop Blaize might well lose his hold upon the woolcombing community. To associate his memory with so modern a piece of work as the combing machine would have been little less than sacrilege.

CHAPTER IX.

JOSUÉ HEILMANN.

IN resuming our account of the inventive efforts which led to the ultimate solution of the machine wool-combing problem, it is necessary that we should say something of the remarkable efforts that were put forth by Josué Heilmann contemporaneously with the efforts of Mr. Donisthorpe and Mr. Lister. The part played by Heilmann in the development of woolcombing machinery was such a distinguished one that some reference to his general career as well as to his woolcombing inventions will naturally be looked for in a work of this nature.

Heilmann was born in 1796 at Mulhouse, in Alsace, where his father carried on the business of a calico printer. In his early youth Josué manifested a decided taste for the manual and mechanical arts, and often surprised his playmates by the ingenious contrivances he invented for their common amusement. He quitted the paternal roof for the first time in 1809,

for the purpose of entering the Pestalozzi Institute at Yverdun, a change which was little to his mind, since it prevented him following the mechanical studies upon which he had set his heart. The fact was, his father at that time destined him for the career of a merchant. It is related that during one of his excursions in Switzerland he one day heard a professor tell his pupils that they would never accomplish great things if they were always asking how much would be given to them in return. These words struck deep into his young imagination, and he made them the motto of his life.

Heilmann left Yverdun at the age of fifteen, and forthwith began his apprenticeship in his father's works, where he worked zealously and diligently, occupying his leisure moments in making drawings of machines. After two years of steady application the scene of his commercial studies was changed to Paris, to which place he removed in 1813 to take up a position in the banking-house of his uncle, and while fulfilling his duties as clerk he applied himself to the study of mathematics. In 1815 he returned to Mulhouse and received the appointment of cashier and book-keeper to his father, from which time he had the satisfaction of being able to support himself. In the following year his father decided to establish a little spinning concern, taking advantage

of the wave of industrial development which was then spreading over Alsace. This circumstance enabled Josué to give free play to his aspirations, and, with the view of affording him still further opportunities of acquiring a knowledge of the special business upon which he had embarked, his uncle the banker procured him a year's experience in the concern of MM. Tissot & Rey, at Paris, who were largely engaged in spinning. "It was then that I felt," wrote Heilmann, "suddenly placed in my own proper sphere. During this year of sojourn in the capital (1816) I devoted myself with profound seriousness, and with unremitting ardour, to my new career." He became a student of the Conservatoire des Arts et Métiers, where he followed a special course of physics, took almost daily lessons with a machine-maker, and passed his Thursdays in studying the machines of the Conservatoire, while his Sundays were employed in copying the plans of the spinning machines of the firm with whom he was engaged. By this means, and by his frequent visits to the workshops of Paris, he collected much valuable information on the various industries.

On his return to Mulhouse in 1817 he was to have taken up the position of mechanical constructor to the projected establishment, but family misunderstandings retarded the arrangement being carried

out at that time. Josué's father had unfortunately invested the greater part of his fortune in a land speculation which turned out disastrously; still, in the following year he succeeded in getting together the capital necessary to start a spinning concern of 10,000 spindles at Vieux-Thann, the technical supervision of which was entrusted to Josué, then only twenty-two years of age. Josué prepared all the plans for the works, and directed the construction and erection of the machines, the establishment being in active operation in 1818. This served to show that Heilmann was a man of no ordinary capacity, for few could have accomplished so much with such slender resources. At the beginning his enterprise was crowned with success. The first year's operations showed a profit of 90,000 francs, of which Josué took 33 per cent. All went well with the young spinner, and his position seemed more assured than ever when, in 1820, he obtained the hand in marriage of one of the daughters of Jacques Koechlin. This celebrated manufacturer was at once the most eminent and the most popular man of business in that part of the country, and employed 6,000 workpeople. The marriage therefore was looked upon as a very advantageous one for young Heilmann.

Up to that time Heilmann had wisely restricted

his machinery to such descriptions as had been practically proved to be good; the spinning frames of Vieux-Thann presented no particular mechanical novelty. Still, he foresaw the progress and improvement of which this department was capable, and now that his financial position permitted it, he began to have dreams of grand developments and dedicated his leisure to mechanical studies. One of the earliest results of the application of his inventive powers was an important improvement in weaving, and this was followed by the invention of valuable improvements in cotton spinning, the branch of industry with which he was more immediately concerned. About this period, unfortunately, the cotton trade experienced a severe crisis, the effect of which was severely felt by the Vieux-Thann establishment. The fact was there had been more spinning undertakings entered upon than could be kept going, and the proprietors of the Vieux-Thann works had not sufficient capital in reserve to enable them to tide over the time of extraordinary pressure, the consequence being that the business was forced into liquidation and all the fruit of Josué's labour was lost. But he did not allow himself to be cast down by adversity; he simply applied his mind with increased energy to the rebuilding of his fortunes.

There now commenced for Josué Heilmann a new

era. Finding himself all at once freed from the burden of factory management, he was able to devote his attention exclusively to mechanical investigations, and entered with strong determination upon the path of invention. In casting about for a task worthy of his powers, he was aided by a suggestion that occurred to him in his own domestic circle. He had watched his wife working patiently at her embroidery, and he had said to himself, "they spin, weave, and print by machinery, but they have never done embroidery by machinery." He thereupon resolved that he would invent such a machine. In six months the task was accomplished; he produced a frame consisting of twenty needles, which completely answered its purpose; it was an invention of great merit, and caused a considerable sensation in the industrial world. In a short time the invention made its way to England, Switzerland, and Germany, and Heilmann profited by it to the extent of 30,000 francs. For this machine the inventor also received the decoration of the Legion of Honour and the gold medal of the French Exhibition of 1834.

This was the first of a long series of inventions with which the name of Heilmann came to be associated, including improvements in spinning and weaving of an important character, notably a velvet loom capable of weaving two pieces at once. In 1841 he resumed, in



Josias Helmmann

concert with M. J. J. Bourcart, an idea which had engaged their thoughts some time previously for combing cotton by machinery. There were already combing machines for wool and flax, but the problem was more difficult to solve in regard to cotton. First of all he made himself thoroughly acquainted with the principles of the Collier woolcombing machine, which was then in operation at Malmerspach, and soon came to the conclusion that a very different system would be necessary for dealing with cotton. There are two or three different stories concerning the manner in which Heilmann first conceived the brilliant idea which afterwards became the leading feature of the combing machine which he invented. Dr. Smiles has related how one night while Heilmann was sitting by his hearth, "meditating upon the hard fate of inventors, and the misfortunes in which their families so often become involved, he found himself almost unconsciously watching his daughters combing their long hair and drawing it out at full length between their fingers. The thought suddenly struck him that if he could successfully imitate in a machine the process of combing out the longest hair, and forcing back the short by reversing the action of the comb it might serve to extricate him from his difficulty. . . . Upon this idea he proceeded, introduced the apparently simple but really most intricate process of machine-combing; and

after great labour he succeeded in perfecting the invention." This incident was seized upon by Mr. Elmore and reproduced on canvas with considerable power, the picture being exhibited at the Royal Academy in 1863. The painting was formerly in the possession of the late Colonel Akroyd, of Halifax, and was bought from him by Mr. Isaac Holden, M.P., in whose possession it now is, and by whose permission we have been permitted to take the engraving of it which forms the frontispiece to this volume. The artist has not introduced much detail; the figures of Heilmann and his daughter absorb almost our undivided attention. One important accessory which might be regarded as necessary to complete the idea of the artist is the plan of a combing machine, which, in his abstraction, the inventor has let fall from his hand, and which forms the object of a kitten's gambols. The story which gave rise to Mr. Elmore's picture however is not universally accepted. Baron Ernouf varies it somewhat. According to him it was while Heilmann was inspecting the woolcombing machinery of his friend Hartmann Liebach that the idea was suggested to him. He observed a young workgirl with her hair down. He said to Hartmann: "If I were to pass a comb deeply and forcibly through the hair of that workgirl, I should tear it all away, whereas if I began

to work with the points of the comb I should disentangle it without any harm, and not by such an operation as that of the Collier machine which tears all your wool."

Hartmann Liebach had also workmen who combed by hand, and he showed Heilmann the process, who, after having considered the work with attention for some time said he would endeavour to obtain a similar but superior result by machinery. Six months after he had constructed his first model, with which he operated with success upon samples of wool and cotton, in the presence of Messrs. Hartmann Liebach, Bourcart, and Schlumberger, the last named of whom was immediately associated with Heilmann in the working of the invention. This primitive model is still to be seen in the Industrial Museum at Mulhouse. The problem of the combing of cotton by machinery was now solved, and not only did the new machine comb the fibre better than it had ever been combed before, but by the adoption of a few simple modifications it was capable of being applied to all textile materials. This was his last and greatest invention. Its scope was so extensive and its principle so effective that it has been considered worthy to rank with Jacquard's famous loom. For cotton it was intended to supersede beating by hand and beaters, and to sort the filaments and reunite those of equal length; for woolcombing it aimed to supersede handcombing as well as the woolcombing machines

then existing ; for the floss of silk it would do away with the cards and combing by hand ; and for flax and hemp he also hoped to obtain a more perfect method.

Whatever the claims of other inventors of wool-combing machinery may be, all credit is due to Heilmann for having worked out by himself a system which at once converted this machine into one of practical utility. Contemporaneously, other inventors—notably Mr. Samuel Cunliffe Lister and Mr. George Edmond Donisthorpe—were devoting their energies to the same problem, and there is little doubt they reached pretty much the same or equal results about the same time. The French naturally claim that Heilmann was the first in the field with his improved machine and are disposed to undervalue the achievements of Mr. Lister in this direction. Mr. Lister has himself had something to say on this point. Speaking on trade subjects at a public dinner a few years ago, and referring more particularly to some remarks which had been made on his woolcombing inventions, he said, “ I have received, perhaps, more than my fair share of credit for that machine. I have always wished to do justice to those associated with me ; and Mr. Donisthorpe and myself were, I consider, the parties who mastered the difficulty. I am not jealous as to the antagonism of English inventors, but I am anxious that Englishmen should have the credit of the invention. Some people have

put Mr. Heilmann forward as the inventor of the combing machine ; but before Mr. Heilmann's patent was heard of we had succeeded in mastering all the difficulties connected with the invention. I therefore claim the combing machine as well as the spinning machine as an English invention. I do not claim it for myself ; I only claim that I am entitled to a fair share of credit for its success."

This, however, detracts nothing from the originality of Heilmann's invention. It was impossible to charge him with having stolen any of Mr. Lister's or Mr. Donisthorpe's ideas. Whatever he did was done independently and without assistance. The English patent for Heilmann's woolcombing machine was taken out in 1846. But three years before that time Mr. Lister had combed fine wool by machinery at Manningham, although not on the Nip principle, and the trade had looked with so much favour upon his efforts that a few months afterwards he received an order for fifty machines from two well known spinning firms. It is necessary to put these points clearly on record not only for the sake of establishing the fact that the English inventors did overcome the main difficulties of the problem, but in order to show that on both sides there was decided originality.

Heilmann unfortunately did not live to reap the

fruits of his inventive genius. Honour and fortune seemed at last to open out before him, but he was weighed down by a presentiment that they were coming too late for him. He himself said of his machine that it would be an ornament for the house of Schlumberger. The heavy expenses connected with protecting his invention in his own and other countries, and the still heavier cost of litigation against infringers and supposed infringers of his patent, landed him once more in financial difficulties the solution of which was rendered still more arduous by the disturbing events of 1848. His health now rapidly gave way, and on the 5th November 1848 he died in the 53rd year of his age. A few days before his death, he said to his son, "I carry with me a great consolation : the certainty that at the least prosperity will come after me."

His prediction was adequately confirmed by subsequent events. His representatives displayed much activity in introducing the combing machine into the various textile industries of the Continent and England, and in 1852 they proceeded against Messrs. Lister and Donisthorpe for infringement of patent, and obtained a verdict.

Before proceeding, however, to examine the precise effect of the English inventions it will be well to devote a little space to a more technical description of Heilmann's machine, in doing which we shall take the

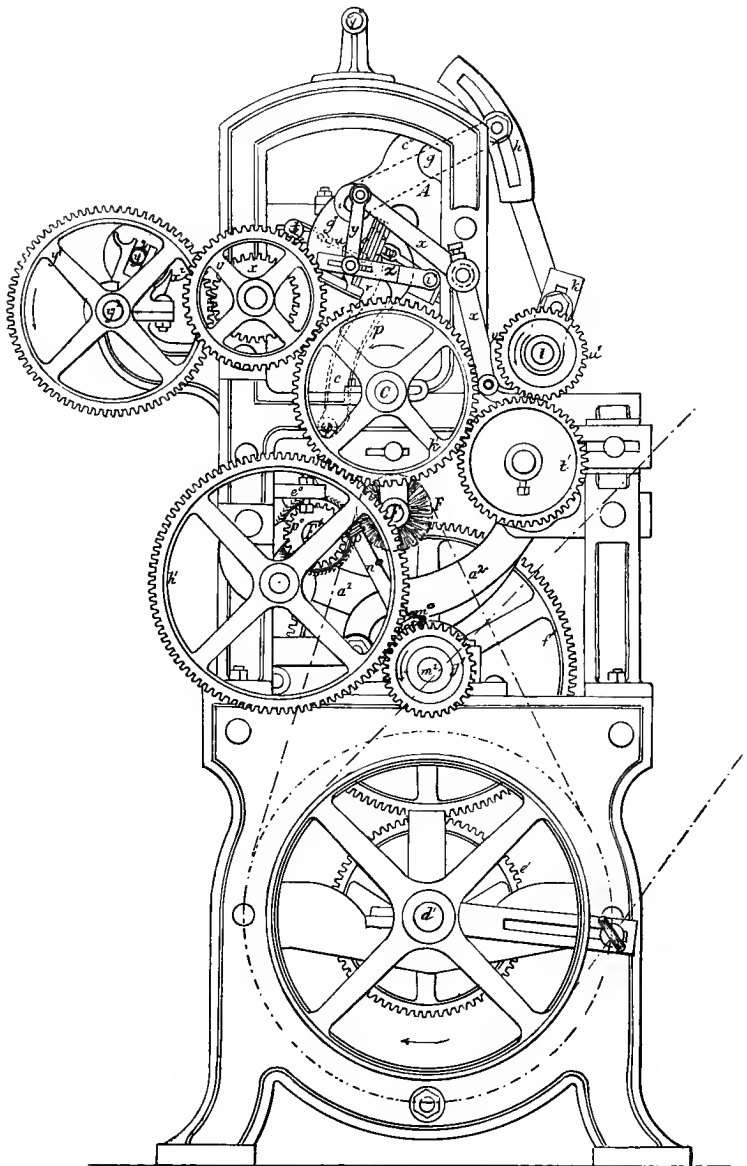

FIG. 13.—Heilmann's Machine—End Elevation.

liberty of availing ourselves of the sketch made in 1875 by Herr A. Lohren, of Berlin.

It was claimed for Heilmann's invention that it effected all the operations of combing in the most perfect manner. Herr Lohren's diagram—representing Heilmann's machine with later improvements—will serve to elucidate the various movements effected by it. The first operation, the feeding of the slivers which have to be combed, is accomplished by a feeding apparatus A and the nipper B, which forms the most essential point of the whole machine. The second operation—the combing of the fibre ends *a*—is performed by a revolving comb-cylinder *c*. For the execution of the two last operations, the combing of the portions *b*—*i.e.*, those points of the fibres which were held fast between the jaws of the nipper, as well as the combing of the ends *f*, serve an intersecting comb D, and the combing cylinder *c* in connection with a pair of rollers E E', for drawing out or breaking off the fibres. To clean the combing cylinder *c* from noils we have a circular brush F, from which the noils are removed by the card roller F' and doffer F². In Figs. 13 to 15 is shown the Heilmann Schlumberger woolcombing machine. Fig 13 is an end elevation with the working parts in that position when a fresh tuft of fibres is advanced by the feeding apparatus. Fig. 14 gives a vertical section through the working parts, showing

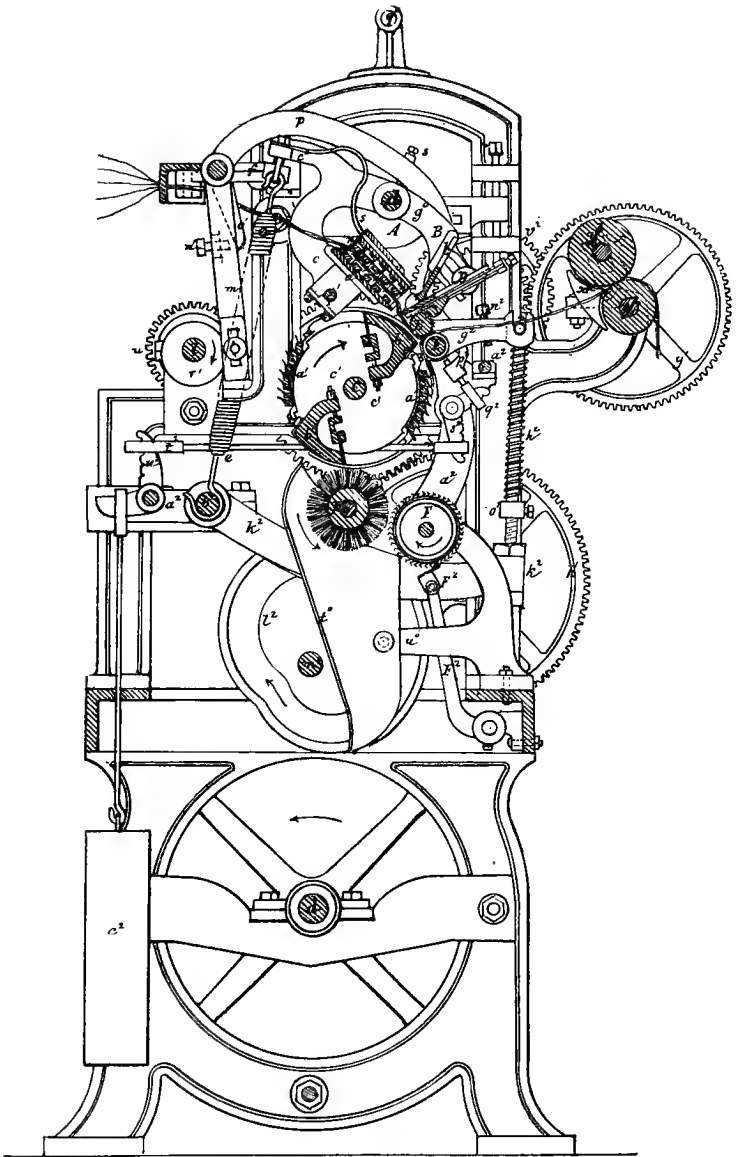

FIG. 14.—Heilmann's Machine—Vertical Section.

the position when the combed tuft of fibres is taken hold of by the drawing-off apparatus and detached. Fig. 15 is the other end elevation in the same position as Fig. 14. Figs. 16 to 22 represent the most important working parts in detail, as far as is required to comprehend the manner of working, *i.e.*, Fig. 16 a vertical section in the direction of the length of the machine, Fig. 17 the position of the principal parts during the time the nipper remains closed and a tuft of fibres is combed by the comb-cylinder. The manner of working the machine is exceedingly simple. The feeding apparatus A' unwinds the slivers from the bobbins, of which there are generally twelve upon the bobbin-stand, and brings the detached tufts of fibres by means of the nipper B quite close to the revolving combing drum C, so that they can be combed by it. After this is done, the nipper opens, the intersecting comb D is lowered into the combed end α , the drawing-off rollers E E' and the leather sector b^2 take hold of them and draw the fibre (middles B and ends γ) through the intersecting comb D. At the next passage of the combs C, the ends γ are combed a second time. Simple, however, as the working is in principle, the mechanical contrivances by which the operations are effected are really very complicated, especially as regards the nipper, the feeding apparatus, and the drawing out or breaking off apparatus, a separate description of which will be necessary.

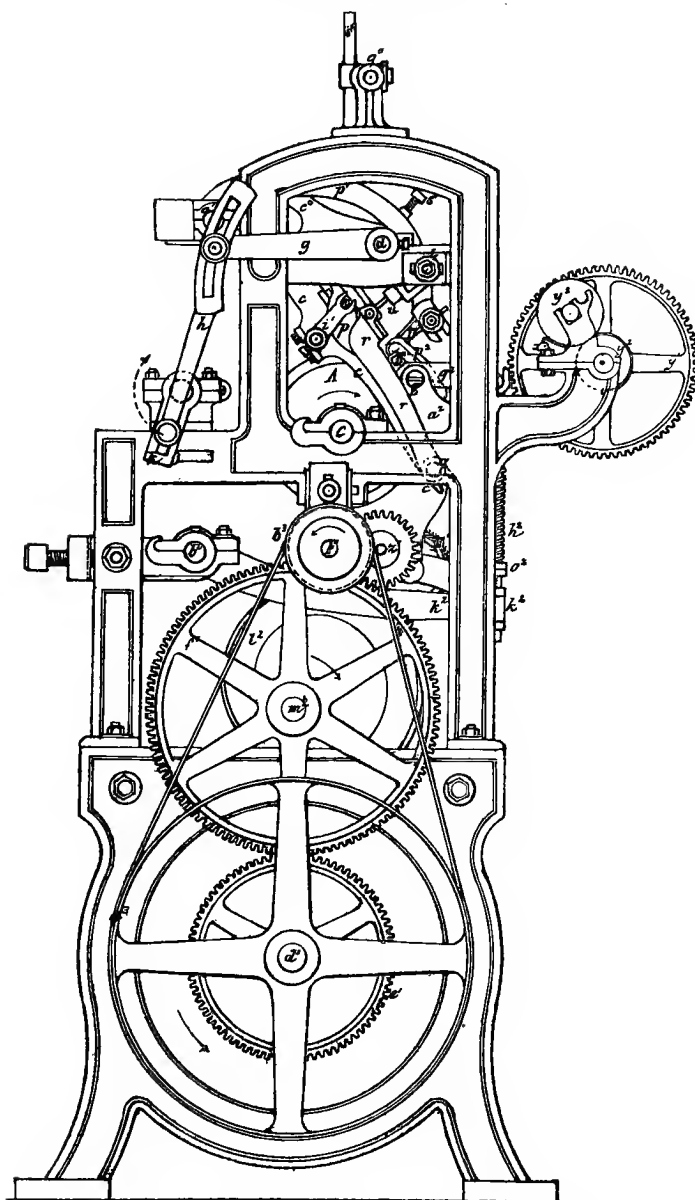

FIG. 15.—Heilmann's Machine—End Elevation.

The nipper consists of a leather-covered lower jaw a , and a top jaw with three flutes. The lower is connected with the strong double-armed lever cc' , which sits loose upon and oscillates around the shaft d , whilst the arm c' is continually drawn downwards by the spiral spring e . The action of this spiral spring is regulated by an adjusting screw, fixed upon a projection of the frame and upon which the arm c' rests when the nipper jaw a reaches its furthest position. The strong arms g' of the nipper jaw b are firmly fixed upon the shaft d . This shaft, which we call the nipper shaft, has an oscillating motion given by means of the second lever arm g , the link h , and the slotted crank k . The latter is fixed on the regulation shaft l , which has a regular rotary motion. From the arm g' the oscillating motion of the shaft d is transmitted to the top jaw b of the nipper. In descending, this jaw closes with the lower leather-covered one a , forcing it to participate in the remaining part of the oscillation during which both jaws are kept closed by the spiral spring e . When returning, the lower jaw accompanies the upper one back again until the arm c' comes in contact with the adjusting screw f . The circle segment described by the closed nipper around its axis d , is in the older machines nearly in a tangential, and in the later almost in a radial direction to the circumference of the comb-cylinder c , and can be

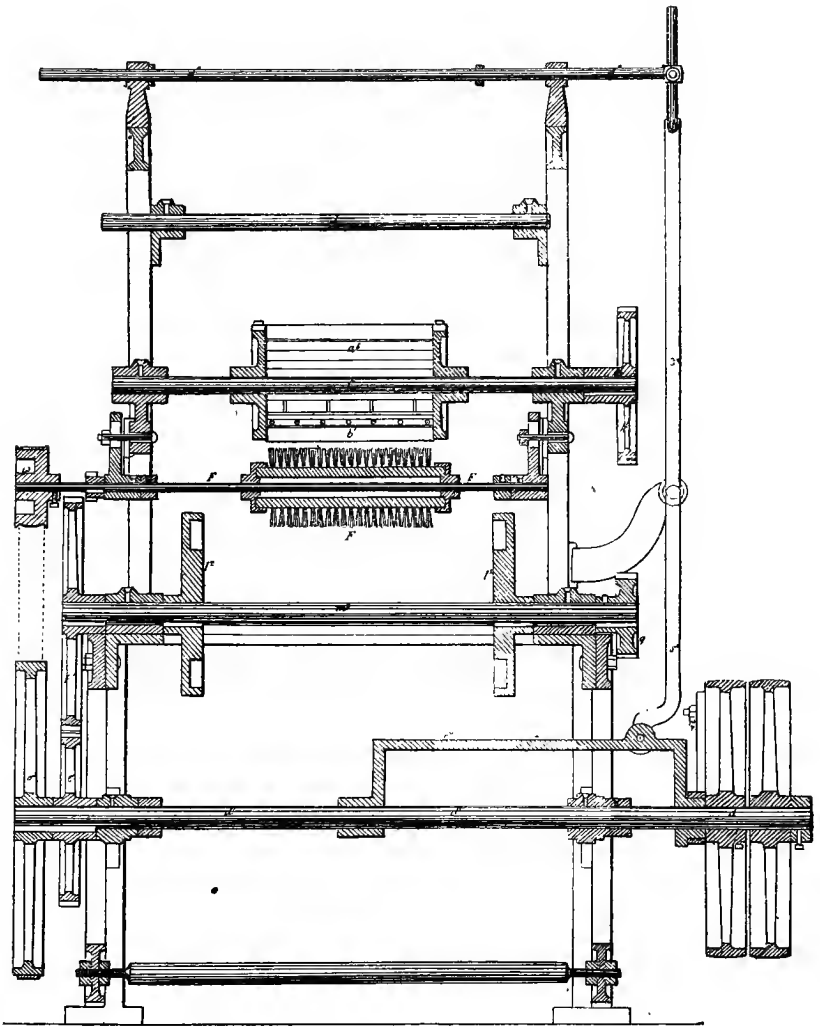
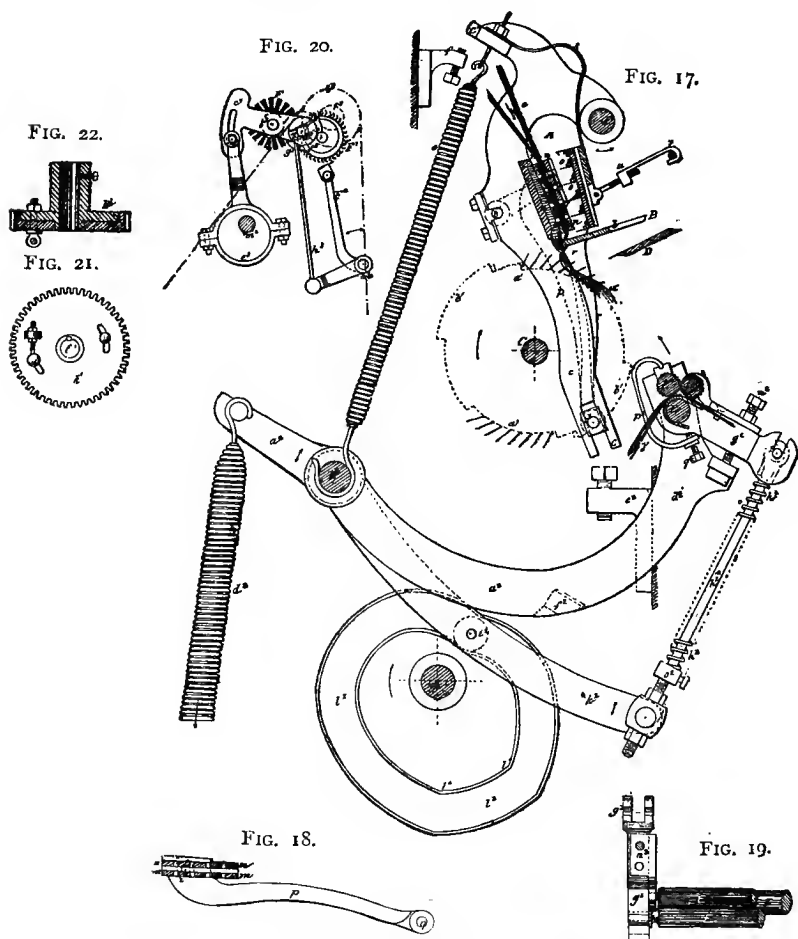

FIG. 16.—A Vertical Section of the Working Details of Heilmann's Machine.

made longer or shorter by setting the crank *k* and the



FIGS. 17-22.—The most important Working Parts of Heilmann's Machine, in Detail.

adjusting screw *f* according to the length of material which has to be combed.

The feeding apparatus A consists of two polished grates *m n*, Figs. 17 and 18, between which pass the slivers before arriving at the nipper—the feed comb *o o*, the pins of which pass through the grates and penetrate the slivers. The feed grate rests with its broad lower frame upon a planed surface of the lower nipper jaw *a*, and has a lever *p* attached to each side, Fig. 18. The lower end of the lever arm swings round a stud *q*, the bearing of which slides in the fork of the nipper arm *c*. The upper end of the arm *p* bears another stud *i*, Figs. 15 and 18, working in the fork of the lever arm *i'*. Upon the same stud *q* of the grate lever *p* is also fixed the arm *r*, which supports the flutes for the feed comb *o o*. This plate is held also in two other joints—at the extreme end of the lower arm *c*° by the springs *s*, and at the stud *t* fixed to the frame by the connecting link *u*. By this means the combs *o o* cannot follow when the nipper *a b* with the feed grate *m n* performs an oscillation, but are held fast by the link *u* and slightly turned round the axis *q* as shown in Fig. 17. This figure represents the movement when the nipper has arrived at the utmost limit of its oscillation and the projecting fringe of fibres is being combed close to the upper mouth. The feed grates *m n* have shared the oscillation of the nipper, whilst the combs *o* are held back by the link *u* and thereby withdrawn

from between the grate bars. In this position the polished bars *m n* are therefore permitted to slide upwards upon the lower jaw *a* to enclose the slivers at a place higher up. This ascending motion is given by the reversing shaft *l* by means of the cam *v*, the angle lever *x*, the connecting rod *y*, and slotted lever *z*, Fig. 13. The latter is fixed upon the same axis in the forked lever *i'*, holding the centre *i*, and grinding the feed grate up and down. As soon as the feed grate has arrived at its highest position, and the nipper begins its backward oscillation the combs *o o* re-enter between the bars *i*, as soon as the nipper then opens the whole feed apparatus is pressed down by the lappet *v*, thereby pushing out a fresh tuft of fibre through the nipper mouth.

Reviewing the operations just described, it will be found that in the feed apparatus we have three separate repeating motions, viz., an oscillating motion of the grate bars *m n*, together with the lower jaw *a* of the nipper, a partial turning of the comb fallers *o o* around the centre *g*, and their leaving and re-entering the feed grates, and lastly, an up and down motion of the feed grates *m n* upon the lower nipper jaw *a*, by means of the cam *v*. The nipper *a b* performs a single motion only, an oscillating one round the nipper shaft *d*, produced by the revolving crank *k*.

The comb cylinder or drum *c* has a regular revolving motion. Its construction may be clearly recognised from the section Figs. 14 and 16. Upon a strong shaft are fixed two disks which bear the fallers $A^1 B^2$ as well as the cylindrical segments $B' B'$, covered with cloth and leather. The screws $c' c'$ regulate the stretching of the leather cover. The fallers being set with pins can be easily disconnected and replaced by others. As the comb drum bears two such segments it makes half a revolution only for all the four operations which are required for the combing of the fibre. It is driven from the main driving shaft D' through wheels E' to K' and for a medium speed makes about 40 revolutions per minute. The intersecting comb D has the same pitch of teeth as the finest faller in the comb drum. The greater part of its length is set with pins. It is fixed in bearings; fitted to the forked end of the angle lever $O' P' Q'$ is its axis O' its shortest arm. The intersecting must descend and penetrate the combed fringe of fibres exactly at the moment when the backward movement of the feeding apparatus is completed and the combed tuft is seized by the drawing off apparatus.

The best practical rule (again to adopt the words of Herr Lohren) for the setting of this very important portion of the machine is to cause the intersector to

fall into the fibres as close as possible to the detaching or breaking off roller E, and to select the moment of falling in as late as possible. In trying to set the intersector it is made to descend gradually later and later until the sliver begins to show impurities, when it is only necessary to go back gradually to the point when it is drawn out perfectly clean. That is the right moment. The intersecting comb must enter into and penetrate the fibre ends L in a slanting position and so deeply that all fibres have to pass through it, and that during the drawing or plucking off all the noils from the fibre middles B and the ends *y* remain behind its pins. To effect this the points of the intersecting comb are brought to within one millimeter from the circumference of the combing drum *c*. The ascending and descending motion of the intersector D is produced by the reversing shaft *l* by means of the eccentric *r'* and the lever *m'* with the adjusting screw *n'* and sitting loosely upon the shaft *q'*. At every revolution of the eccentric *r'* the adjusting screw *n'* pushes against the short arm *o'*, lifting up the comb D. To prevent the intersector when descending going too low, and getting amongst the teeth of the comb drum *c* the arm *p* is also fitted with an adjusting screw *s'*, which comes in contact with shaft *d* as soon as the comb D has arrived as near the comb drum as it is desired.

The plucking-off apparatus consists principally of the leather sector v' and the two rollers $E E$, the upper one being covered with leather, the lower one fluted. Fig. 17 shows in addition a pressure roller E^2 . The plucking-off rollers make for every stroke of the nipper three different movements, *i.e.* the ascending and descending one, by means of which they approach the feeding apparatus and retreat from it; a returning one by means of which the upper roller E' describes a concentric arc around the axis of the lower one E and is pressed against the cylinder sector b' ; and an intermittent revolving one, by which all the drawing-off rollers make a partial revolution round their axis.

For a clear conception of these combined movements, upon which in a great measure depends the working power of Heilmann's machines, it is above all necessary to have a perfectly distinct idea of the various parts comprising the plucking-off apparatus. The lower roller E rests upon the upper end of the double-armed lever a^2 , which is fixed upon the shaft b^2 . The opposite arm of this lever is weighed down in the older machine by a weight o^2 , Fig. 14, in the newer ones by a strong spiral spring a'^2 , Fig. 17, thus producing on the roller arm a^2 a continual upward inclination round its axis b^2 . This upward movement is checked by the setting bar e^2 screwed to the frame of the machine, and the projection F^2 , Fig. 17, cast upon the arm a^2 . The

higher this setting bar e^2 is fixed the closer the pulling-off apparatus can be moved to the nipper and the feeding apparatus. That distance must be regulated by the length of the fibres which are to be drawn off. If it is desirable to include shorter fibres in the tops, a close approach to the feed apparatus is necessary; by screwing down the setting bar e^2 only the longer fibres can be reached, whilst the production of noils increases in proportion.

To effect this the second or periodical turning movement of the roller E round the bottom one E is ingeniously provided for. The top roller E' rests upon bearers g^2 , which turn upon the axis of the bottom roller and at the other forked end bear the pivot of the bar h^2 , Figs. 17 and 19. The bar h^2 is at its lower end connected with the lever k^2 , which works loose upon the shaft b^2 , moved up and down by means of the truck i^2 , Fig. 17, and the lappet l^2 . The lappet shaft m^2 has its regular revolving motion direct from the main driving shaft. When the lever k^2 is raised the spiral spring round the bar h^2 lifts up the lever arm g^2 , turning it round the axis of the bottom roller E , thereby changing its position from that in Fig. 17 to that in Fig. 14. The adjusting screw n^2 is fixed high above the head of the lever a^2 . When therefore the lever k^2 descends, the spiral bar h^2 will pull back the lever g^2 into its first position until the adjusting screw n^2 comes

against the lever arm a^2 , when the bar h^2 will draw down the whole pulling-off apparatus, raising thereby the weight c^2 , or in the newer machines, expanding the springs a^2 . The descending movement of the pulling-off apparatus is therefore caused solely by the action of the lappet l^2 upon the lever k^2 . The ascending one however is assisted by the weights c^2 , or the springs d^2 respectively until the projection f^2 comes in contact with the setting bar e^2 , when the bottom roller has arrived at its highest position. The movement of the lever k^2 beyond this point serves no longer to elevate the pulling-off apparatus, but produces solely the second movement, pressing the top roller E' against the leather-covered comb sector b' . The two parts E' and b' form together a regular nipper. In this position the top roller E' is turned by coming in contact with the sector b' , and transmits this motion by friction to the other pulling-off rollers E and E^2 . That is the third movement. It continues as long as the lever k^2 remains in its highest position—that is, whilst the truck i^2 runs over the eccentric $l' l'$ Fig. 17 of the lappet l^2 .

Fig. 17 shows the ends of the tufts of fibres, which have to be combed, held fast in the nipper $a b$, and brought as close as possible to the comb cylinder. The comb fallers a' are in the act of combing the projecting fringe L . The centre of the feeding apparatus, as well as the intersector D , remaining during that time

out of the fibres, the grates *m n* can move upwards upon the planed side of the bottom jaw *a* of the nipper to inclose the feeding slivers. The pulling-off rollers *E E'* are now at the greatest distance from the feeding apparatus. They now begin their upward movement, passing so near the comb drum *c* that the fibre ends *v* are combed by the segment *a'*.

Fig. 14 shows that position of the working parts when the pulling-off rollers have not only reached their highest position, but also when the top roller *E* begins to press upon the leather sector *b'*, and when the after-combing of the back ends of the fibres has been completed. The nipper is open, the intersecting comb has penetrated and cleaned fibre end *L*, and that end is now squeezed fast between the cylinder sector *b'* and the top roller *E'*. The revolving cylinder sector *b'* transmits its motion to the pulling-off rollers by friction, laying hold of and pulling off the fibre ends *L*, and joining them to the end *v* of the previously drawn off tuft collected upon an endless leather sheet which conducts them out of the machine. The noils remain behind the intersecting comb *D* and between the pins *o o*, and are taken by the comb cylinders the next time. As soon as the pulling-off rollers *E E'* have revolved round their axis a sufficient distance to lay hold of all the cleaned fibre ends *L*, the whole pulling-off apparatus moves downwards, and thereby detaches the tuft quickly

and completely from the feeding apparatus. Immediately afterwards the nipper closes upon a fresh tuft and the operation of combing recommences.

Josué Heilmann arrived at the secret of the "nip" principle by his own unaided investigations. His inventive genius, by a creative effort of the highest order, discovered the utility of this agent and successfully applied it. For this he is entitled to rank with the greatest of modern inventors, even though it could be proved that before Heilmann's patent was taken out Messrs. Lister and Donisthorpe had hit upon a similar plan.

In France and Germany Heilmann is generally regarded as the only inventor of the nip system, and the English inventors who have disputed the honour with him are set down simply as adapters or infringers of Heilmann's machine. Against this we have to set the emphatic protest of Mr. Lister, and his statement that "before he heard of Heilmann" he and Mr. Donisthorpe had surmounted every difficulty. What Mr. Lister and Mr. Donisthorpe did actually achieve however in woolcombing inventions prior to Heilmann's patent we endeavour to set forth in another chapter. Heilmann's machine, widely as it was adopted on the Continent in its application to the worsted as well as to the silk, cotton, and flax industries, did not succeed in

supplanting the English woolcombing machines in our own country. After the litigation between Heilmann's representatives and Messrs. Lister and Donisthorpe, Heilmann's English right for woolcombing was bought for 30,000*l.* by Messrs. Akroyd, of Halifax, and Mr. (afterwards Sir) Titus Salt, and they soon afterwards re-sold this right for the same sum to Mr. Lister, reserving to themselves the free use of a certain number of machines. Mr. Lister did not make the purchase in order to utilize the Heilmann machine for his own benefit, but simply to be able to get rid of it as a possible element of opposition. The superiority of Mr. Lister's and other improved English machines over Heilmann's, as far as the combing of wool was concerned, was shown in the fact that the Heilmann machine was not put into use, and that when at the expiration of its patent the trade could have had the machine free of royalty, Mr. Lister still continued to receive 1,000*l.* per machine for his, which is said to be the largest rate of patent right ever paid. But Heilmann's combing machine established itself on a firm footing away from the particular field of operation over which Mr. Lister held for a time uninterrupted sway. Six Lancashire firms paid 30,000*l.* for the English right of Heilmann's machine for cotton, and Messrs. Marshall, of Leeds, paid

20,000*l.* for the same right for flax ; so that altogether Heilmann's representatives obtained 80,000*l.* from this country for the machine. In France the invention was still more widely adopted, and although it has in recent years been superseded to a great extent by machines of a more advanced type, it is, with its later improvements, a machine of high practical value. In its original form it represented a complete revolution of mechanical ideas and a vast expansion of industrial capabilities, and must always be regarded as one of the leading inventive triumphs of the nineteenth century.

CHAPTER X.

S. CUNLIFFE LISTER.

FOR a number of years the name of Mr. S. C. Lister was the leading name in England in connection with machine woolcombing enterprises. He was first attracted to this interesting field of invention by seeing the machine which Mr. Donisthorpe had patented in 1842. This seemed to Mr. Lister to approach so near to practicability that he felt convinced it could be improved upon so as to become completely successful. He saw in Mr. Donisthorpe's invention the germ of such a machine as would do away for ever with handcombing, and he was quick to perceive that the inventor who could achieve the perfect machine might reckon upon drawing immense royalties from the cotton and worsted lords of the North. Such a machine would not merely lessen labour, it would abolish altogether a handicraft that had existed for hundreds of years, and in which many thousands of workmen were then engaged. The prize

was worth the winning, and Mr. Lister resolved to make a desperate attempt to carry it off. So he at once placed himself abreast with the latest inventive efforts by purchasing half of Mr. Donisthorpe's patent for £2,000. Then he began his own woolcombing labours, and devoted himself so persistently to this one object that in a very short time his efforts roused spinners from their long apathy and indifference, and they began to look hopefully upon his undertaking. Meanwhile, Mr. Donisthorpe was not idle. He too was concentrating all his faculties upon the same task, and endeavouring to improve upon what he had already done. At this juncture however Mr. Lister entered into further negotiations with Mr. Donisthorpe, with the result that the latter sold to the former his remaining half in the woolcombing patent for £10,000. It was part of the bargain that Mr. Donisthorpe was not to be at liberty to bring out a rival machine, supposing he could, although he was permitted to work seven combing machines at Leeds free of royalty.

Before pursuing this part of our history further however it will be interesting to say something about Mr. Lister's previous career, which had not been altogether without distinction. He was descended from an old county family, the Cunliffe Listers of Manningham, and was born at Calverley Hall, near

Leeds, in the year 1815. When Mr. Lister was some two or three years old, his father, Mr. Ellis Cunliffe Lister, removed to the family mansion of the Listers, Manningham Hall, and at this seat Mr. S. C. Lister continued to reside for nearly half a century. According to Burke, the Cunliffes are of Saxon origin, and, as appears from the records of Clitheroe Castle, they were settled in Lancashire from a very early period. Adam de Cunliffe was in possession of the estate of Cunliffe, near Billington, in the time of Edward I., and the estate was held by his descendants until the Wars of the Roses, but lost during the reign of Henry VII. The present head of the Cunliffe family is Sir Robert, fifth baronet, living near Liverpool, and members of the family represented that place in Parliament for many years during the first half of the last century. When Bradford became a Parliamentary borough, in 1832, Mr. S. C. Lister's father, in conjunction with Mr. John Hardy, father of Viscount Cranbrook, was elected one of its first members. With such connexions it was never imagined that Mr. S. C. Lister, although only a fourth son, would drift into commercial pursuits. Indeed, his parents intended him for a very different life. From early youth he had been taught to regard the Church as his future field of labour, and not only was he educated with this view, but his grandmother made the thing more definite by bequeathing

him the rectory of Addingham, on the express condition that he should take holy orders.

When Mr. Lister became old enough to have a will of his own, he let it be known that the career his family had marked out for him was one that he had a decided objection to adopt, and he must have shocked his friends very much when he announced to them that he meant to "go into trade." But he made his resolve and stuck to it, and indeed there were in those days many inducements for a young man of spirit and insight to make such a departure. The industrial world was undergoing a marvellous transformation ; the period of hand labour was fading into extinction, as far as the textile manufactures was concerned, and under the impetus of steam and mechanical invention, trade expansions were taking place which presented splendid opportunities to men of inventive skill and business aptitude. In no part of the world was greater activity, being displayed than in the West Riding of Yorkshire. Mr. Lister saw rising up around him in all directions, multitudes of factory chimneys, indications of mighty workings in which he longed to be taking part. So, when it was seen that no other sphere of labour was likely to be acceptable to him, his father reluctantly consented to his forsaking the Church for the factory, and, when his course of education was finished at a private school at Clapham Common, instead of passing

forward to the University, as it was originally intended he should have done, he was placed in the establishment of Messrs. Sands, Turner and Co., Liverpool, where he gained his first commercial experience under rather favourable conditions. At the outset he was committed to the counting-house, and worked very diligently there for a time, but as his capabilities were gradually revealed it was found profitable to employ him in more important duties, and he undertook several trips to the United States for the firm. In America he saw much that interested him, and was careful to inform himself of the position of industrial affairs and the progress of invention in that country. The knowledge he thus acquired was not only of great use to him but it gained him some little fame on this side of the Atlantic, for the era of ocean steamers had not yet set in, and a voyage to the States was looked upon as a hazardous undertaking, worth boasting about by those who successfully accomplished it. It was on this account that he came to be known amongst his friends as "American Sam."

After serving this period of industrial noviciate with Messrs. Sands, Turner, and Co., and on attaining his majority, Mr. Lister secured the co-operation of his brother, Mr. John Cunliffe Kaye, and in 1838 they entered into business together as partners at Manningham. Here their father erected them a mill, and they

proceeded to manufacture worsted stuffs according to the best mechanical means then at their disposal. It was now that Mr. Lister was brought into personal contact with the thousand and one problems, solved and unsolved, of the worsted manufacture. Much as had been realized in the way of mechanical adaptability, and the subjugation of natural forces to industrial purposes, he could see that there was still a great deal left to be completed. The power-loom invented by Dr. Cartwright had only been in use some ten years for the weaving of worsted fabrics, and Mr. Lister had witnessed the fierce opposition with which the introducers of it at first had to contend, fatal riots involving the destruction of a great quantity of machinery having taken place in the town of Bradford, of which Manningham formed a suburb. It was in the preparatory processes that there remained the most to be done. As regarded the two leading operations of spinning and weaving, matters were in a fairly perfect condition, but in the earlier stages of manipulation—before the raw material came into contact with the spinning-frame—machinery was far from wielding the power it did in other departments of manufacture, for there was still retained in those initial processes an immense amount of hand labour that inventors were puzzling their brains to supplant by mechanical methods.

For a couple of years the two brothers carried on their enterprise together with success. In consequence of the death of Mr. W. C. Lister, Mr. Kaye's altered position demanded that he should retire from the partnership. Mr. S. C. Lister had now the sole control of the business, and for a year or two longer he continued to conduct it on the old lines, without attempting any new departure. But in 1842, as we have seen, he was brought into touch with the woolcombing problem, and quickly made himself master of the situation in regard to that particular branch of invention. When he became possessed of the whole of Mr. Donisthorpe's patent he was in a position to take the lead in machine woolcombing, for as yet there were no other inventors in the field who could claim to have advanced the machine so near to the point of practicability as Mr. Donisthorpe had done.

Mr. Lister did not achieve success with the woolcombing machine at a bound. Referring to this period, Mr. Lister once said, "In the year 1842 I was a young man, with comparatively small means—being a fourth son—whatever brains I had. I then turned my attention to woolcombing, and took my first lesson from Mr. Donisthorpe. But then, unfortunately, Mr. Donisthorpe, like all the earlier inventors of woolcombing machinery—like the learned and clever Dr. Cartwright—had been ruined ;

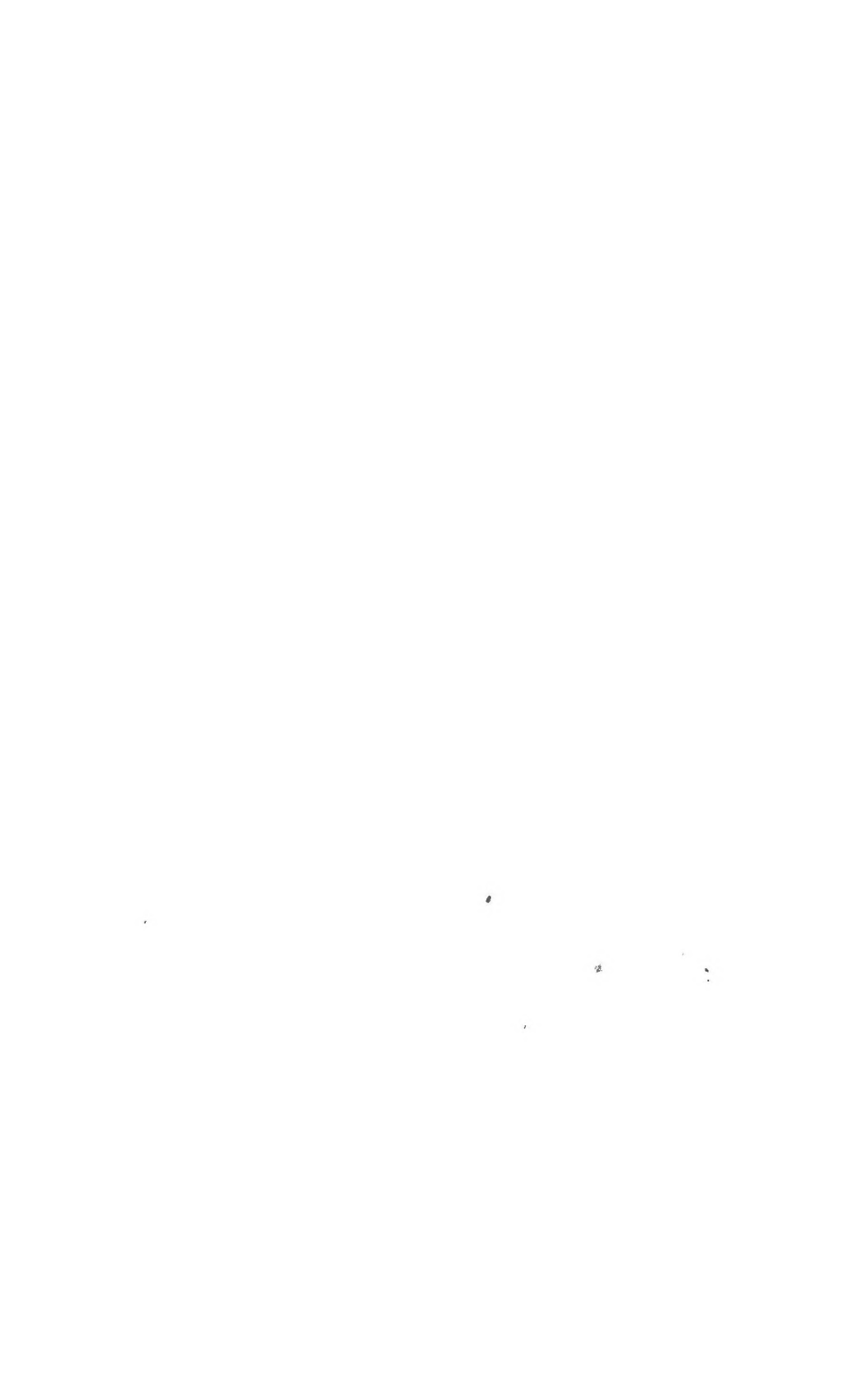

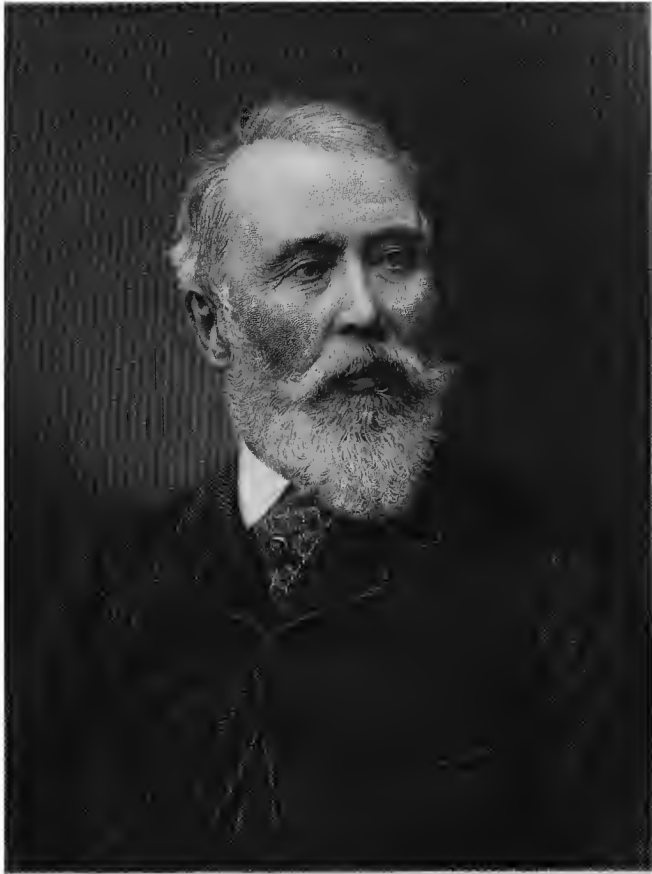

Joseph Lister

somehow or other it happened that they all got a white elephant which ate them up. Being young and foolish, I bought a white elephant myself; I bought it from Mr. Donisthorpe, who was very anxious to part with it. After I had trotted it about, asking everybody to buy it, or accept it for nothing, and being at last in danger of being eaten up by it, I set determinedly to work to see if I could not bring the beast into order. The fact was, the machine was not in a fit state to present to anybody—it would not work.” The prospect seemed so bad that Mr. Lister offered to let Mr. Donisthorpe have the patent back at a considerable loss, but the offer was declined, and Mr. Lister was left to struggle with it as best he could. But, after a while, and when nearly his last shilling had gone in experiments, Mr. Lister effected several alterations in the machine, took out sundry patents, and made the invention practically useful.

Messrs. Lister and Donisthorpe had applied themselves to the improvement of the woolcombing machine with remarkable energy and zeal. Early and late they had laboured together in secret in a corner of the Manningham factory, patiently and persistently endeavouring to make their machine perform its work with greater efficiency, for, with all its improvements, it was still surpassed in delicacy of result by the hand-comber. They were not long in reaching more perfect

stages. In 1843 Mr. Lister succeeded in combing at Manningham the first fine wool (Botany) that was ever combed by machinery, and in the latter part of that year had effected such further improvements that two of the oldest and largest spinning firms in the trade—Messrs. Wood and Walkers, and Messrs. John Rand and Sons—were so satisfied with the machine that they gave Mr. Lister an order for upwards of fifty machines. From this time Mr. Lister may be considered for many years to have commanded the woolcombing trade. It was his machinery that dealt the death-blow to the handcomber, and established machine-woolcombing on a successful basis. And he had his reward. For a considerable period his machine was in general use in the worsted trade, and for each of them he received a royalty of 1,000*l.*, the largest patent right ever paid it is believed.

The three difficulties which Lister and Donisthorpe had to overcome were to comb perfectly, to prevent “clogging” in the process, and to reduce the proportion of “noil” or waste in the course of the operation. When they took the matter in hand, there was no machine existing that answered all these requirements ; but by successive efforts they ultimately arrived at the “nip” machine, in which the tuft of wool was drawn by a nipper through a gill comb. To put it briefly and clearly, they drew the wool through

the teeth horizontally, while Heilmann drew the teeth through the wool in a circle, that is, worked the ends of the wool by a circular carder. This principle had previously been applied successfully in the silk and flax trades, but it was long regarded as impossible to bring it into operation in the combing of wool. The difficulty was surmounted however not only by Lister and Donisthorpe, but by Heilmann, for the latter of whom priority is claimed, though Mr. Lister contends that he and Mr. Donisthorpe had hit upon a similar plan "before they had ever heard of Heilmann."

We have already, in a previous chapter, dealt with Heilmann's masterly invention of the "nip" principle, by which an entirely new departure in machine woolcombing was effected. It was only by the addition of this principle to the machine of Lister and Donisthorpe that Mr. Lister was placed in a position to rule the woolcombing industry of this country. Without this important new feature Lister and Donisthorpe would doubtless have had to make way for Heilmann's own machine, and, as it was, that machine had to be reckoned with before Lister and Donisthorpe's "nip" could have a fair field. Heilmann's English patent was taken out in 1846, but it was not before 1850 that Lister and Donisthorpe began to utilise the "nip" principle, and not until 1851

that their "nip" machine could be regarded as perfected.

In Lister and Donisthorpe's patent of the 18th July, 1849, it was evident that they were approaching the desired end.

The first part of that invention related to preparing wool, and in applying several feeding apparatus to obtain uniformity. Theretofore it had been usual to employ only one feeding apparatus, but they used two, but by preference more than two, feeders simultaneously to deliver wool on to a cylinder, and thus accumulated a series of layers on such surface, by which a more even accumulation of wool might be obtained, and the same might be continuously doffed in place of making a continuous band of wool around the cylinder. The second part of the invention consisted of a mode of feeding wool on to a porcupine cylinder moving past a feeding apparatus, in place of simply drawing off continuously wool from the feeding apparatus by the teeth of the passing surface. And this improvement consisted of causing the porcupine cylinder or moving surface of teeth to progress slowly before the feeding apparatus, which was to have a lashing movement in like manner to those used for lashing wool into combs. The object of the third part of the invention was to place wool upon combs with less stress and injury to the teeth than by the ordinary

methods, and to prevent the wool from curling round the teeth. A plate or plates was applied, which, every time the wool was lashed on to a comb, descended between the rows of teeth, and pressed the wool against the head of the comb, by which the wool was more effectually retained than when the pressure was applied to the back teeth. This mode of feeding combs, amongst other advantages, would admit of the use of finer combs without the hazard of injuring the teeth. The fourth part of the invention consisted in holding the wool upon combs whilst being worked by inserting a plate or plates between the rows of teeth of the combs, and applying sufficient pressure so as to hold the wool between the plate and the head of the comb; this would allow of the end of the fibres being combed out by the working comb without robbing the holding comb. The fifth part of the invention referred to stretching the fibres of wool, and then fixing them by steam. After the wool had been scoured it was drawn into a sliver and tightly wound on to a bobbin, the barrel being perforated with holes to allow of the steam acting from the outside as well as the inside of the bobbin. It was then placed in a steam chamber and allowed to remain from one to twelve hours. This process would be found of great value in assisting wool combed by machinery to spin; and the inventors laid particular stress on steaming and fixing the fibres of

wool after being combed and extended by mechanical means. The sixth part of the invention consisted in causing dyers' tubes to be employed in wool-spinning frames.

The "nip" principle was elaborated in Lister and Donisthorpe's patent of the 20th March 1850. We give a reproduction of the section drawing which accompanied the specification of that date, to which the following description was appended:—

The drawing shows a section of the main part of the machine. *a, a*, are the carrying combs receiving the wool, fed from the nipping means in detached pieces, and accumulated on these combs it is conducted forward to the draw off. The nipping means consists of bars *b, b*, and the endless apron *c*, which receives the wool and draws out a portion therefrom, and brings it towards the circle of combs, one of the brush surfaces alternately coming into position and placing it on to the combs *a*. *e* is the main axis of the apparatus. Upon this shaft *e* are fixed bevilled pinions *e*², which drive the bevilled pinions *f* on the axis *f*¹, and thence to the axis *f*³, upon which are screws for giving motion to the gills *d*. The shaft *e* also by intermediate wheels gives motion to the roller *b*², which carries the bars *b*, capable of sliding freely within the cylinder, *b*² having a constant tendency to be pressed outwards by the springs *b*³; but the bars *b* are controlled by the rims of

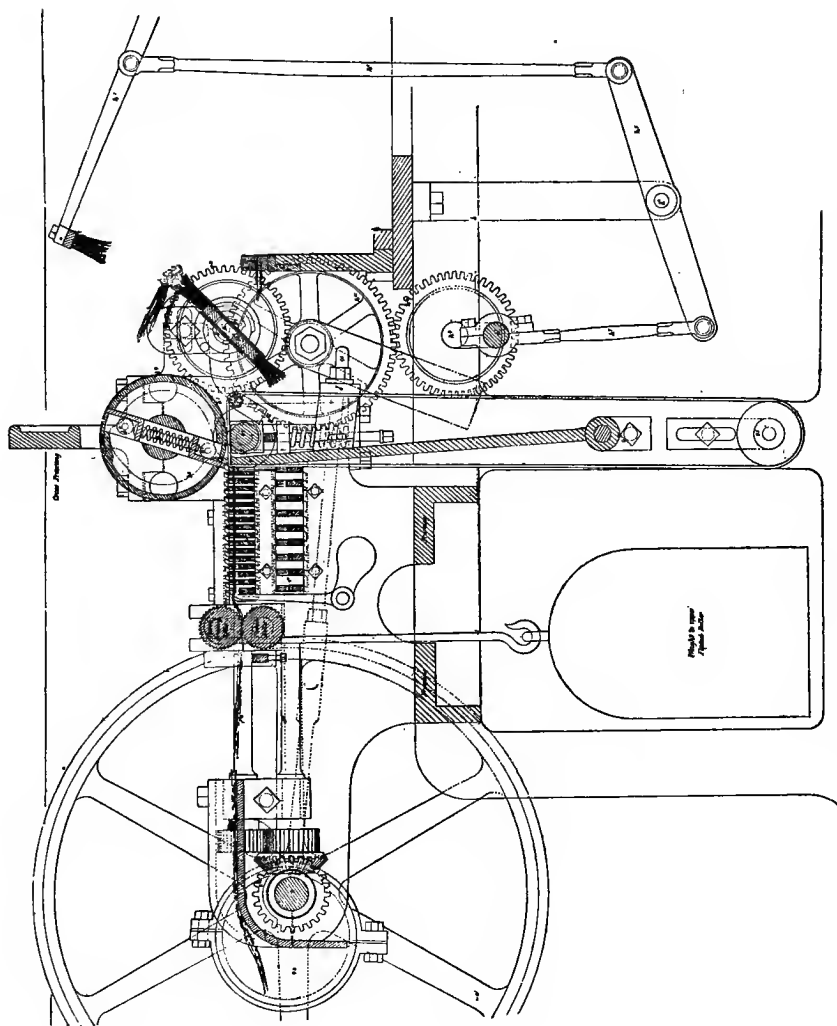

FIG. 23.—Section of Lister and Donisthorpe's "Nip" Machine.

plates affixed to the framing of the machine. There are cam surfaces on the inside of these rims against which the rollers b^6 , carried by the bars b , run, thus controlling their motion ; and the bars b each come out of the surface of the cylinder b^2 just as they come round to the point where the gill combs deliver the wool, which is then nipped between the bar b and the apron c , drawing out and detaching a quantity of wool from the screw gills. The apron c is conducted over the upper edge of the plate c^1 and over the roller c^2 , which travels at the same surface speed as the cylinder b^2 , by means of the toothed wheel b^7 , on the axis of the roller b^2 , driving a pinion on the axis of the roller c^2 . Thence the apron c passes over the guide roller c^4 and under the roller c^5 . The upper edge of the plate c^1 supported in bearing c^6 , by reason of the apron c , constantly rests against the roller c^2 , but when the nip is to take place the upper edge of the plate c^1 , with the part of the apron c which is passing over that edge, should be in position underneath, and forms a corresponding holder to the bar b in effecting such nip. For this purpose ears c^7 are attached one on each side of the plate c^1 and projecting on each side of the machine. These ears have holes in which slide the ends of the eccentric rods c^8 . The other end of each of these rods c^8 embraces an eccentric c^9 on the shaft e . In the revolution of these eccentrics the end of the rods c^8

slide freely in the holes formed through the ears. But these rods, just when the nip is to take place, draw the ears, and consequently the plate c^1 , a short distance towards the gill combs. Then, as the eccentrics revolve, the rods c^8 slide in the ears, and the plate c^1 goes slightly forward with the apron to the roller c^2 , which then acts with the apron in the further movement of the apron and the nipper bar b . As the detached portion of wool comes forward with the holding instruments b, c , the edge is received on one of the brush surfaces g carried by the frame g^1 affixed to a spindle which carries the toothed wheel g^3 , which receives motion from toothed wheel b^7 . The brush then takes the detached portions of wool and successively deposits them on the teeth of the passing comb a , where they are accumulated and pressed down into the teeth by the brush h , which then recedes out of the way for another similar operation. This brush h is affixed to one end of the lever h^1 and is actuated from the axis h^9 by means of the crank h^8 , link h^7 and intermediate lever mechanism. The axis h^9 is supported in the framing of the machine and receives motion from the axis of the roller c^2 by the pinion h^{10} , driving the intermediate wheel h^{11} which gives motion to the toothed wheel h^{12} , affixed on the axis h^9 . In place of the passing combs being circular they may be in straight lines, and in place of their being moving combs

they may be fixed, and only removed when charged with wool. When a circle of teeth is employed each of the brushes *g* is formed in three portions, each of the outer portions turns upon a centre. The two centre ones are connected together by plates, and they have also other plates the ends of which project beyond the length of such middle portions of the brushes, and such projecting portions have slotted openings to receive headed pins, by which the outer and centre portions of each of the brushes are connected together, whereby any motion given to the centre portions will control the position of the end portions. One of the brushes is constantly pressed into a straight line by a spring, whilst the other has a constant tendency to be drawn in a curved line. One end of a lever presses against the centre portions of one of the brushes, the other end passes into the course formed in the plate. This course is formed as a cam course, to give motion to the lever, so that the brush against which the lever works may be pressed in a straight line when passing the apron *e*, whilst the other brush will have a curved form given to it. In withdrawing the detached portions of wool by the nipping instruments, the noil will be left in the teeth excepting where the nippers have hold thereof. Then, the noil left from the portion last detached will be brought forward at the next nipping. And such nipped portions containing the refuse will be

laid on to the combs *a*, and the cleansed ends of all such detached portions of wool will project out from those combs *a*, so that in drawing off the wool the noil will be left in the combs *a*. The use of screw gills or series of teeth acting in like manner to bring up successive quantities of fibre when combined with the use of drawing out detached quantities of fibres therefrom is mentioned as a highly useful part of the invention.

In subsequent years, Mr. Lister took out several further woolcombing patents, but no material improvement was added to the "nip" machine after 1851. These new inventions were mostly modifications of the "nip" principle, but by one and another he was able to surround his machine with a variety of safeguards which by anticipating fresh contrivances rendered his patent impregnable. So difficult was it for any other inventor to make headway against him that most of those who attempted to do so found themselves forced into litigation and adjudged infringers.

It is generally believed—at all events, in this country—that Mr. Lister and Mr. Donisthorpe arrived at their "nip" invention by an independent effort, and were in no way indebted to Heilmann for the idea of that principle. Still Heilmann was the first to reach the Patent Office with the improvement, and therefore was in a position, when Lister and Donisthorpe's "nip" machine was brought out, to obtain an injunc-

tion against them for infringement. Heilmann's patent was taken out in 1846, but no machines of his were put to work in this country before 1851. The fact remains, for all that, that Heilmann's representatives were successful in their litigation with the English inventors, although this success did not insure the adoption of the Heilmann machine in this country for the worsted trade. After the injunction had been obtained, as we have seen, Messrs. Akroyd and Titus Salt bought Heilmann's patent right for woolcombing in England for 30,000*l.* and these gentlemen subsequently sold the right to Mr. Lister for the same sum, reserving to themselves the liberty of using a certain number of machines free from royalty. In this way Mr. Lister was able to remove his rival from the field, and to keep his own machine in the front position. This he did completely, and it is a strong proof of the superiority of his machine for the worsted manufacture that when, later on, Heilmann's patent expired and his invention could have been utilized by the trade free of cost, they preferred to comb with Mr. Lister's machine although they had to pay him the large royalty of 1,000*l.* per machine. As we have dealt more particularly with Heilmann and his machine however in another chapter, it is unnecessary to make any further reference to the matter at this point.

It says much for Mr. Lister's business sagacity and

capacity that, with so many rivals to contend with, he was able to drive them all for a time into the background. Whenever and wherever a danger threatened he succeeded in either crushing it by legal enforcement or in removing it by purchase. Thus, as far as England was concerned, he came to possess a practical monopoly, and in turning it to the best account only pursued those business tactics which others would gladly have imitated had they been fortunate enough to obtain the opportunity.

We have seen how Mr. Lister and his coadjutor Donisthorpe identified themselves with the Nip principle in the early stages of its development. It is well that we should now attempt to show what the Nip machine was in its latest and most perfect state, when, until the Noble system in England and the Square Motion machine in France were brought into formidable competition with it, it held almost supreme sway. According to Lohren, the Nip machine of Lister fulfils all the elementary principles of perfect combing, and yet it has neither a special combing apparatus nor an intersecting comb, but only a feeding apparatus. In this feeding apparatus, however, are combined the effects of three of the operations necessary for good combing, viz., the filling in of the fibre, the combing of the fibre-ends, and the adequate preparation for the combing of the middle

portion. Herein lies the importance of the invention and its ingenious originality. "It could only be accomplished," says the authority just mentioned, "after Heilmann had invented his celebrated 'nipper,' and forms therefore a combination of the inventions of Cartwright and Heilmann."

We cannot do better at this point than adopt the description of the latest form of Lister's Nip machine as given by Lohren, for whom the merit of independent observation and technical knowledge may at least be claimed. The machine in its general construction is shown in Figs. 24, 25, and 26, and consists, as usual, of—

A revolving comb-ring, *A* ;

One or two feeding and combing apparatus, *B, C* ;

A stroker, *D* ;

A drawing-off apparatus, *E* ;

And the noil rollers, *F*.

The comb-ring *A* has the usual shape, and is heated by the circular steam chest *a* by means of the steam pipes *a*¹. This combing is driven from the main driving shaft *b* by means of the wheels *a*² to *a*¹³, of which the wheel *a*³² is geared with the teeth inside the comb-ring.

Fig. 25 shows the arrangement of one of Lister's machines with one drawing off and two feed heads *B, C*, the latter being placed at right angles to each other.

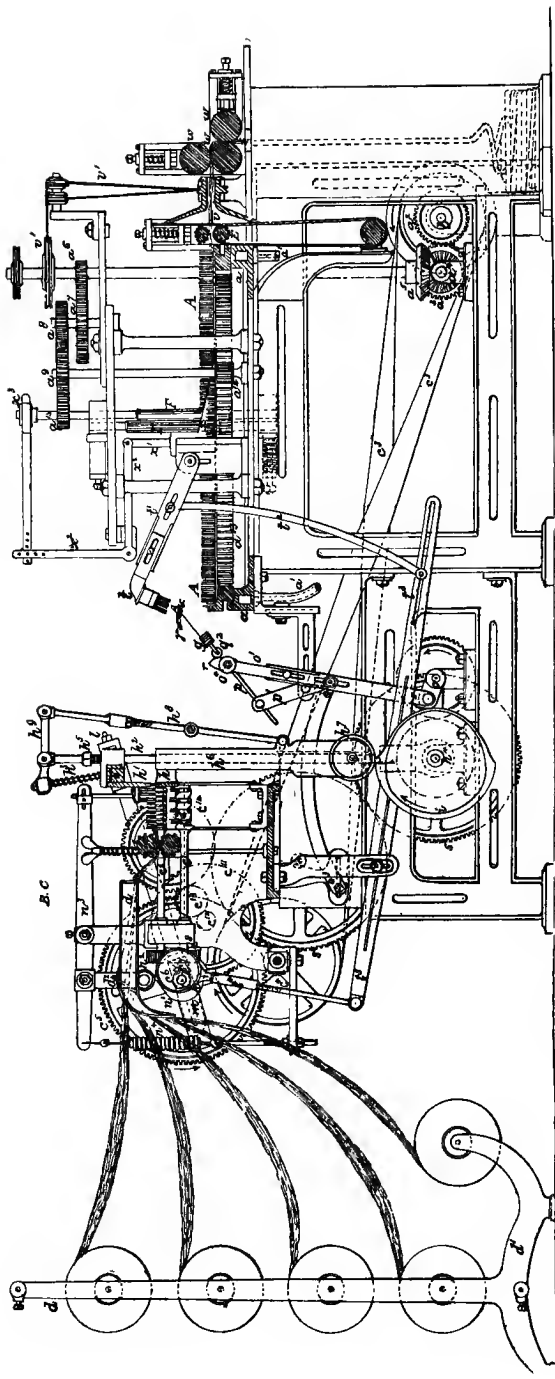

FIG. 24 --General View of the later form of Lister's Nip Machine.

They are fixed firmly upon the frame of the machine, but are movable upon the slides *R R*, and can be set to suit the length of the material which has to be

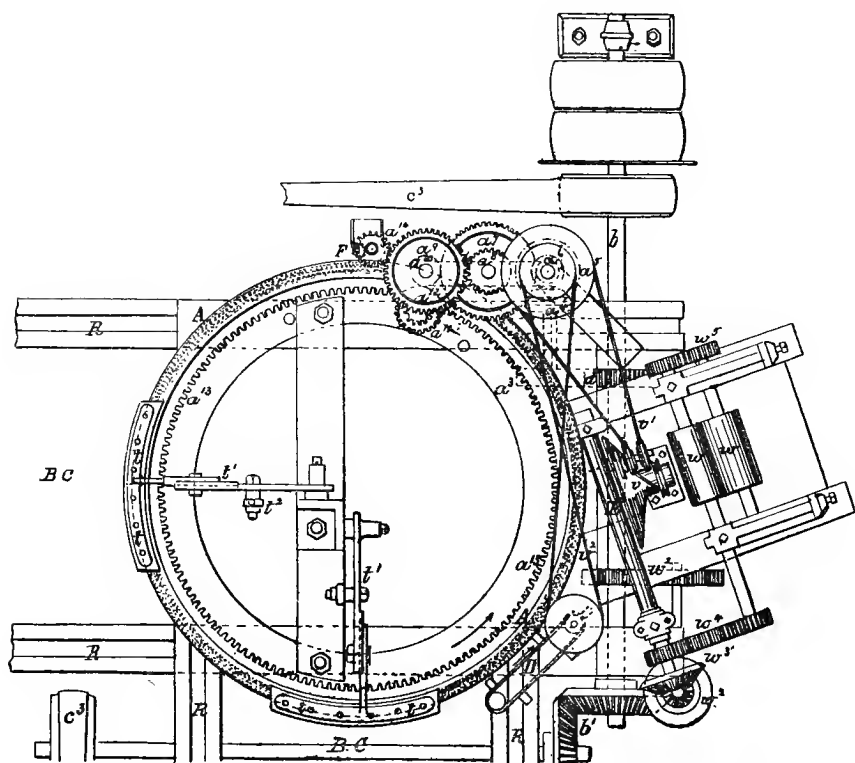

FIG. 25.—Sectional View, showing one drawing off and two Feed Heads.

worked upon the machine. The front part of this feed head is constructed like a gill box without drawing rollers. It consists of a polished guide plate *d*, the fluted drawing in or feed rollers *e e*, and the

fallers $c c$ in the usual manner. The balls from which are delivered the slivers for feeding the machine are placed into the bobbin-stands a^1 , and are conducted over a divided plate d^2 to the feed rollers $e e$. The lower screws c^1 receive their regular revolving motion from the main driving shaft b , by means of the belt c^3 , the spur wheels c^1 c^5 and the conical wheels c^8 c^9 . The top screws c^2 are connected with the bottom screws by the wheels c^8 c^9 . The feed rollers $e e$ are driven by the wheels c^{10} to c^{14} .

So far we have found in Lister's machine only old and well known mechanisms. The peculiarity, however, consists in the nipper $h h^1$, which takes hold of the fringe of the fibres projecting from and drawn forward by the fallers, and then deposits the drawn out portion of fibres upon the carrying comb g . The latter places them in the teeth of the comb ring A . The nipper consists of two jaws, the lower one h with a grooved edge, the upper one h^1 with a polished and rounded off edge. The upper jaw slides upon the lower bar h^2 , and is pressed down by the spiral spring h^3 ; the lower bar h^2 swings its lower end round the shaft h^4 , and its highest position is fixed by the adjusting screw h^5 . The lower jaw is fixed upon the tube or brush h^6 , which slides upon the bar h^2 , and bears at its lower extremity the truck h^7 , and at its side the connecting rod h^8 . The latter operates upon

one end of the double-armed lever h^9 , the other end of which presses upon and confines the spiral spring h^3 . The opening and closing of the upper is caused by the cam or lappet i keyed upon the revolving shaft h^4 , and upon the circumference of which runs the truck h^7 . The pressure between the two jaws of the nipper is regulated by the nuts upon h^2 and h^3 and the spirals h^3 . Besides the opening and closing movement of the jaws of the nipper, by which it takes hold of the fringe of the fibres, a second movement is required to draw out the fibres from between the teeth of the fallers and transfer them to the carrying comb. This motion is produced in nearly an horizontal direction from the shaft K by means of the slotted cranks m , and the connecting rods l , which are connected with the top jaw of the nipper by adjustable bearings. The following describes the action of this nipper. At the moment when one faller c has fallen from the top into the bottom screw, and the next following faller has advanced the thereby liberated fringe of fibres as far as the screws will permit, the jaws of the nipper close upon this projecting fringe (L) as far back as to bring the whole portion of fibre held by the faller just descended, and which portion contains the noils and impurities, to the outside of the nipper. As soon as the fringe of fibres is nipped in between the jaws, the detaching move-

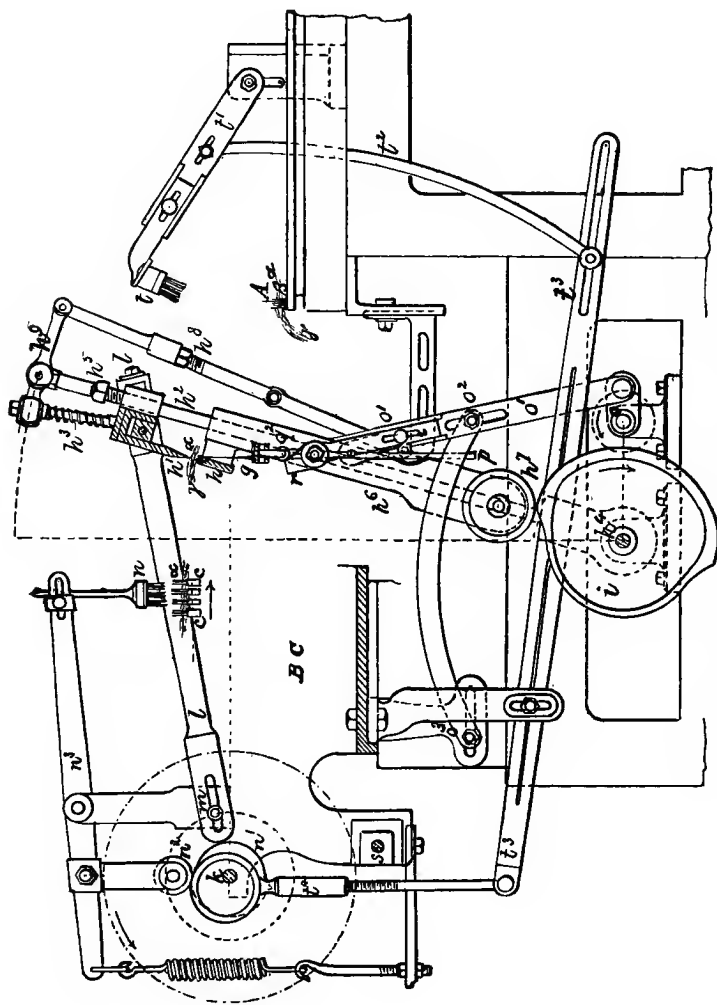

FIG. 26.—Another Sectional View of Lister's Nip Machine.

ment begins by means of the crank m . To effect thereby the combing of the back end (Y) of the fibres, the brush n descends into the pins previous to the fibre being detached, and remains in that position during this operation. The motion is given to this brush from the shaft K , by means of the lappet n^1 , the truck n^2 , and the lever n^3 , tension being given by the spiral spring n^4 at the opposite end. The carrying comb g receives the ends (L) of the detached tuft of fibres (Fig. 26) and places the same so far over the teeth of the comb ring A , that not only the uncleaned ends (L), but also the still impure middle portion (B) of the fibres is deposited within them, thus only leaving the combed ends (Y) projecting from the comb ring.

From this will be perceived that the drawing off apparatus will produce a sliver of fibres combed perfectly clean along their entire length. The work of this carrying comb is one of the most important features of Lister's machine. Figs. 27 and 28 show this comb separately. The same receives three combinedly separate and distinct motions—a vertical one, a horizontal one, and a change in the position of the points of its teeth from a straight line (Fig. 27) into a curved one (Fig. 28). The first is produced from the crank o by means of the bar o and the lever o^2 o^3 , the second by the rod p , to the upper end of which the carrying comb is fixed. This rod turns upon the

axis o^4 in the connecting rod o^1 , sliding with its other end in a swivel upon the guide bar p^1 . The third motion which changes the straight line of the points of its teeth into a curved one, and back again to a straight one, is produced by the teeth fixed into a curved spring plate q (Figs. 27 and 28), which by the

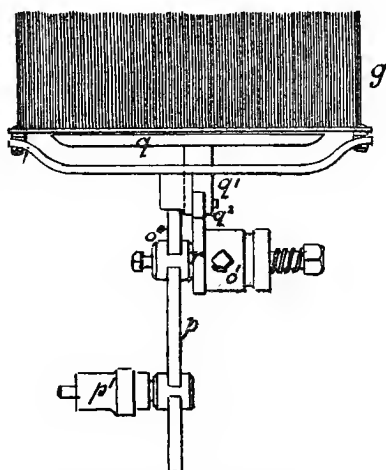

FIG. 27.—The Carrying Comb.

pin q and the truck q slide upon the slanting projection r on the connecting rod o^1 .

These separate parts have to be arranged by a practical hand in such a manner that, when in the act of receiving the tuft of fibres, the carrying comb advances in as near as possible a perpendicular position close to the nipper mouth and takes off the tuft of fibres; then changing its straight form into a curved

one, approaches the comb ring *A*, upon which it deposits the fibres, in nearly a horizontal position, withdrawing from there so as not to disturb the parallel position of the fibres, at the same time placing the fibre ends as far over the comb ring as to fulfil the above-named conditions.

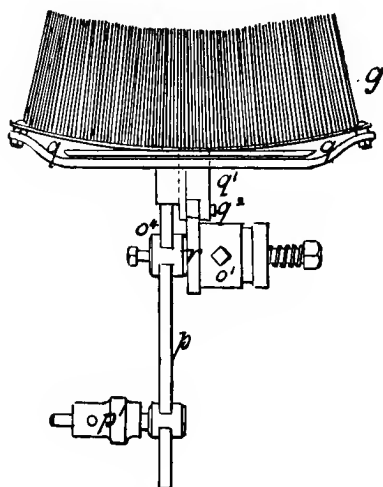

FIG. 28.—Another View of the Carrying Comb.

To regulate all these requirements, and to arrange them for different lengths of fibres, the connecting rod o^1 and the position of the bar p^1 are adjustable, and the two ends of the lever $o^2 o^3$ are movable in slots. The carrying comb receives its motion from the crank shaft o , driven from the nipper shaft h^4 by two equal spur wheels, the latter being driven from the main

shaft s by the two wheels s^1 and s^2 . The brush t , which serves to dab in the tuft of fibres into the teeth of the comb-ring A , receives its oscillating motion from the back screw shaft K , by means of the lever, b^1 , the adjustable bar, b^2 , the slotted lever b^3 , and the eccentric rod b^4 . To avoid entangling and lapping over of the fibres of the tufts laid into the comb ring, the projecting fringe is kept down by a current of air. The stroker D is in the shape of an endless band covered with small transversal bars. The form of the drawing-off rollers E , the tunnel v , and the pressure or balling rollers ww is already well known, and will be understood without further description. They are set in motion by the wheels w^1 to w^5 . For the lifting out of the noils, the noil knives x are used, which, working between the rows of teeth, raise up the noils and turn towards the noil rollers F (Fig 24). Their lifting motion is produced by the rod x^1 , the square lever x^2 , and the eccentric x^3 , the latter fixed upon the axis of the noil rollers, which are driven by the wheels a^{14} and a^9 . The tunnel v is put in rotary motion by the band v^1 and the stroker D by the band v^2 .

The above-described construction of the carrying comb with movable points is chiefly used for short and fine wools. For the long English wools a fixed curved shape (Fig. 31) is employed, which then necessitates the same same curve in the other correspond-

ing parts of the feed apparatus, the jaws of the nipper

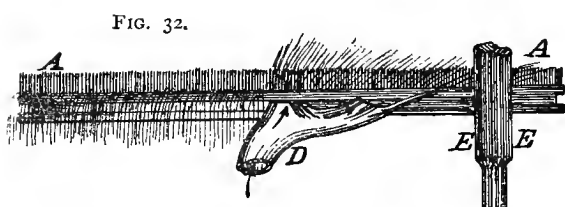
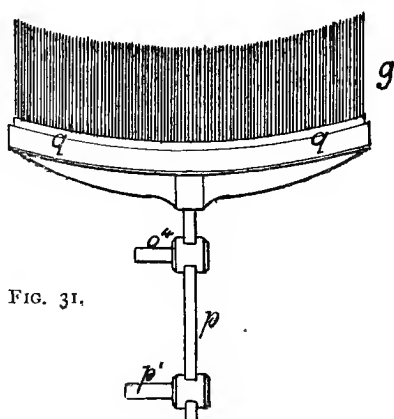
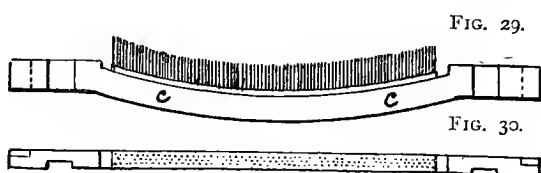

FIGS. 29-32.—Various kinds of Carrying Combs and Fallers.

and the fallers. Figs. 29 and 30 show a faller in that shape.

It would be impossible to apportion the individual share of Lister and of Donisthorpe in the machine we have just described. They acted in conjunction though all the more difficult stages of invention and the Nip machine as it stands to-day must be regarded as their joint invention. Up to a certain point Donisthorpe acted alone, and undoubtedly achieved highly important results, but when the stage of complete practicability was reached the two inventors were acting in close collaboration. Nevertheless, Mr. Lister has always shown the utmost generosity in speaking of his colleague's inventive efforts, in regard to this machine. In the speech from which we have previously quoted, he said, "Mr. Donisthorpe who worked with me has departed hence, and I think that full justice ought to be done to him: I took out a patent for the Nip machine, but though I did so, I feel I am not the inventor. . . really and truly Mr. Donisthorpe was the first to have the idea of combining the nip with the screw gill."

Mr. Donisthorpe had charge of the Nip machine which was exhibited in the machinery department of the Great Exhibition of 1851, and while there saw a great deal of the late Prince Consort, who evinced a most lively interest in the invention and acquainted himself with its movements and working. Some

years later, when the Prince Consort visited Leeds, his Royal Highness renewed his acquaintance with the combing machine, which was being shown at a local exhibition. Mr. Donisthorpe was there, and, after a hearty greeting, the Prince stopped to watch the operations of the machine, which was working splendidly. The story goes that the Prince, after a close inspection of the different parts of the machine, suddenly turned to Mr. Donisthorpe, and pointing to a particular part said, "I think, Mr. Donisthorpe, there is something wanting there." Mr. Donisthorpe was equal to the occasion, for he immediately replied, with a most gallant bearing, "None but a prince could have discovered the omission." It would be more satisfactory to know which special portion of the Nip machine owes its origin to the Prince Consort, but perhaps the spirit which dictated so courtier-like a remark as Mr. Donisthorpe has been credited with would also suggest the propriety of the observance of secrecy as to the something lacking that the Prince detected. We are safe, however, in drawing the conclusion that the shortcoming was not a very vital matter, seeing that at that time all the leading principles of the machine had been invented and put into operation. All the same, Mr. Donisthorpe acted with a tact and grace worthy of a great inventor.

For several years Mr. Lister was at the head of



G. E. DONISTHORPE.

woolcombing operations both in this country and on the Continent. He had nine combing-mills at work at the same time—five in England, three in France, and one in Germany. In 1856 he was in command of this entire branch of the worsted manufacture. His works at Manningham were greatly extended, and he had other establishments in Bradford, Halifax, Keighley, and other places in the West Riding. The ball of fortune was at his feet, and for a while he kept it rolling with splendid results. Wealth poured in upon him in an uninterrupted stream, until through the mismanagement of his lieutenants here and there he was led into mistakes and losses that ultimately caused him to relinquish his more distant undertakings and confine himself to those concerns to which he could give a more direct personal supervision. Then there came a time where his inventive aspirations took a different turn, and he took up the waste silk problem with the same energy and singleness of purpose that he had previously given to the woolcombing difficulty and with the same successful result. It took him and his co-workers ten years to carry out this stupendous achievement, and cost him 360,000*l.* but he accomplished all that he had set himself to perform and more, and is to-day at the head of one of the largest industrial establishments in the world, devoted mainly to the working up of waste silk.

After having once ventured upon this second phase of his distinguished commercial career, he ceased to retain his old position as the king of woolcombers, the trade fell into other hands, and the further improvements that were to be effected in the woolcombing machine were neither to be coupled with his name nor executed in his interest. His connection with machine woolcombing extended from 1842 to 1858, during which period he was almost continuously engaged in making or introducing improvements.

Mr. Donisthorpe did not cease to invent, even after his connection with Mr. Lister was finally severed. As is indicated in a later chapter, he was intimately concerned in the bringing forward of the Noble combing machine, and perhaps originated more improvements in mechanical methods of combing wool than any other inventor that this country has produced. To Mr. Lister the credit is due of having worked the earliest of Donisthorpe's inventions to the point of commercial success; still, it was Mr. Donisthorpe's ideas that served as the foundation upon which that first success was built. Mr. Donisthorpe possessed creative genius of a high order, and it is well that Bradford, while honouring other names that have been prominently associated with the development of its industries, should not forget one who accomplished so much

towards the extension of its prosperity. After the Noble combing machine had been well established in the trade, Mr. Donisthorpe entered into partnership with Mr. John Croft at Larchfield Mills, Hunslet, and for many years carried on a successful business there. In his later years he was interested in the invention of coal-cutting machines. He died on the 13th of January 1875 at his residence, Belvedere House, Harrogate.

CHAPTER XI.

ISAAC HOLDEN.

It is necessary now to take up a thread of wool-combing history which will bring us abreast with the existing condition of this industry. The thread is a long one, it is true, and at points overlaps other threads with which we have been concerned; nevertheless, it takes us by a fairly direct course from the handcombing period down to the perfection of machine-combing as it is so successfully prosecuted at the present day. We must go back to the autumn of 1830 for our starting point, when a young man, fresh from scholastic pursuits, but with a strong inclination towards industrial life, was accidentally brought into touch with the efforts that were being made to master the difficulties of the woolcombing machine, which remained at that time much as Cartwright had left it at the beginning of the century. This young man was Mr. Isaac Holden, who was destined later on to play a very important part in the

development of a particular phase of machine wool-combing.

The career of Isaac Holden up to this period had been one of struggle and hardship. From childhood to manhood he had fought his way bravely through adverse circumstances, and by energy and force of character had worked himself up from poverty and the humblest form of toil to a position which, if still of no great consequence, was sufficient as an opening to a more prominent sphere of usefulness.

Born on the 7th of May, 1807, at Hurlet, a small village between Paisley and Glasgow—his father then holding the post of headsman at the Wellington pit, Nitshill—he saw much in his early years of the privations and distress to which the labouring community were doomed by the long war with France, which had almost drained the country of its resources, and brought commercial enterprise to a point of stagnation. Employment in those days was hard to obtain, and the poor workman was buffeted from pillar to post, and had to shift from place to place, seldom able to keep a situation for long together. Isaac Holden, however, was fortunate in having for his parents a respectable, industrious couple, of earnest piety and sturdy principles, who, though beset by trials before which many would have

succumbed, contrived so to order their lives and govern their family that the pressure of poverty was not able to crush or deteriorate the high personal qualities of the race. The father was a native of Alston, in Cumberland, where he had originally combined the occupations of farmer and lead-miner, but in 1801, the mines having become exhausted, he was compelled to go further afield in search of a livelihood, and settled in the neighbourhood of Glasgow. His wife belonged to an old Scotch family of the name of Forrest. This worthy couple spared no effort in promoting the material and spiritual condition of their family and surroundings, and, considering the influences in operation against them, accomplished wonders. The husband established a night-school in the village, and devoted his brief leisure-hours to the teaching of his neighbours' children—a duty which he was proud to assume and which he performed without fee or reward. Furthermore, the family were active participants in the religious movement which John Wesley originated and carried forward with such remarkable results.

Such were the exemplary influences under which young Isaac Holden was trained until he reached his tenth year, when the necessity of obtaining fresh employment forced the father to remove to Kilbarchan, about nine miles distant from Nitshill. Up to this

time Isaac had been fortunate enough to be kept at school, and even after the removal to Kilbarchan he was sent for a few months to the grammar-school of that town. But young as he was, the lad had a strong leaning towards industrial pursuits, and when he engaged himself to two hand-weavers in the neighbourhood as "draw-boy," for a small weekly wage his father, on the understanding that he should continue his education at a local night-school, reluctantly allowed him to accept the situation. This arrangement continued for two years, at the end of which time the father secured more remunerative employment for himself at the village of Johnstone, and the transfer of the household from Kilbarchan to Johnstone brought the youth's service as "draw-boy" to a close.

It was intended that Isaac should now resume his more regular scholastic studies, and for a short time he went to a day school at Johnstone; but, having once experienced the delights, responsibilities and independence of labour, he longed to return to it, and soon afterwards went to work in a cotton mill. This was much against the father's desire, his solicitude for the lad's education being always uppermost, so Isaac was again compelled to relinquish his employment, and was placed under Mr. John Fraser, a very able and zealous teacher who was known as the Old Radical, and from whom

doubtless Mr. Holden imbibed advanced political opinions as well as knowledge of the higher branches of study which formed a portion of Mr. Fraser's curriculum. After a twelvemonth's course with Mr. Fraser, Isaac Holden returned to the cotton factory as a "piecer," and was permitted to remain for a rather longer term than previously; but after a time he was again emancipated from his duties at the spinning-frame, and resumed his old place at Mr. Fraser's school, continuing there until he was fifteen years of age. Thus, it will be seen, Isaac Holden, while making himself proficient in scholarly acquirements, also kept himself practically acquainted with the condition of manufactures, and was able to lay the foundations of that industrial career in which he was afterwards to distinguish himself.

It then became necessary to decide upon a calling for the lad, and he was bound apprentice to an uncle at Paisley to learn the trade of shawl-weaving. For a year or so all went well, and it looked as if Isaac Holden was about to settle down for a while to the loom; but his health gave way under the physical exertion of the occupation, and it was then determined that he should adopt the profession of teaching, for which he had evinced considerable aptitude. Accordingly, he obtained a position in the scholastic establishment presided over by Mr. John Kennedy, a noted educationist,

mathematician, and lecturer, and while acting as Mr. Kennedy's assistant he found opportunities for prosecuting his own studies in the higher branches of knowledge, receiving private lessons from his master in mathematics, physics, Latin, Greek, &c. Little by little his position improved, and when, in 1826, his father died, and Isaac found his mother and a younger brother dependent upon him, it was fortunate that he was able to provide for them without having to relinquish his school duties. He remained with Mr. Kennedy until 1828, and being then in his 21st year, and having sufficient confidence in his own powers to warrant the step, he quitted home and country, and accepted the post of mathematical teacher at the Queen Square Academy, Leeds. After that he was for a time English and commercial master at Lingard's grammar school at Slaithwaite, near Huddersfield. Then he ventured further south, and became classical tutor at the Castle Street Academy, Reading, at which institution he found a wider scope for his talents than he had previously enjoyed. He taught Latin and Greek to the advanced pupils, and had several French classes under his charge. He had acquired French at Paisley, in the first instance, from the Rev. John Hick, a Wesleyan minister from Canada, and having continued the study of the language, found it, then as well as subsequently, of the greatest use to him.

Mr. Holden prospered so well at the Reading Academy that by the end of the first term he had established a course of lectures on science and history, which he delivered on Wednesdays and Saturdays to about a hundred youths. He also gave lectures on chemistry, and, at his suggestion, a chemical laboratory was started, where from time to time he illustrated his teaching by practical experiments.

It was while engaged in these studies that Mr. Holden chanced upon a discovery that proved to be of great public value, and which might have yielded him a high pecuniary reward had he turned it to proper account. This was the discovery of the principle of the lucifer match. Up to that time the tutor had hardly given a thought to matters of invention, much less to the subject of patents, or this idea of the lucifer match might have been identified with his name. Long afterwards, when Mr. Holden had become renowned amongst inventors, and was called upon to give evidence before a Select Committee of the House of Commons, appointed to inquire into the working of the patent laws, he made an interesting reference to this incident in his early career. Having been asked for his testimony rather unexpectedly, without having had time to prepare general evidence in support of his opinions, he was only able to make brief references to such of his own personal experiences as would

illustrate his argument, which was, that patents are useful and for the public good when granted for inventions requiring much and long thought, and involving great expense in the experiments necessary in order to mature them, and that protection might be safely withheld from such inventions as called forth such little thought or cost as attended his small invention of the lucifer match. "I began as an inventor on a very small scale," said Mr. Holden. "For what I know, I was the first inventor of the lucifer match; but it was the result of a happy thought. In the morning I used to get up at four o'clock in order to pursue my studies, and I used at that time the flint and steel, in the use of which I found very great inconvenience. I gave lectures in chemistry at the time at a large academy. Of course I knew, as other chemists did, the explosive material that was necessary in order to produce instantaneous light; but it was very difficult to obtain a light on wood by that explosive material, and the idea occurred to me to put sulphur under the explosive mixture. I did that, and published it in my next lecture, and showed it. There was a young man in the room whose father was a chemist in London, and he immediately wrote to his father about it, and shortly afterwards lucifer matches were issued to the world. I believe that was the first occasion that we had the

present lucifer match, and it was one of those inventions that some people think ought not to be protected by a patent. I think that if all inventions were like that, or if we could distinguish one from the other, the principle might hold good. If all inventions were ascertained and carried out into practice with as much facility as in this case, no one would perhaps think of taking out a patent. I was urged to go and take out a patent immediately ; but I thought it was so small a matter, and it cost me so little labour, that I did not think it proper to go and get a patent, otherwise I have no doubt it would have been very profitable." As an antithesis to this, and in further establishment of his theory, he proceeded to explain how his later inventions connected with the wool-combing machine had involved immense labour, thought and expense, and that these therefore were of the kind that no inventor would undertake unless he had a prospect of reaping the commensurate reward which patent-right alone could give him.

Mr. Holden remained at the Reading academy for eighteen months, which for that period provided him with a happy home and a sphere of useful activity. As yet it was uncertain how he would shape his career. He had a strong hankering after a life of religious ministration, his training having been such as to favour devotional thoughts and yearnings ; indeed at one time

he had all but completed arrangements for entering the Wesleyan ministry. Occasionally, however, his mind would revert to the field of industrial enterprise, and as he read the accounts of the marvellous developments which invention was working out in this direction he was fired with an intense longing to take part in the great mechanical achievements that were going forward. But it was for the ministry that he would have decided, nevertheless, had it not happened that his health broke down again, compelling him to return to his home in Scotland, and for a while to abandon all engagements. His native air and the affectionate care of his mother restored him to health, and taking advantage of an offer made by a Glasgow friend, who built a school for him, he shortly afterwards found himself occupying the position of a Scotch dominie, and, to all appearance, settled down for life. But this was not to be his destiny. Before he had been installed in his new school six months, a circumstance occurred which changed the whole tenour of his life and took him away for ever from the work of teaching.

In November, 1830, Mr. William Townend, a member of the firm of Townend Brothers, of Cullingworth, near Bingley, was in Glasgow on business, and happening to mention to a local gentleman that he was in want of a book-keeper, was recommended to see Mr. Holden. He did so, and was so favourably

impressed by the young schoolmaster that he offered him the place there and then. There could be no question as to Mr. Holden's eagerness to accept a position so pregnant with opportunities, and had there been only his own inclination to consider he would have immediately closed with Mr. Townend. But there were ties of home and kindred to be thought of, and there had to be taken into account a hardly less binding tie of gratitude to the friend who had built and established the school for him. Mr. Holden asked for a day to deliberate, and having obtained the consent and approval of his mother and friend to the step, was able the next day to announce to Mr. Townend that he was ready to follow him to Cullingworth. Within a week from that time the furniture and good-will of the school had been sold to an old pedagogue in the neighbourhood, and Mr. Holden was on his way to Yorkshire, to a new life and new prospects ; but he never faltered or hesitated when once he had made up his mind it was the right course to take ; and when, on a dull November day in 1830, he landed in the picturesque loneliness of Cullingworth, and was introduced to the factory where he was destined to labour lovingly for many years to come, amidst wheels and spindles and looms, he had not the least misgiving as to his fitness for the fresh mode of existence that was opening out to him.

This was the flood-tide in Mr. Holden's affairs. He

took it, and it led "on to fortune." But it was to be no sudden leaping into wealth, no achievement of high rewards at a bound. Before him lay years and years of patient toil and unceasing effort. All this he accepted and admitted, but he had courage to undertake the task, and faith in the good result. Dreams of riches did not trouble him, however, for, as far as mere worldly resources went, he had but very moderate desires. What he longed for, first and foremost, was an adequate sphere of usefulness, and this he certainly found—at least for a time—at Cullingworth. The opportunity was afforded him of devoting his full energy and ability to industrial work. He found himself in a congenial atmosphere, where his intelligence, perseverance, and untiring diligence could be successfully exerted.

Cullingworth was then an old-world region, away from the busy business centres, but still within easy reach of them, as things went in those pre-railway days, being only a few miles distant from Bradford, the head-quarters of the worsted manufacture, with which Messrs. Townend were connected. It was a country district, inhabited by a community of good-hearted Yorkshire dalesmen, and perched high among the same moorland hills upon which Charlotte Brontë was accustomed to look out, a few years later, from the lonely Haworth parsonage where she wrote her

remarkable books. At first it must have seemed a curious notion, and a risky enterprise, to plant a factory out in this remote corner of the world; but the Townends were men of "grit" and energy, and they succeeded in establishing there an extensive manufacturing concern, and in gathering round them a prosperous hard-working community.

It was a favourable time for entering upon fresh projects and undertakings. The worsted trade was in the first flush of expansion and development; machinery was just beginning to assert its power in this branch of industry, as it had already done in the cotton manufacture; and to a young man like Mr. Holden, in the full vigour of youth and hope and high purpose, the prospect must have been very inspiring.

At first Mr. Holden's duties did not extend beyond the counting-house. He had been engaged to fill the office of book-keeper, and for the first year of his service at Cullingworth he acted in that capacity exclusively. But it was soon perceived that the mill was his proper sphere. He had gradually been drawn to inspect and examine the machinery, in the working of which he displayed a lively and intelligent interest. From time to time he made suggestions for the improvement of various mechanical details, and so impressed were his employers by his skill in this

direction that they ultimately made him manager, and, later on, partner. It was now evident that Mr. Holden had settled into the industrial groove in which he was thenceforth to continue. In 1832 he took a further step towards fixing his career by marrying. His wife was Marion, the eldest daughter of Mr. Angus Love, of Paisley. This estimable lady, to whom he had been engaged six years, proved a valuable helpmeet to the inventor, and by her womanly heart and excellent example won the esteem of all who knew her.

It was as an inventor that Mr. Holden resolved to ultimately employ his abilities. Nor was he long in determining what particular branch of invention he would concentrate his energies upon. Shortly after his arrival at Cullingworth, Mr. Robert Townend took him to a woolcomber's cottage in the village, where for the first time he saw the manual operation of wool-combing being performed. Mr. Holden was keenly interested in what he saw, and asked if the work had never been attempted to be accomplished by machinery. The reply was that there had been experiments innumerable, but that no one had thoroughly succeeded, the fibre being of such a delicate nature, and so difficult of treatment, that it was hardly considered possible to adapt machinery to all the requirements of the operation. Mr. Holden was too modest to assert his

belief that the feat was within the reach of human effort, in the presence of a man of such wide experience as Mr. Townend; nevertheless, he so far settled the matter in his own mind that he resolved to devote himself to the task of inventing such a machine. From that day forward he never ceased to engage his thoughts with woolcombing, although it was not until some time afterwards that circumstances favoured his ideas being put to any practical test. How earnestly he applied his mind to the work of the factory may be gathered from the fact that he was always at his post by six o'clock in the morning, and seldom relinquished his labours before ten at night. Only on two or three occasions during the fifteen years that he remained at Cullingworth did he indulge himself with a holiday. His heart was so completely in his work that he found little pleasure away from it.

When the woolcombing problem first confronted him, he made it his duty to acquire a thorough knowledge of all that had been done by previous and contemporary inventors towards mastering the difficulty. That being done, he set himself to think out his own methods of dealing with the question. He was much assisted in this by the action of Messrs. Townend, who, in 1833, at his suggestion, bought seven combing machines on the principle patented by

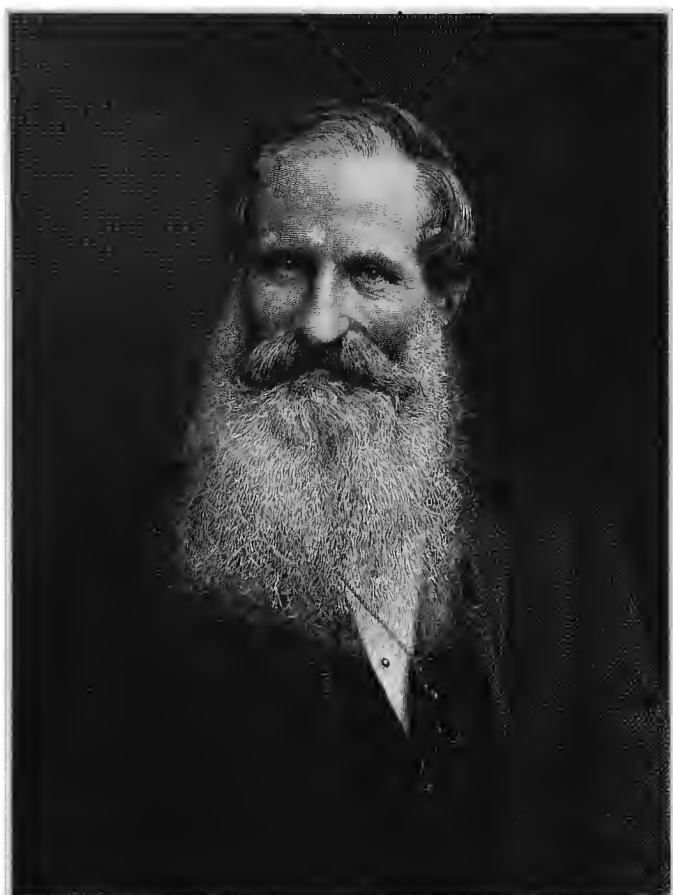

Isaac Holden, M.P.

Collier. It was found that these machines were very imperfect, and quite supported Mr. Robert Townend's assertion that it was impossible to comb wool properly by mechanical means. For a while Mr. George Townend, the senior partner, had the charge of the Collier combing machines, but he gave them up in disgust after a three years' struggle to make them profitable, and handed them over to Mr. Holden. This gave Mr. Holden the opportunity he had been so long waiting for. He at once began to experiment with them, and in a short time added such improvements as enabled them to be worked to advantage. Collier's machine, as we have already shown, was an invention of considerable merit, and a marked advance upon previous combing machines, but it was defective in its working. As altered by Mr. Holden, however, the seven Collier machines continued to be used by Messrs. Townend with good results on certain wools as long as he remained connected with the firm.

One of the improvements then worked out Mr. Holden considers is one of the simplest and most effective inventions of his life. In consequence of these successful experiments, and of the introduction by Mr. Holden of important improvements in the making of heald and genappe yarns, of which Messrs. Townend were then the largest makers in England, he was

appointed general manager of the works, with a small share of profits, and continued to fill this post down to the beginning of 1846.

We have been permitted to refer to certain manuscript "Retrospective Notes," penned by Mr. Holden in 1879, a quotation from which will serve to show the course of his inventive efforts at this period. "After seeing Henry Ross's machine," he writes, "patented in 1838, with drawing-off rollers, drawing first the long, then the shorter wool, I planned a horizontal circular comb with filling on and drawing off motions, and working at different parts of the circle. I was mortified when I found some time after this that Mr. G. E. Donisthorpe took a patent (in 1842) for this very form of machine. His modes of filling, working, and drawing off were very rude, but at a later period he improved the filling and working so as to make it practicable, with the use of Ross's drawing rollers. The only faulty part was the working combs, for which I had provided a remedy, as before referred to. Soon after, an improved means was found for this, and patented by Mr. Ramsbotham in 1846—the screw gill working comb. Its main fault—which I could not fail to see—was that the comb was pushed away too slowly by the screw after it entered the beard close to the circular comb head. The consequence was that the comb was locked in the beard

if it entered it near the comb head, and, therefore, to avoid this it was necessary to strike into it at some distance, and even then to use coarse and strong combs. The result was bad combing. This evil I felt certain would be avoided by the mode of working I conceived of—the Square Motion, viz., striking a fine comb into the beard *near to the comb head, and at once pushing it away from it to avoid locking.* The whole secret of the invention lay in this discovery, the necessity of pushing away quickly, so simple at first sight, but difficult to conceive and appreciate at that early period; and though so apparently simple it was the result of much continued thought. This point being seen, the mechanical arrangement to do it was easy of application by cam or tappet by any ordinary mechanic, as is evident by the numerous modes of doing it which I afterwards patented.”

Mr. Holden, like Cartwright and other inventors, was impressed with the idea that the machine which was ultimately to accomplish perfect combing would have to imitate as closely as possible the varying movements of the handcomber. From this belief he never swerved, and in all that he has done from that time to this in the way of improving woolcombing machinery, he has kept that end in sight. But it was not at Cullingworth that Mr. Holden could hope to find full scope for his inventive

schemes. Messrs. Townend had had too much trouble with the Collier machines to be eager to associate themselves with any further woolcombing experiments, which must necessarily be costly and hazardous, so Mr. Holden made up his mind to carry his ideas to a more likely market. Several other inventors had come to the front in connection with the wool-combing machine, while Mr. Holden had been quietly applying himself to its study in the solitude of Cullingworth. Important patents had been taken out by Mr. Donisthorpe, Mr. Ramsbotham, and others, and the trade were gradually awakening to the belief that a machine capable of combing wool as well as it could be combed by hand was looming in the immediate future. Indeed before Mr. Holden was able to loose himself from his Cullingworth moorings, and throw his energies into the work completely, Mr. Lister had, in conjunction with Mr. Donisthorpe, as we have seen, brought a machine into operation, which, with improvements afterwards patented, was largely bought, and yielded Mr. Lister a handsome fortune.

In 1846 Mr. Holden removed to Bradford, the chief centre of woolcombing operations, and where there was yet a considerable community engaged in the arduous and ill-paid labour of handcombing. At

first Mr. Holden was engaged in working out some plans of making heald and genappe yarns ; but ultimately he took his place amongst the prominent workers in the woolcombing problem, and became associated with Mr. Lister as an inventor.

CHAPTER XII.

THE INTRODUCTION OF THE SQUARE MOTION PRINCIPLE.

WE now come upon a time of great activity in woolcombing invention. It had been clearly demonstrated that the work of the handcomber could be performed by machinery. The question was, which of the many inventors then engaged in grappling with the difficulties that remained would be the first to surmount them. Mr. Donisthorpe had mastered some of the perplexities involved in the problem ; Mr. Lister had contributed materially to the practical application of the idea ; Heilmann was devoting his full energies to the task in Alsace ; and Mr. Holden's mind had become so absorbed in the development of this mechanical revolution that he ultimately abandoned all other enterprises that he might take part in it. It was a neck to neck race of inventors for a magnificent prize. It meant a splendid fortune to the one who should win it. No wonder that so many men were tempted to press into the contest. But the remarkable

thing about this struggle was that nearly all the competitors who took prominent part in it achieved the honours of victory. It was not left for any single individual to claim all the credit, or all the reward, for the attainment of practical success. Results of fairly perfect working were realized by Donisthorpe and Lister in one direction; by Heilmann on similar lines to theirs, but by an independent creative effort; and by Lister and Holden in connection with the particular principle with which Mr. Holden's name now stands identified—the Square Motion.

In October, 1847, the names of S. C. Lister and Isaac Holden make their first appearance in conjunction on the records of the Patent Office, when a patent was taken out by them for a number of minor improvements in carding and combing wool, including a mode of filling wool on to combs and drawing it off without working with other combs, a method of using moveable combs, a system of drawing wool off combs, an arrangement of combs to be used with circular or endless combs, and a plan of packing the chambers formed between the separate rows of teeth of combs, thereby producing false comb-heads.

The alliance thus formed between Mr. Lister and Mr. Holden was found to be of mutual advantage, and the two inventors were thrown much together during the next twelve months, interchanging ideas, comparing

notes, and occupying themselves almost exclusively in attempts to improve the woolcombing machine. On the strength of the prospect of success held out by this unity of action, a closer link of connection was forged, and in October, 1848, the two entered into partnership in the woolcombing business, with a special view of setting up an establishment in France, where it was thought there was a profitable field for the employment of the improved combing machinery of which they had the control. Thus the French firm of Lister and Holden came to be formed, and Mr. Holden went over to Paris to make arrangements for commencing operations. It was a matter of considerable difficulty to decide upon a suitable place for the erection of their machinery. Indeed, it was a time when political troubles cast their shadow upon all human affairs, and it needed no little courage, and an abundance of confidence, to embark upon a serious business enterprise in the face of so many disturbing surroundings. The task would have been too serious for one man to have undertaken alone, but Mr. Lister, who was already so largely engaged in this business in England, secured in Mr. Holden a worthy and competent coadjutor, well able to prosecute their joint enterprise, as subsequent events amply proved. After careful inspection and deliberation, a factory at St. Denis was at last pitched upon as answering all require-

ments, and there in due course the first of Lister and Holden's woolcombing machines were put in operation. There was already on the same premises a woolcombing concern on Collier's system, conducted by MM. Bernier and Fils, the commercial department of which was under the direction of Madame Bernier, it being customary in those days for ladies to manage the financial affairs of a business undertaking. There seemed to be something more than coincidence in the fact that the portion of the factory occupied by Messrs. Lister and Holden had just previously been tenanted by Madame Collier as a shop for the construction of Collier's combing machines. Up to that time woolcombing in France had been mainly done by peasant farmers at their own homes, as it had been done in England by the handcomber. The work was scattered far and wide over the country, being managed by agents in the various localities, who delivered the raw wool to the combers, and collected it when combed, at a certain commission. The combs they used were rude instruments with steel teeth, some eight inches long and an eighth of an inch in diameter, and the work they did was so imperfect that the wool required picking in all the stages of spinning and manufacturing. The handcomber of France was far ahead of his brother-artisan in England in some respects; as he enjoyed some advantages that were unknown to the English

workman. Being a peasant proprietor he only took up woolcombing as a supplementary occupation, to be followed when the weather was unfavourable, or during the winter time, when it was useless to think of working in the fields; the English handcomber, on the other hand, was solely dependent on his one employment.

At St. Denis, Lister and Holden began operations with Donisthorpe and Lister's machine as it was then used at Manningham Mills, Bradford; but the working or lashing combs were at once found to be unsuitable for fine wools. Shortly after starting, the first Square Motion machine introduced to France arrived from Bradford, but it was found to be so imperfect in all its parts and combinations that it was quite useless; in fact with the least load of wool on the circle comb it was quite impossible to work it, and in spite of all efforts, it had at length to be put aside, and was to all appearance forgotten. For the next year or two the only machine used by Messrs. Lister and Holden in France consisted simply of the circle and drawing-off rollers and Donisthorpe's filling heads, without any cleaning apparatus to the beard of wool on the circle. This necessitated two operations upon the same machine, usually called jigging and straightening, as was done in handcombing. This method of donning on the circle comb and drawing-off

without any working apparatus was most unsatisfactory, leaving the 'tops' knotty and being unsuitable for the spinner. So, after a while, the discarded Square Motion was taken in hand again, and, after many experiments and the introduction of important changes and modifications, it was got to work. By this means the combing of wool was completed in one operation, and another important addition was made to the Cartwright principle, in imitation of the work of the handcomber.

The first patent in which the Square Motion principle was brought forward was dated the 19th of October, 1848, about the time of the signing of the Lister and Holden deed of partnership. Much discussion has arisen upon the origin of the idea of the Square Motion, Mr. Holden claiming the paternity of it, although the patent was taken out in Mr. Lister's name alone. Of course this first Square Motion patent did not represent the full application of the principle and the successful working of it; the main merit of the utilization of the idea belongs to the improvements of which later patents have been the subject.

The Square Motion, as explained in the specification, represents a mode of action similar to that of the Screw Gill, except that the screw is dispensed with. All that is required, it is stated, is to attach a suitable pair of feed rollers, and also another pair of rollers to the

wool from the comb bars, and in feeding the wool to give a draught of two or three, and the same in drawing

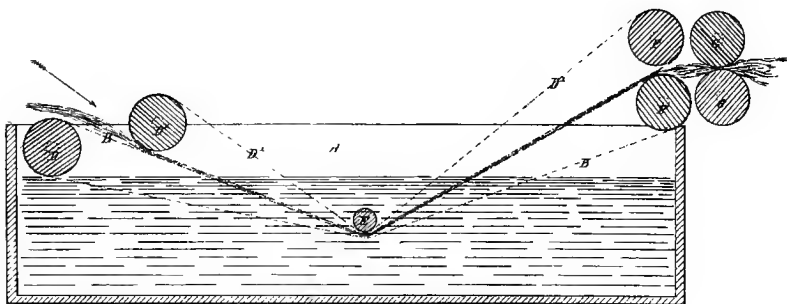

FIG. 33.—Washing Trough.

off. The teeth, it was added, ought to be from one to two inches in length. Mr. Lister's specification illus-

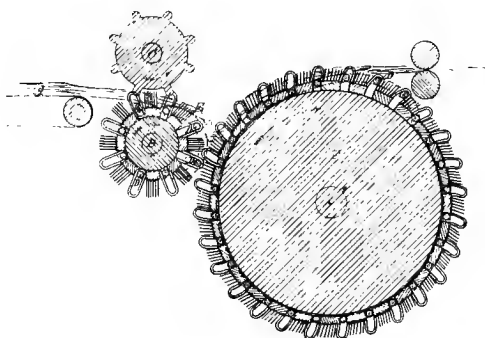

FIG. 34.—Feed Rollers.

trates by Figs. 35, 36, and 37, and explanatory descriptive references thereto, that the object of the invention is to

save the labour attendant upon moveable combs by substituting fixed combs that deliver wool which they rob from the carrying combs, without the trouble and labour of being removed to have the wool drawn from

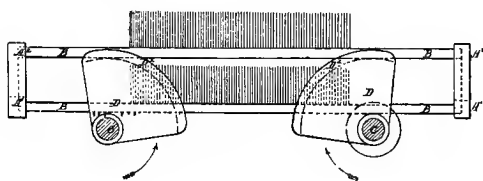

FIG. 35.—End view of Combs.

them. The bar combs B move in races, A^1 and A^2 , and motion being given to the shafts c , upon which the cams D are placed, these cams D , as they revolve, lift the bar combs from the lower races A^1 to the upper

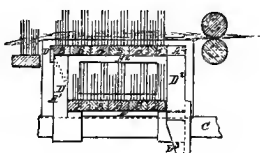

FIG. 36.

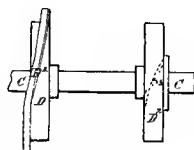

FIG. 37.

guides or races A^2 , and at the same time cause the combs so raised to penetrate through the wool. As soon as the combs B are lifted to the upper races, the *inclines* D^1 on the face of the cams D (which

are really threads of a screw), as the cams D move round, push against the side of the bar comb B , which has just been raised, and force it, with all the other bar combs in the races A^2 to travel a distance equal to the width of one of the bar combs. At the other end of the races A^2 are similar cams D^2 , which receive the combs as they are pushed forward ; and as these cams D^2 revolve they allow the bar combs to descend again by their own gravity to the lower race A^1 , when the inclined surfaces D^3 (in the revolution of the shafts c) push them forward in the same manner as the bars in the upper race. The front cams D , being under the combs so pushed forward as they revolve, again lift them into the upper race, and force the teeth of the bar comb through the wool in the holding comb, thereby combing and clearing it from trash and noil, which is drawn from the bar combs by rollers or other suitable means not indicated.

The teeth of the combs set in bars actuated by the inclines on the cams after the nature of *partial screws*, enter the fibrous material at right angles, and travelling through it in a horizontal plane, or nearly so, comb it out. It may be observed that the partial screws, being the pushing means, seem not in harmony with the claim of the patent—"similar to the working of a screw gill but without screws."

It does not appear that any working machine was

constructed according to this specification. In fact the square motion principle was little more than shadowed forth in that document; it required much additional inventive effort to bring it to the stage of practicability.

From about 1846 the tendency has been towards the use of finer teeth for the combs. Whereas teeth that formerly were as coarse as four or eight to the inch and as long as six or more inches, teeth are now used as fine as forty to the inch and as short as $\frac{3}{4}$ in. This increased fineness of teeth and closeness of grade necessitated provision—especially in the Square Motion combing machine—for avoidance of locking of the fibres in the operation of drawing the square motion away from the circle combs instantaneously upon the insertion, and it was in this respect that the greatest difficulty attended the primitive square motion machinery.

In the earlier attempts to produce a practicable Square Motion combing machine, the two essential features of success, viz., 1st, the entry of the teeth of the square motion combs into the beard or fringe of fibres of wool close up to the teeth of the circular comb in which they were held; and 2nd, the *instantaneous* retrocession of the teeth so inserted from the travelling teeth of the circular comb before the locking of the two sets of teeth together could take place, were not

sufficiently met. This locking of the teeth was liable to happen because the teeth of the circular comb, with one end of each fibre to be combed held in them, are travelling round the centre, whilst the square motion comb teeth rise up into the fibres as, relatively to the circle's motion, at a standstill. Hence this relative standstill must be reduced to a minimum to avoid jamming. This is done by causing the square motion teeth to be pushed from the circle teeth as rapidly as possible, as soon as they have so entered the beard.

Lister's patent of 1848 attempted to attain this combing by entering the teeth of the working combs into the beard of the fibres, and causing the working combs to recede from the circle teeth by means of a screw thread on the faces of cams, acting to force back the working comb bars, one after another, as they enter the wool projecting from the circle at right angles to the line of draught, similarly in mode of working to the screw gill.

The drawings in the specification of 1848, and the fact that the invention failed to accomplish its work as then devised, tend to show that the arrangement of the working and circle combs was impracticably carried out. The working combs, as shown by the drawing, did not enter close up to the circle comb, into the beard of the fibre, and did not effect the quick retirement of the working combs,

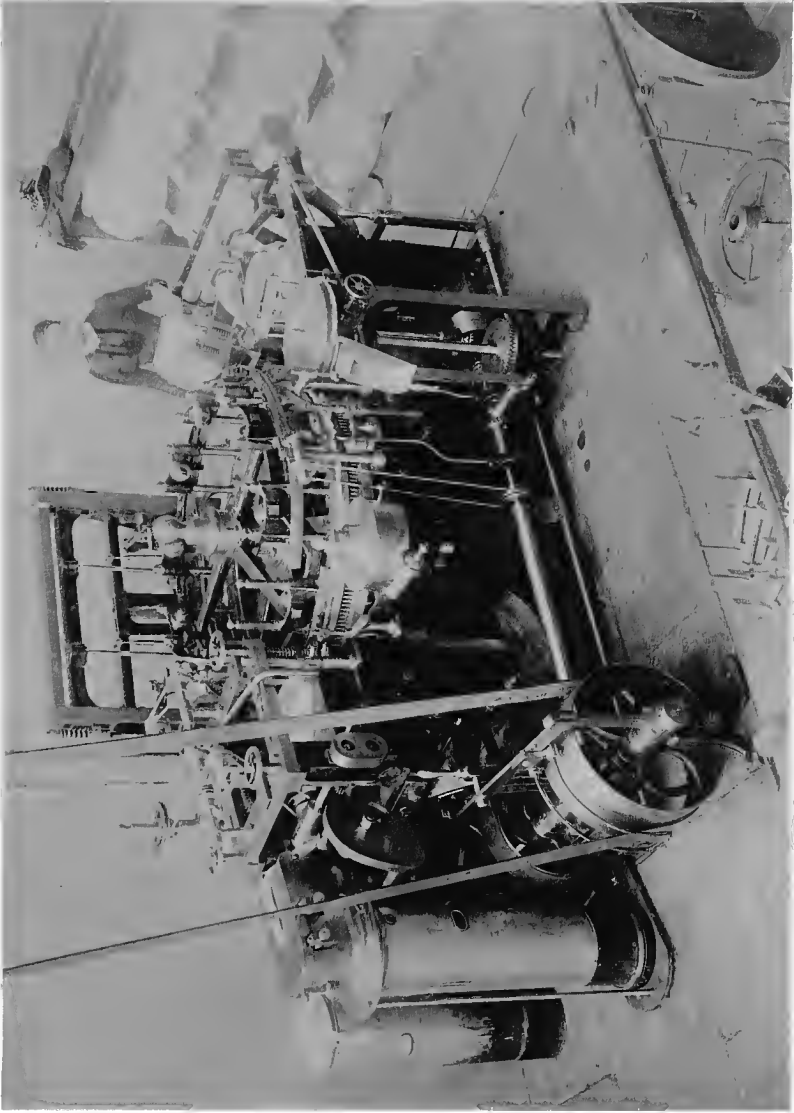

GENERAL VIEW OF THE SQUARE MOTION WOOLCOMBING MACHINE.

Considerable space (in fact about 2 inches as shown) necessarily was left between the working combs and the travelling circle comb, for the cams to enter, and the nature of the operative agency for retirement prevented instantaneous action to disengage the teeth of the working comb before locking or jamming could take place with the fibre. There was no keeping plate shown. In the combed wool any space left between the points where the comb circle held the fibre and where the working comb points enter would be left foul and uncleansed of noil.

By successive improvements the Square Motion combing machine was gradually brought to its present perfection of arrangement and working power. Taking the imperfect machinery in hand as it was primitively designed—imperfect and inefficient for its purpose as it existed on its first introduction in 1849—the following changes were effected: The fineness of the teeth of the working combs was still further increased and they were set more closely together, as many as seventeen to thirty, or even more teeth being set per lineal inch in each row; and the length of the teeth was reduced to about one inch, more or less, the fine teeth, or especially the front rows, being made flat, so as better to resist the strain of the wool, which was found to be very great. Further, by applying steam or other heat to the working combs of the square

motion system, when in the lower race, where each comb rests for a short time on a steam chest; and, lastly, but of prime importance, the working comb teeth were made to strike into the wool close up to the circle teeth. These earlier improvements on the primitive Square Motion combing machine were patented in France Nov. 21st, 1851.

There is no doubt that at the first introduction of the Square Motion machine, in 1849, it was so imperfect that it could not have continued in existence more than a year or two as it was, and certainly it had not the slightest chance of competing with the Heilmann, or with Donisthorpe and Lister's Nip machine, which were coming into use at that time, but for the peculiar character of its work, as they produced top freer from knots and other imperfections. But successive improvements (hereinafter described), which were introduced from time to time, made it in a few years equal in all respects, and superior in several, to the machines previously named.

About 1850 and onwards, in the first Square Motion combing machines, the pins of the combs were 2 inches long and had eight pins to the lineal inch, four rows of pins in combs 2 inches broad. It was soon found that the proper square motion quick push that had been devised admitted of the use of finer teeth to these combs, and there were inserted as many as thirty pins

per lineal inch, and their length was reduced to as little as one inch. These changes were gradual, and made as experiment and experience taught.

In September, 1853, Mr. Holden patented in France a "double keeping plate," embracing the teeth of the circle, with up and down motion, also small fluted rollers for feeding and delivery.

In 1856, 5th May, No. 1058, a patent was taken out for England for "improvements in combing," &c., embodying the inventions put to work without being patented some years previously in France, and in this patented machinery were embodied means for effecting the movements of the working of gill comb bars by lifting and lowering frames actuated by cams or tappets. The frames extended downwards so as to be readily acted upon by cams at the lower part of the framing, by which means larger cams with more extended wearing surface could be employed. The requisite motion to the pushers of the working comb bars by the action of these cams enabled the movements of the bars to be better governed, as well as to be steadily held between the motions. Another important matter provided for, was the guiding of the bars in their rising and falling motions, and the holding of them after each rise and fall by suitable guides. These additions rendered a further improvement possible, viz., the making thinner

of the bars, thereby getting the consecutive rows of teeth in a series of bars closer together.

The importance of the improvements embodied in this patent cannot be realized without a fuller description. They related 1st, to means for effecting the movements of the comb bars. Hitherto, for the most part, such bars had progressive motion given to them by screws, and lifting and falling motions by cams acting immediately upon such bars. Progressive motion had been imparted to such bars by pushers, without screws. The improvements consisted in employing lifting and lowering bars with arms dependent, acted on by cams at the lower part of the framing, so as to enable larger cams to be employed with more extended wearing surface thereto. Also, further, in giving motion to the levers by cams, so as better to govern the movements to the bars as well as to hold them steadily between the motions. Also the use of guides to the guide bars, to guide their rising and falling, and retain them after each rise and fall, enabling the comb bars to be formed much thinner and thereby to get the consecutive rows of teeth in a series of bars closer together. The ends of the bars were formed much deeper than was usual, rising to the height of the gill teeth. The keeping plate for holding the fibre from escaping from the travelling combs while being worked was introduced to prevent choking; and brush card or toothed surfaces

upon the rollers for doffing combs adopted, sometimes using a stationary doffing plate; also an extra pair of rollers before and close to the horizontal fluted drawing-off rollers to draw the sliver from the travelling comb.

By the new system of operating the gill bars an intermittent action was obtained, and when feeding each comb rested with its tuft projecting as it fed, each tuft whilst between the last gill comb and a nip bar was acted on, first by a clearing comb to detach noil, &c., before detachment by the nipping instrument, and then taking the fibre from this nipping instrument that had drawn it from the gills, laying it on to a porcupine roller, rotating in a direction such that its teeth in taking fibre moved down from the porter comb, presenting the tail ends of the tufts to the drawing rollers, aiding this operation by a current of air, thus avoiding need of further combing, and after the upper nipping bar operated the small comb entered the beard close up to the last falling gill comb just before the nippers detached the cleaned tuft. Double or duplicate nipping apparatus acted successively on each tuft in detaching portions of fibres from the feed. Rollers and guides were used as feeding means when nipping apparatus was used as the fibre detaching means, independently of gill teeth but aided by jaws, effecting the detachment of tufts by the movement apart from the

feeding and nipping devices, a small clearing comb acting on the fibre ends as held first by one and then the other holding surface.

The gill feed, feeding fibre to the nip, employed in detaching tufts, was arranged so that it could move to and from the nip, instead of the nip apparatus moving. A curved form was also given to the middle of the gill combs corresponding to the circle of the travelling comb, the concavity of the gill comb working up to the convexity of the travelling comb in cases where the gill frame being stationary the gill combs as workers combed the beard of the fibre previously filled on by filling heads and projecting from the travelling combs.

The accompanying diagrams illustrate the improvements so far as they related to the mode of operating square motion combs and the improved form of combs.

Fig. 38 is a section of a portion of a machine ; Fig. 39 being a portion of a front view of the same. *a* is the travelling comb receiving the wool or other fibre from the filling heads *b b*, and in its rotation delivering the top to the drawing rollers *p¹ p¹*, whilst the noil is taken by stripper *v*. The fibre fed on to the circular comb *a*, is operating the working combs *c* formed by "gill comb bars," to which a square motion is given ; *d d* are the lifting and lowering frames which carry up and down the combs *c*. These bars or frames *d* are actuated by

the cams $e e$, affixed upon an axis e^1 , rotated by the strap e^2 acting upon the pulley e^3 .

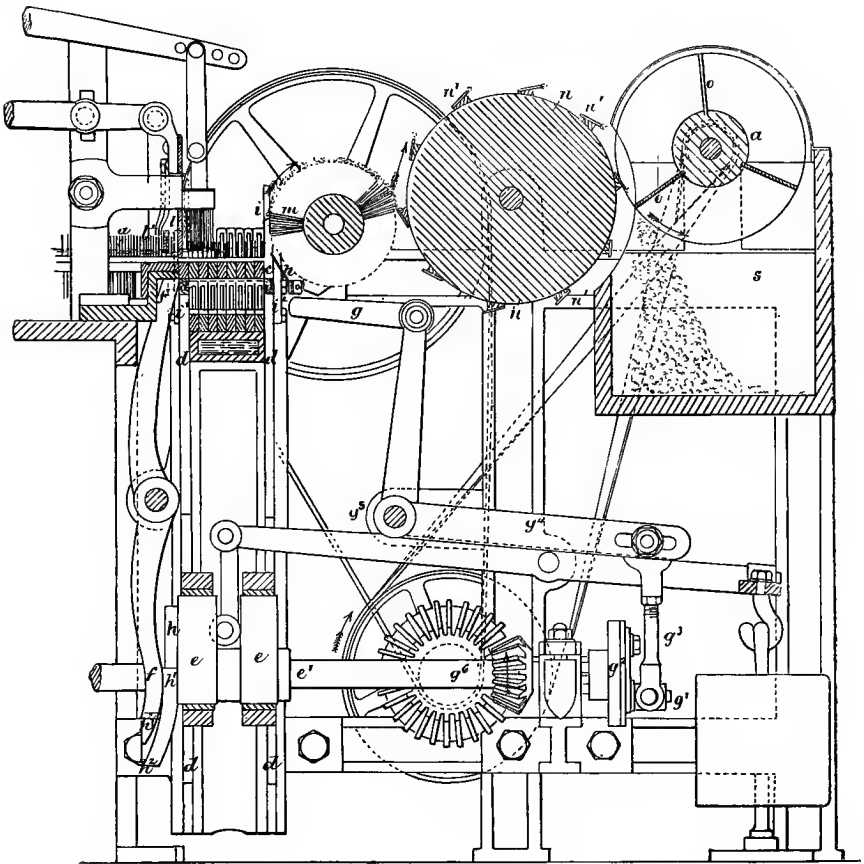

FIG. 38.—Section of portion of Machine of 5th May, 1856.

A considerable breadth of wearing surface and of altogether different proportions than were heretofore

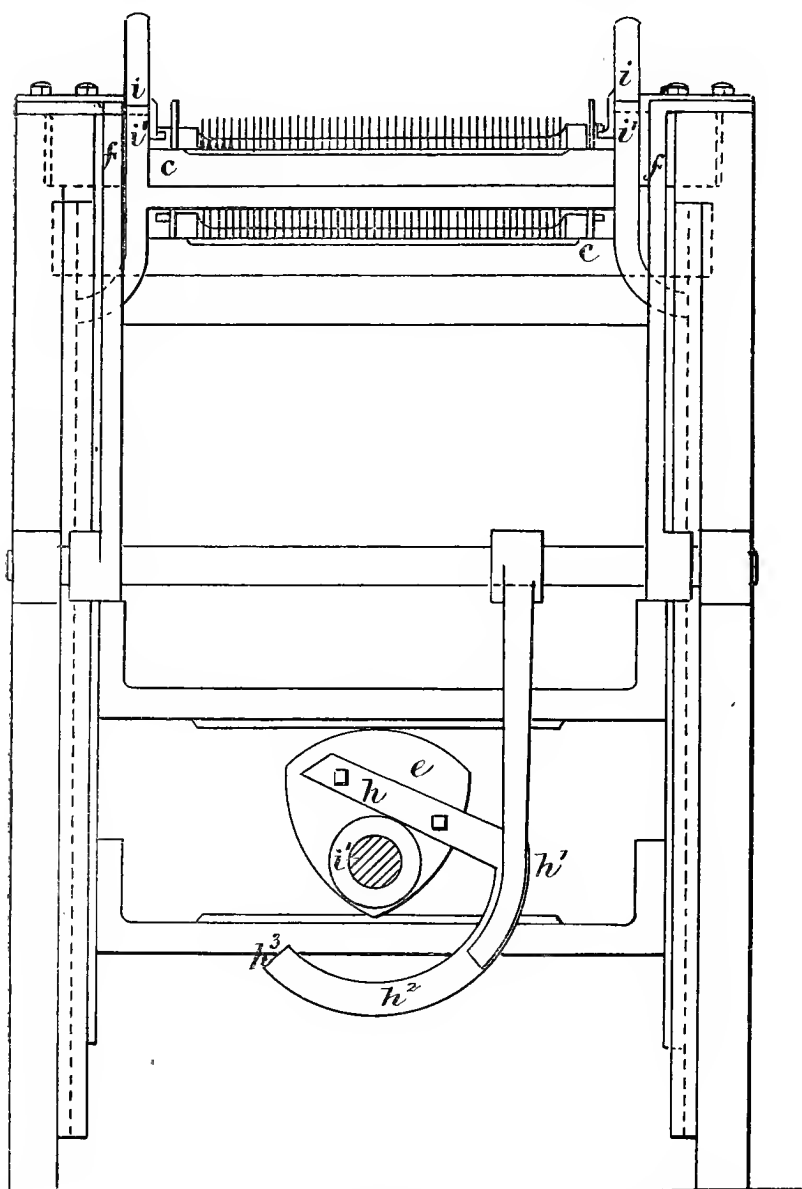

FIG. 39.—Portion of front view of Machine of 5th May, 1856.

obtained were thus given to the cams e . ff and gg are the pushing levers for giving the traverse motion to the bars c , the pushing levers ff are acted upon immediately by the tappet arm h^1 , whilst the levers gg were as heretofore actuated by a stud g^1 in a plate g^2 acting as a crank affixed upon the axis e^1 , there being a connecting link g^3 between the pin g^1 and one end of the arm g^2 from the axis g^5 , to which is affixed the lever arms g forming extensions of the plates i by which they are affixed to and slide with the bars or frames d to the comb bars c , which for the time form the upper row square in that row, whilst the bars or frames d are giving one the ascending and the other the descending motion to the bars c . The pushers ff are actuated by that part of the tappet arm h^1 referred to, which has the form of an inclined plane, viz., from h^1 to h^2 . The annular part h^2 to h^3 keeps the pushers f and the combs c in position till the guides i descend to keep the said combs upright. By the action of the fingers i in connection with the holding by the pushers f above described and combined peculiar construction of gill comb bars a considerable reduction in the breadth of such bars is effected.

Figs. 40 and 41 show the form of square motion comb bars prior to this improvement and Figs. 42 and 43 the improved form of bars. The upper surfaces of the ends of the bar of the comb, Figs. 40 and 41, are con-

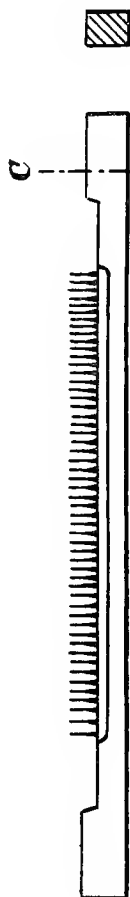

FIG. 41.

FIG. 40. — Square Motion Comb Bars prior to improvement of 5th May, 1856.

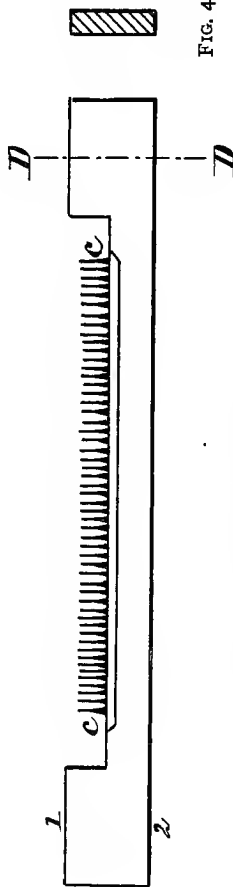

FIG. 43.

FIG. 42. — Improved form of Bars.

siderably lower than the points of the comb teeth, whereas those parts from 1 to 2 of the bar of the new form of comb, Figs. 42 and 43, are considerably deeper and thinner, and the upper edge or surface of each end of the bar at the pushing part should be about the same height as the top of the gill comb teeth or even higher. By the greater depth given to the ends of the gill comb bars, the pushing levers in giving motion to them keep them from canting or turning over sideways, and they are pushed square into their place and there kept by the pushers *f* till the guides *i i* descend to keep them firmly and square in their position. Thus formerly dependence had mostly to be placed upon the breadth of the comb bar to maintain the combs in an upright position at the time of entering the fibre as also to prevent its canting while being pushed forward. Now dependence is placed more upon the depth of the comb bars at their ends, and they can work with much greater truth, and enter the fibre closer to the head of the circle or other passing comb and by making them thinner a greater number of strokes of the gill combs per minute can be given. The motion previously proposed to be obtained by a former Patentee, and by reason of the passing or carrying comb always rotating whilst the gill combs were slowly entering and passing through the fibre close up to the head of such passing comb, a locking took place between the two combs, the

consequence of which was breakage of the fibre, increased robbings from the circular comb, and frequently also breakage of the driving wheels giving motion to the circular or other passing comb or of other of the parts as also injury to the combs; whilst, on the contrary system just described, by *immediately* pushing the gill comb away from the circle or other passing comb so soon as its teeth have entered the fibre these evils are avoided. When employing this improved form of gill comb bar and pushing means in combination with gill screws, that part is left of the screw shafts along which each bar is first pushed by the pushers without threads, and the pushers alone hold each gill comb bar till its ends enter the threads of the screws.

The improvements effected by the patent of 1856 were of striking importance—1st, by using cams as pushers, which Mr. Lister had not realized when he took the first patent for the Square Motion, and which is really the essential principle of the machine; 2nd, the ends of the comb bars deeper than the teeth; and 3rd, the guides to the bars to hold them firmly in their place during the pushing motions. These three elements, with fine short teeth, double keeping plate, with up and down motion, flat pins in front rows, and the heated race, rendered the machine most effective for the time being.

These were busy years for Mr. Holden. It took some time and a vast amount of energy and application to get the French concern into successful working, but from the day that the Square Motion was adopted, he felt no misgiving in regard to the undertaking. Now he had the opportunity of following out his favourite scheme, of imitating by mechanical movements the operations of the handcomber, and, after a series of costly experiments, he was completely successful, the wool combed by the Square Motion machine having the same polish imparted to it, the same curl or crochet, the same softness and loftiness, and the same high spinning qualities as the best handcombed wool of the old days.

From 1849 to 1852 Lister and Holden confined their operations in France to their factory at St. Denis, but in the latter year they were encouraged to extend their industrial boundaries, and founded a branch establishment at Rheims, and another at Croix, near Roubaix. The active superintendence of these three concerns, the incessant changes necessary in order to keep ahead during this transition period, and the constant strain of litigation in connection with infringements of patents, taxed Mr. Holden's energies to the full. His lawsuits were at one period very numerous. He had once eight proceeding at the same time, and he made it a rule to prepare his own briefs, and was

always present at the audiences in the tribunals. It says much for the justice of his contentions that he never lost but one of the many lawsuits he was engaged in in France. The case in which he was defeated was entered and carried through the Appeal Courts to raise and settle the point whether a few days' delay in taking a French patent after the registration of the English one rendered the former void, and the ruling was in the affirmative.

The choice of St. Denis as a centre of operations had been a great mistake ; but by the erection of the establishments at Croix and Rheims the firm more than rectified the previous blunder. The construction of these mills is worthy of a passing notice. It was novel in the combing world. The arrangement for securing economy of working, and the prevention of the mixing of the wool of different clients, was as good as it was new.

Meanwhile the Square Motion machine was being gradually perfected and a succession of patents were taken out, each of which represented a new stage of development. Mr. Lister adhered in England to the machine which he and Mr. Donisthorpe had worked into such a remarkable success, but his mind had by this time been wedded to other enterprises, and in 1858 he sold his share in the French concerns to Mr. Holden.

Soon after this arrangement had been effected—in

January, 1859—the firm of “Isaac Holden and Sons” was established, Mr. Holden’s two sons, Angus and Edward, being taken in as partners, as also were Mr. Jonathan Holden, who became the managing partner of the Rheims concern, and Mr. J. H. Crothers, upon whom devolved the management of the works at Croix. The St. Denis works were abandoned in 1860, their distance from the seats of the special industry with which woolcombing is connected being too great for thoroughly convenient working. In 1864, the firm started the Alston Works at Bradford. Since then the whole three establishments have been carried on with ever-increasing success. The extent of their operations may be gathered from the fact that at their three establishments they have a combined area of flooring of over forty acres, and that they comb an average of 31,166,666 fleeces annually, consisting almost entirely of merino wool. Looking at the immense aggregate these figures represent, we have an industrial enterprise which, in value and extent, is perhaps the largest of any kind in existence.

It now remains for us to trace how the Square Motion machine, which has been the means of building up this great business has been brought, step by step, to a condition of such perfection as to have commanded this wide influence.

CHAPTER XIII.

FURTHER DEVELOPMENTS OF THE SQUARE MOTION.

How persistently Mr. Holden applied himself to the improvement of the Square Motion machine now is evidenced by the several important inventions which were added to it—inventions which were the result of incessant experiment—during the first few years of its adoption in France.

Within about half a year from the taking out of the patent last described—viz., on the 30th January, 1857—he had taken out two more patents for improvements of great value. The first (No. 279) related to operating upon the wool between the carrying comb and the drawing off rollers by other comb teeth, called “nacteur” combs, serving to keep back the knots and dirt from the fibre as drawn from the carrying comb teeth, the teeth of this intermediate comb pointing in a substantially opposite direction whilst they travel in a direction parallel to that of the carrying comb, and when the carrying combs are in a circle these intermediate

comb teeth are inclined in a large circle concentric to the concentric with those of the carrying comb teeth, being in the fibre only at or about the point of drawing off, and separated at the feeding, or alternatively the intermediate comb teeth are arranged in segments consecutively coming into operation. When straight carrying combs are employed the intermediate combs are arranged to operate in a line parallel to that of such carrying combs.

Further, the invention relates to means of transfer of the wool from the comb into which it has been fed to the teeth of another to be drawn off, by causing the teeth of one comb whilst pointing towards the other to come into position to take the fibre as pushed off or drawn up out of the carrying comb, the noil and dirt being kept out by the carrying comb, it being laid into and behind the teeth of the taking comb and there left in the drawing off by the drawing off rollers.

The improvements also relate to funnels for conducting fibre from the feed to passing combs to be combed. Such of the ordinary funnels or mouthpieces having openings through them sufficiently large freely to allow of the fibre passing without pressure, Mr. Holden reduced the opening so that the sliver was subjected to considerable compression, and friction was put on it, and the length through the funnel was increased to at least equal to the length of the staple.

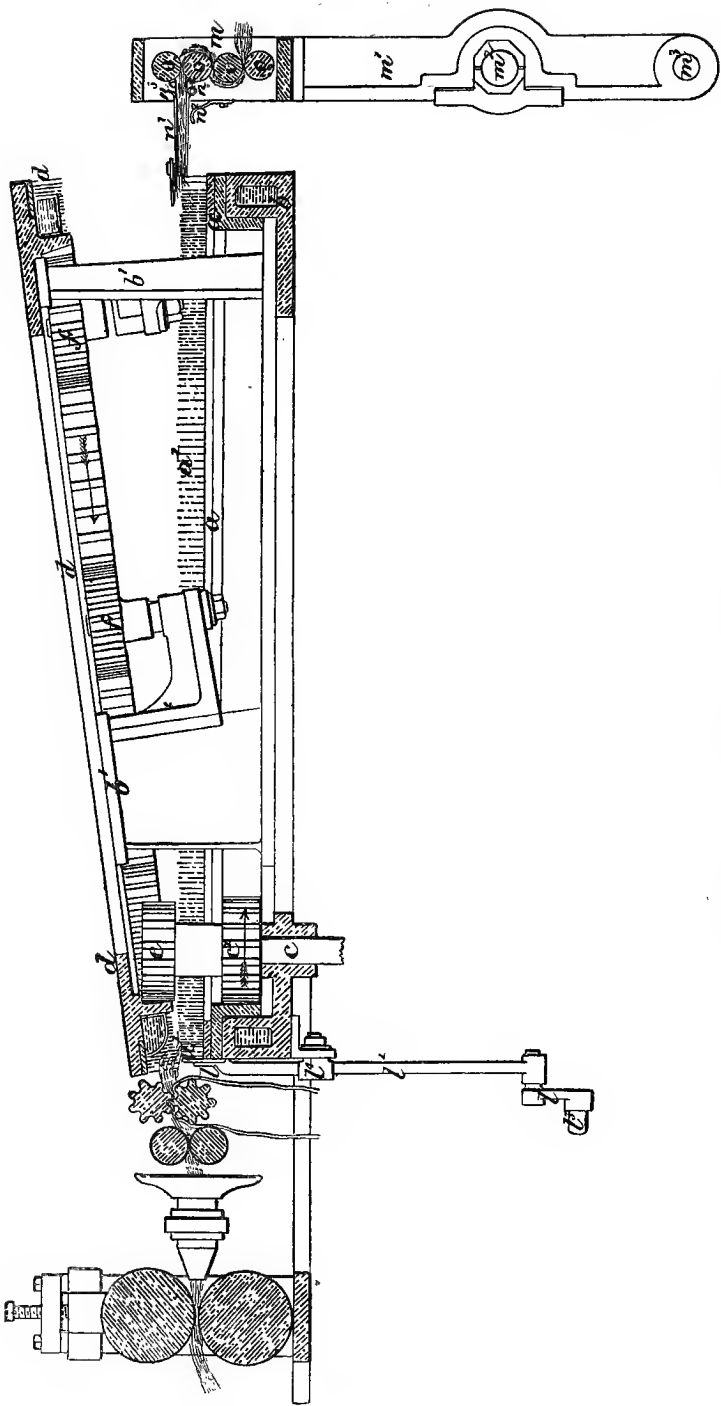

FIG. 44.—Sectional View of Working Parts of Machine of 30th January, 1857.

The mouthpieces were also made with hinge joints in order to admit of the motion of the feeding means, and

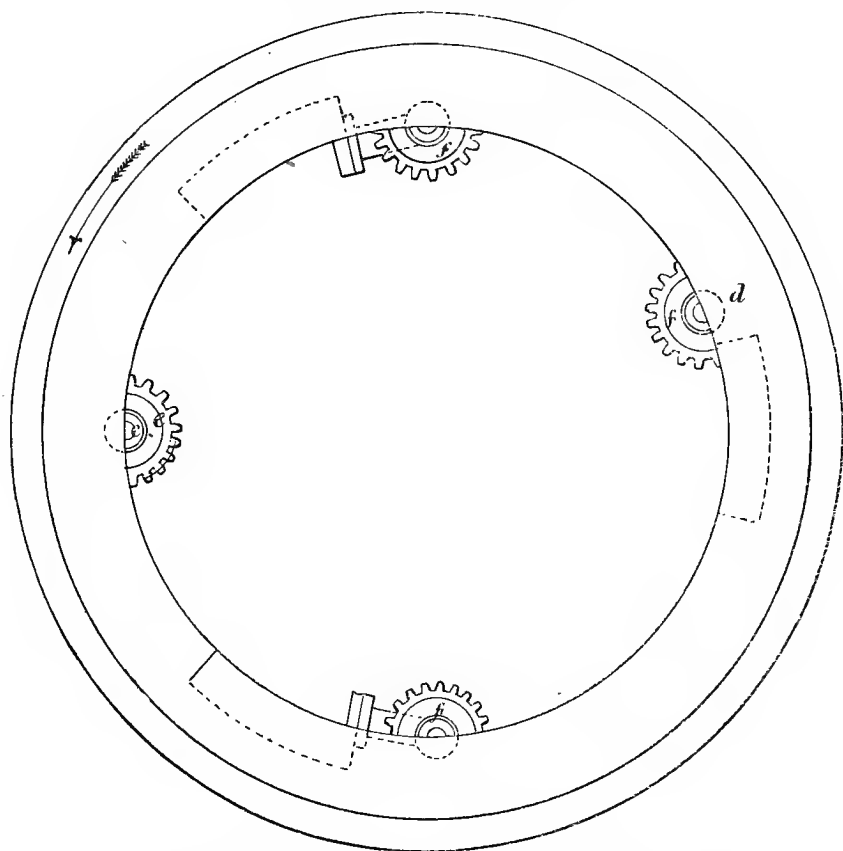

FIG. 45.—Plan of Working Parts of Machine of 30th January, 1857.

the fibre was fed to the mouthpiece by plain in place of fluted rollers. For such mouthpieces, a series of plain rollers, the supporting frame of which is capable

of motion to adjust itself to the line of draft between the holding feed rollers and the comb to which the fibre is fed, were substituted.

The following is a description of the drawing:— Fig. 44 is a sectional view and Fig: 45 a plan of such working parts of a woolcombing machine. *a* is the section of an ordinary circle of carrying combs, *a*¹ being

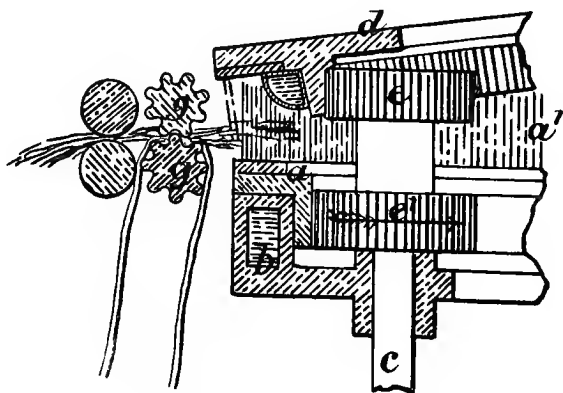

FIG. 46.—Detached View of Circles.

the comb teeth, which are heated by steam in the hollow chamber in the table *b*, whilst the circle rotated driven from an axis *c a* is another similar circle of comb teeth, supported by the framing *b*¹, and rotating with the circle *a*, not exactly in the same plane, but at an angle thereto, the teeth pointing in a direction opposite to those of the circle *a*. The rotary motion to the circle *d* is given by the pinion *e*, the axis *c*, and

taking into the teeth inside the circle *d*. Other pinions, *f*, supported from the stationary framing, and which take into the teeth of the circle *d* only serve to guide

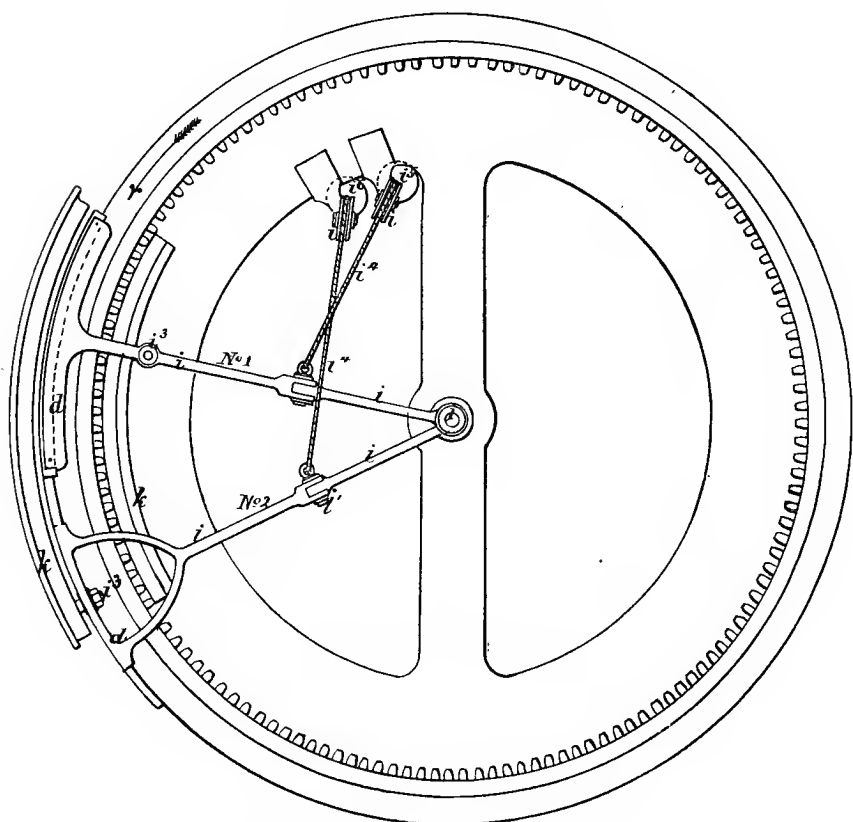

FIG. 47.—Plan View of Segments of Combs.

the circle *d* correctly in its motion. The circle *d* is at such an angle to the circle *a* that sufficient space may be allowed at one part thereof for the laying on of fibre,

and another portion of the circle d approaches so near the circle a that the teeth of the circle d at such time come in front of those of the circle a (see detached view of this portion of two such circles, Fig 46), the fibre being fed to the circle a at the point where by the angle given to the circle d there will be sufficient room for the purpose, and in the rotation of that circle a , the teeth of d will gradually approach those of a , till they successively penetrate the fibre projecting from the teeth of a , at which time the fibre will be brought opposite the drawing off rollers g , and be drawn off through the teeth of both the combs, a and d , and be more effectually cleansed. Alternatively the intermediate comb teeth d were arranged in segments consecutively coming into operation to act in a similar manner to what has just been described.

Fig. 47 is a plan view, and Fig. 48 a section of an arrangement of such segments of combs d . Two segments d No. 1 and No. 2 each supported upon a lever arm i jointed at i^1 , are capable of turning upon the fixed centre of motion j . They have each a pulley i^2 turning on pin i^3 , which constantly travels in the groove in a stationary frame k , one of which is shown separately by front view at Fig. 49. The lever arms i have attached to them weighted cords i^4 which pass over pulleys l . The weights l^5 being sufficient to give the arms i , with their combs, a tendency continually to

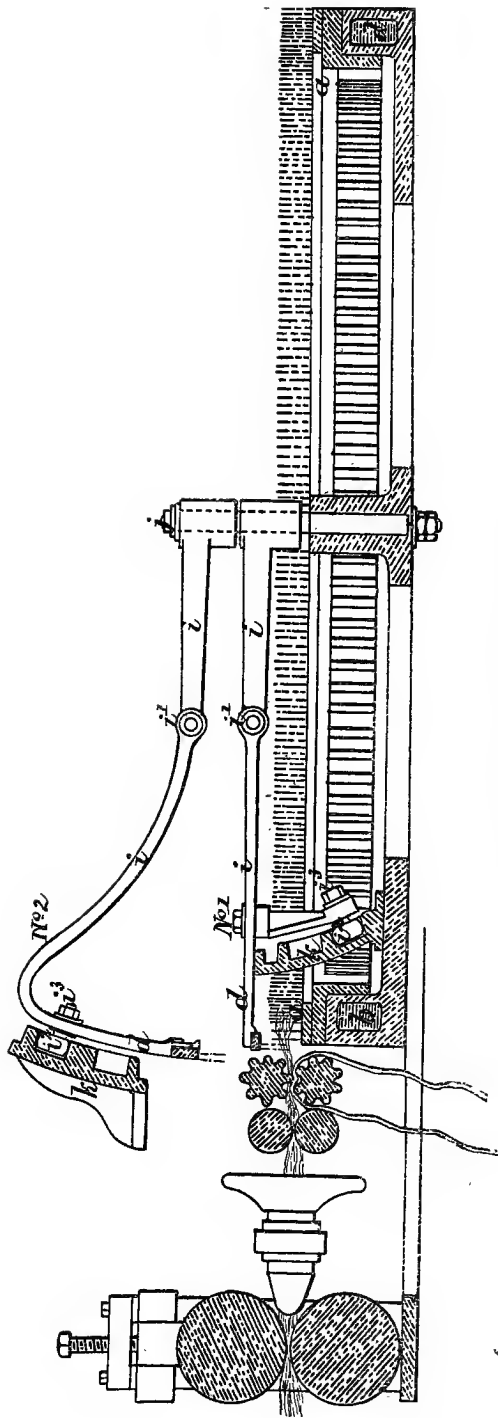

FIG. 48.—Section of Segments of Combs.

move towards the pulleys l , No. 1 comb is in the fibre of the comb a , and that fibre is being drawn through the teeth of both combs a and b , and the bowl of arm i is in the lower groove of its frame k , keeping the teeth of that segment fully in the fibre carried by the comb a , so that the segment follows with the circle a in the direction of the arrow. The pressure exerted by the weight i^5 attached to that arm in the opposite direction being overcome by the adhesion of the fibre, but so soon as that comb d has arrived with its bowl i^2 at the

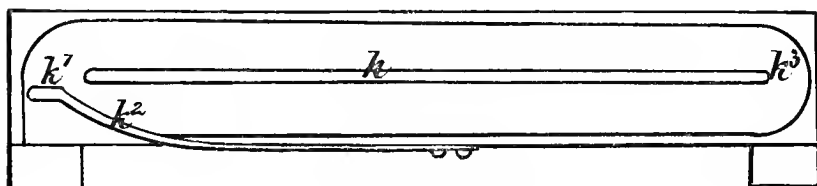

FIG. 49.—Stationary Frame.

point k^1 of its frame k , the spring k^2 thereof acts upon that bowl to raise it into the upper groove in the plate k , whereby the teeth of that segment d will be raised out of the fibre in the comb a , and the teeth of that segment d No. 1 being freed from the fibre the weight i^5 will draw that segment to the end k^3 , when the weight of that segment will again cause the teeth to penetrate fresh fibre in the circle a , and by contact with which to move along therein again with the circle a , the bowl i^2 thereof being again in the lower groove of

its frame k ; and although the segments $d d$ are described as adapted to circles of carrying combs when straight passing or carrying combs are employed, such intermediate combs will readily, from what has been stated, be caused to operate in parallel lines, or nearly so, to such passing or carrying combs to effect the object desired.

When the patent of 1856 was taken Mr. Holden was devising and experimenting on improved methods of actuating the square motion combs, which he patented 30th January, 1857 (No. 280). This patent deals with modifications of the apparatus for actuating the working comb bars in the square motion frame, differing from those described by his patent of 1856, and consisting in reciprocating those bars by quadrangular frames made more than deep enough to receive with them the ends of both tiers of bars, and wide enough to bear against the outer surfaces of the two outer bars of the tier for the time having the majority of bars, admitting of their moving up and down therein in course of travel, and at the same time keeping them square, independently of the lifting and lowering frames and otherwise facilitating operation. Also one cam, instead of two cams as in the 1856 patent, was enabled to do the work of operating the raising and lowering frames simultaneously. Also operating the lifting slides of the gill bars connected to

the lowering slides at the same end, so that each connected lifter and lowerer may be operated by one separate cam with friction pulleys; combinations of direct cam action for motion in one direction and lever action for motion in the other direction are described for actuating the gill bars; also other combinations for like purpose. Mr. Holden further shows the races between the upper and lower series of gill bars made as steam chambers to heat the teeth. Also the bottom is made as a steam chamber, extending its surface to beneath the descending gill and ascending gill, to give more heating surface, thereby removing difficulties involving limitation of distance of lift for the frames. Also the ends of the gill bars were shown hollowed, and some of the end teeth next the drawing off roller were designed longer.

In Fig. 50 *a* is the driving shaft; *a*¹ pulley; *b* cam acting on friction rollers *c c* on cross bars *c*¹ *c*¹, connecting two slide frames *d d*, one to each side of the machine, so that they act together; *f* gill combs; *e* other slide frames each side of the machine, and enclosing gill comb ends and working five comb, with width thereto for containing three of them, and embracing the combs and upper steam box *h*; *g* lower steam box on which partly and on a projection *i* the frames slide on studs *j*; *k* shaft having arm *l* whose pins *l*¹ act between two projections *n, o* on the slide *e*

to move it; m is an arm dependent from axis k to support two friction pulleys pp , which, co-operating with the cam g , reciprocate the frames ee , the cam b raising and lowering the slides d , which lift and lower

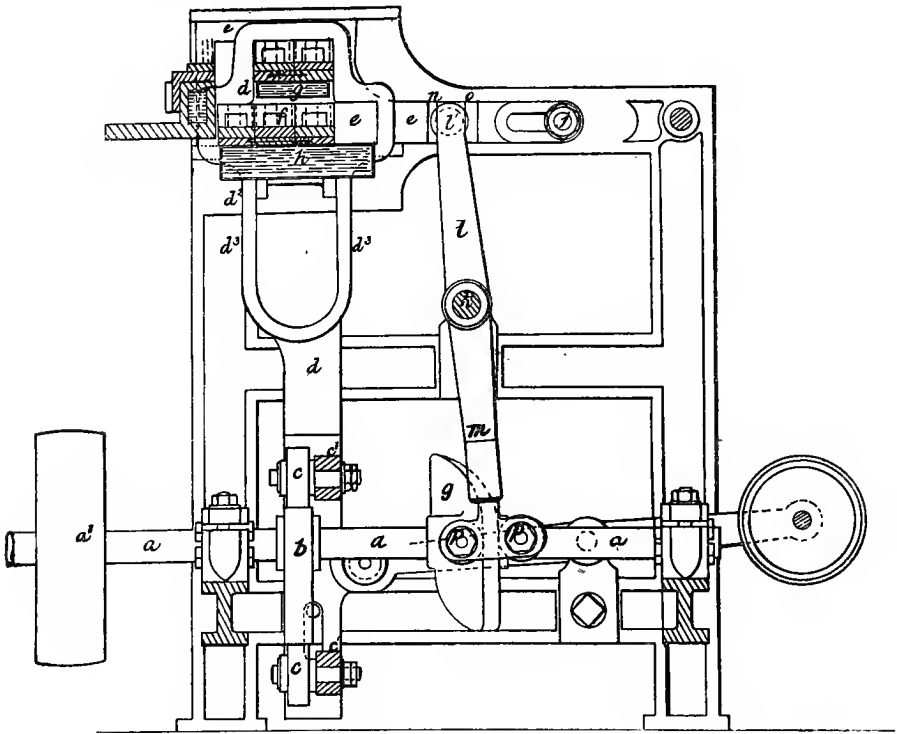

FIG. 50.—Section of Apparatus.

the combs f from the lower to the upper races h g respectively, the slides e pushing a comb as soon as lifted to the upper race horizontally. By providing steam heater g in addition to heater h Mr. Holden

more intensely heated the gill bars. The slides *e* keep the ascending and descending comb bars squarely in position without aid from the upright slides *d*, and by narrowing the upper race *g* within two combs' breadth and increasing the recesses *d*¹ *d*¹ in the frames *d* beyond the breadth of a comb bar, Mr. Holden obviated the necessity of the precision of fit and push previously requisite.

In Fig. 51 *a* is the shaft carrying the driving pulley *a*¹. A separate upright slide frame *d* one to each side, each raised and lowered by separate cam *b* on shaft *b*¹, driven by pinions *b*² *b*³. Each cam *b* moves its frame *d* by connected friction pulleys thereon. Shaft *b*¹ moves the shaft *k* by tooth wheels *m*, and by two cams *l* reciprocates the two horizontal slides *ee*, one at either side through the intervention of two friction pulleys *nn* carried by the slides, without the aid of levers or cross bars.

These improvements, embodied with others in all later square motion combining machinery, enabled it to hold its present pre-eminently useful position.

About this time Mr. Holden first introduced the stripping indented edge like a doffing plate with a similar turned up doffing plate on each side of it to strip the noil off the circle, and the robbings off the square motion working combs, which was not patented.

It has been employed ever since, and has been found exceedingly valuable.

The year of the inauguration of the firm of "Isaac

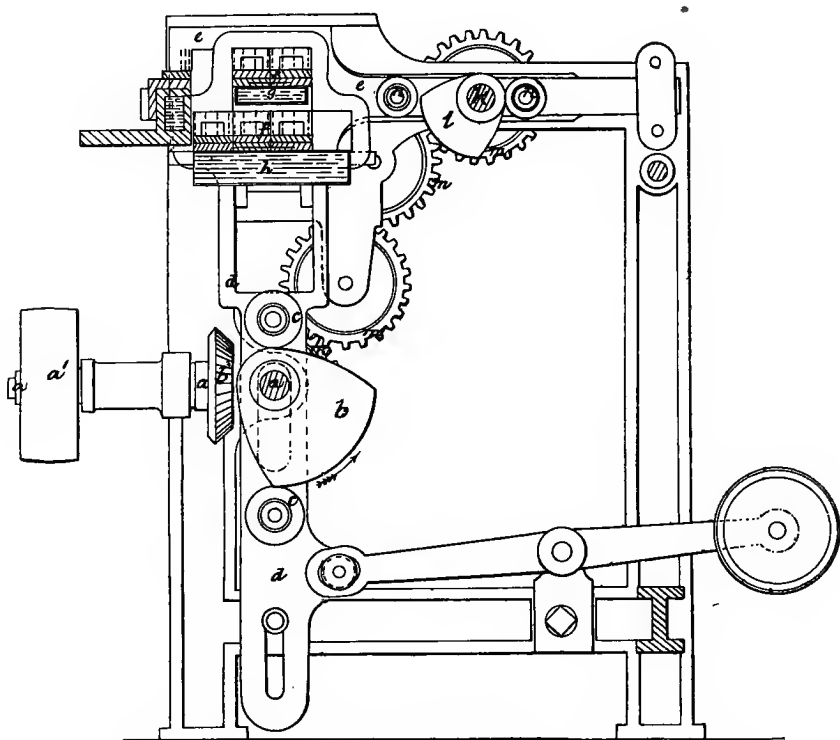

FIG. 51.—End View.

Holden and Sons" was signalled by the introduction of a very noticeable and highly useful improvement, part of which was the suggestion of Mr. Angus Holden. We must again allow the specification of

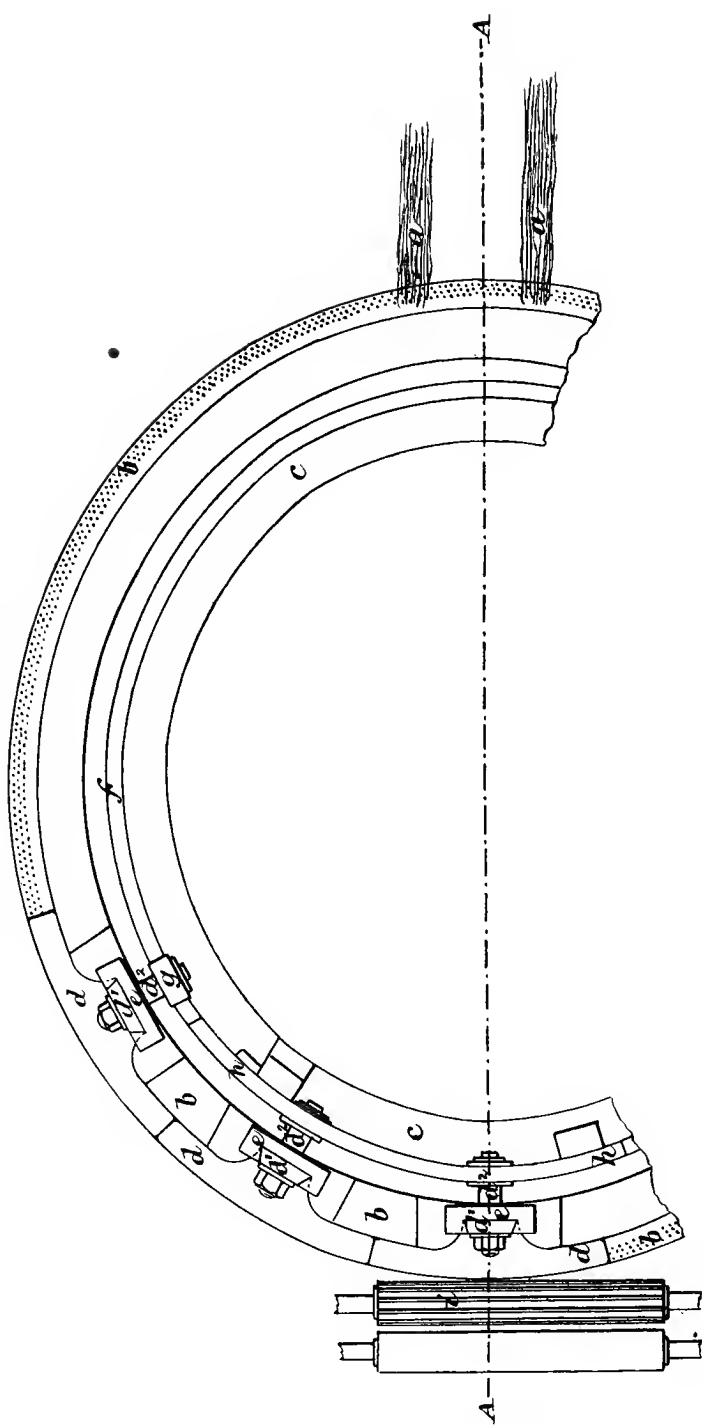

FIG. 52.—Plan of Segmental Combs.

patent (No. 52, January 7th, 1859) to tell its own story.

In one portion of the illustrated apparatus the design of Messrs. Holden was to pass the wool in succession through two sets of gill combs, at the taking gills, so reducing speed as to make it accord with the speed of the feeding rollers, obviating any draught. Also provision for one set of gill teeth in ordinary single gill preparers to point in one direction—downwards, and the next set in the opposite direction—upwards.

In another portion the circle of receiving combs b , shown in plan Fig. 52 and in elevation Fig. 53, receiving fibre in tufts aa are supported on a fixed table c to rotate thereon by the operation of a toothed pinion engaging teeth b^1 on the circle b . The strikingly novel and permanently useful feature was the cutting up of the “nacteur” combs, introduced by previous patent No. 279 of 1857, into a series of segmental combs, as shown in the present arrangement under description and marked d, d, d , moving with, but pointing in opposite directions to, the carrying comb b . These segmental combs descend into the wool between the circle teeth and the drawing off, and then rise out of the way, at other parts, of the feeding means and working combs.

These segments running up and down in grooves in vertical pillars, under the influence of pulley sg on

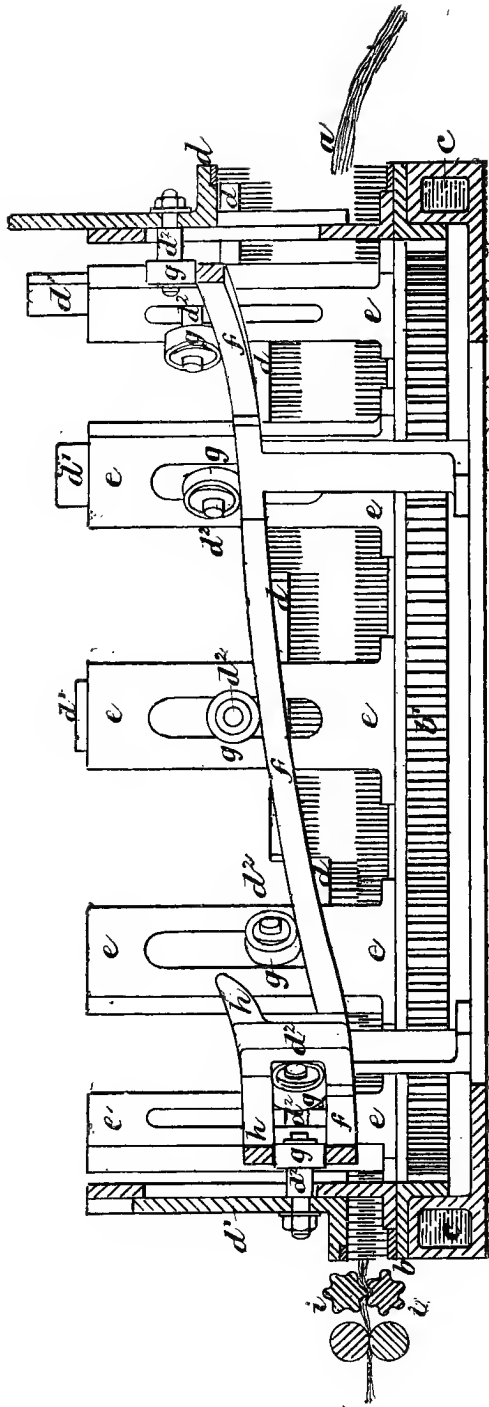

FIG. 53.—Section of Segmental Combs.

studs d^2 projecting from them travelling up and down guide-ways f , these pulleys g at the point of draw off, where the action of the "nacteur" takes place, are held more firmly by being embraced by another bar h parallel to f , as they successively arrive there, ii being the drawing off rollers.

Fig 54 shows a pair of feed rollers supplying wool a on to combs l , affixed to an arm l^1 swinging on an

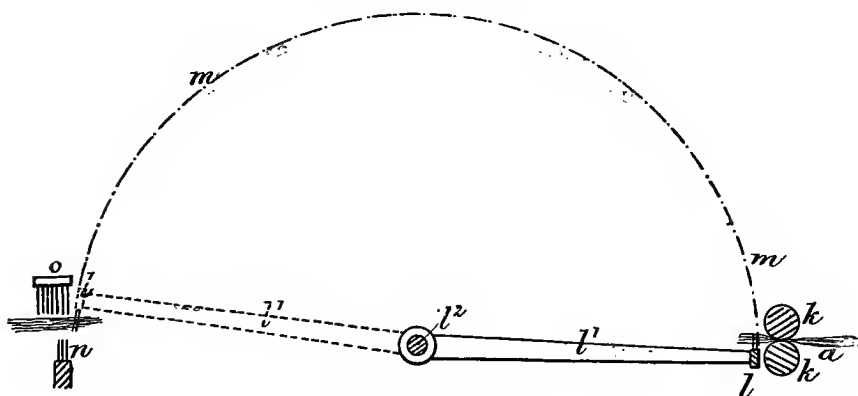

FIG. 54.—Feed Rollers.

axis l^2 on the line m , and by them delivering the wool to carrying combs n aided by a comb or brush o , which reciprocates to and from the comb n , and having delivered its tuft, each time it swings back for fresh supply, and so on. The device m ensures proper lodgment of the successive tufts in their appropriate locations on the carrying circles.

In the patent of January 1857 (No. 280) Mr. Holden

had patented, with several other forms of working the square motion, the direct action lift and push, in separate frames, at each side of the machine, and heated race between the upper and lower combs. These, in connection with the segmental nacteur, gave the firm a machine approaching perfection, which imparted new vitality to their business, without which, in the face of growing demands for good work, they could not have continued their existence. Mr. Holden writes: "Had I not known its value, even then, when it was yet undeveloped, I could not have had the courage to have bought the business, and if I had, without it, I should have been ruined by the purchase. Even with it, and without later improvements, notably the patent for improved sliver, I should have been ruined."

On the 29th of March, 1860, a further patent was necessary for the protection of additional improvements. In this patent were embodied three inventions, amongst other novel devices, of great beauty in operation and effect. The first in question was a method of operating the keeping plate, such as was introduced by Mr. Holden's prior patent of 1856, directly from the perpendicular slides of the square motion, and so attaching and controlling this plate as to make it move with the circular comb by its contact in its downward movement, and during upward movement it might be drawn back

by a spring ready to descend again at the same point as before. In Figs. 55 and 56 by plan view and a sectional elevation respectively, is shown how this

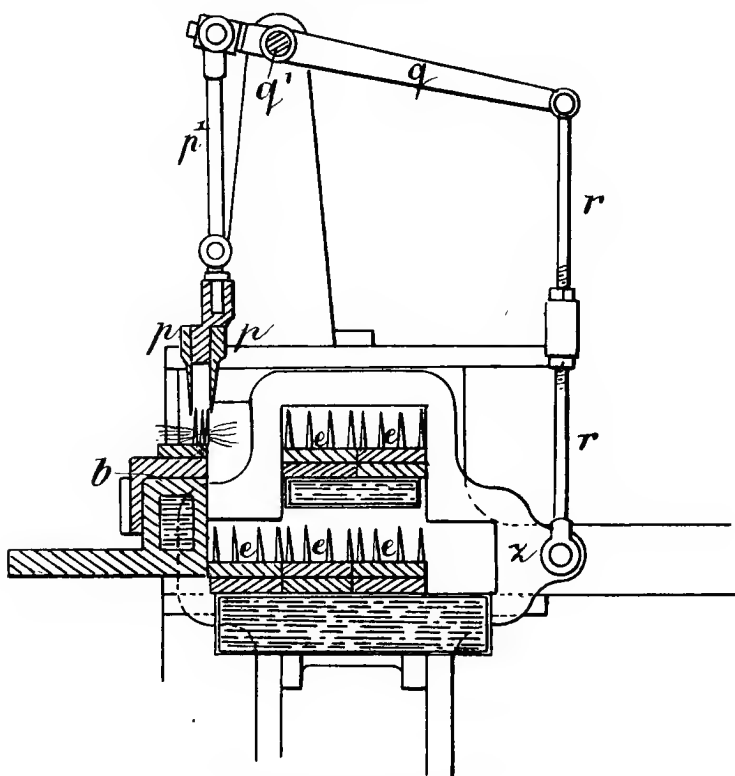

FIG. 55.—View of Motion.

movement is effected : b being the travelling comb ; ee the working combs ; p the keeping plate suspended by jointed rods p^1p^1 to one end of levers qq , having fulcra at q^1 , and their other extremities attached

by rods *rr* to the square motion frames *z* used to impart vertical motion to the combs *e*. In Fig. 56 the comb *e*¹ has arrived at its extremity of motion horizontally, and is about to descend into the wool. Simultaneously the plate *p* descends and nips the wool during horizontal motion of comb *e*¹, rising whilst a comb of the upper series falls, and during combining plate *p* can follow the rotation of comb *b* impelled by friction on the wool, rising and resuming its vertical position by aid of spring *s*. Fork *t* guides plate *p* in its lateral to and fro travel.

Lastly, is the method of pushing away the comb bars from the circle of carrying comb before those bars become raised to their full height, thereby assuring the avoidance of a possibility of locking or jamming of teeth in the combing operation.

In Fig. 56 is shown sufficient of a square motion series of combs to enable the principle of this motion to be understood. Modifying the operation effected by his previous patents, this invention was designed by Mr. Holden to give to the rising square motion comb entering the wool, a curved motion, by so actuating the slides of the comb bars that they begin to impart horizontal motion before the vertical rise is completed, and so by these combined forces the bar entering the wool also recedes from the carrying comb, describing an oblique direction, until at their highest vertical

elevation. b is the carrying circle comb with wool to be worked by the square motion combs $e^1, e^2, e^3, e^4, e^5, e^6$, in succession, entering it vertically, passing into and away obliquely, and traversing horizontally, parting from the wool by a vertical drop, and by inverse motions returning to its succession in the worker series. The comb bar is in its normal lower comb, bar e^2 is at the point where it passes by the operation of the slide, controlled by an appropriate cam which pushes it from its

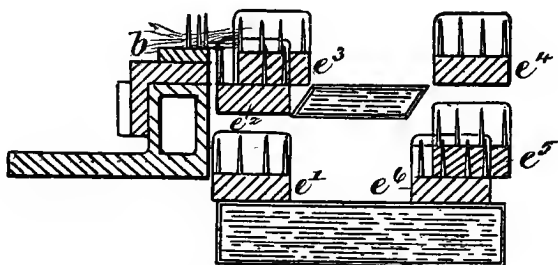

FIG. 56.—Sectional View of Motion.

vertical line of rises obliquely to the fullest attainable height at e^3 , when it goes horizontally to position e^4 , dropping vertically to position e^5 , then assuming position e^6 , and thence back to e^1 to resume its endless journey.

At this time (we learn from the before-mentioned autobiographical notes) Mr. Holden felt it was necessary to remodel all his machinery for washing, carding, combing, and gilling, and to perfect the Nacteur

comb, from which he anticipated a new life. To accomplish this he thought it expedient to remove to Bradford, and he purchased a small mill there—the “Pennyoaks,” as it was called—and adapted it to the purposes of a mechanics’ and experiment shop. It was opened in January 1861. In this place a great many experiments were made and experimental machines built, upon which some £20,000 was spent, but the ultimate expenditure entailed by these operations did not fall short of £100,000.

Mr. Holden’s object was not only to get perfected machines with which to renovate all the firm’s works, but also to test their system by comparison with the best of competing systems, and to ascertain whether they were really on the best and safest lines of working. These matters occupied Mr. Holden’s thoughts and anxieties to such an extent during some four years of excessive application that his health broke down; but, fortunately, the firm’s success was so complete that their business, which had to dispense with his services for several years, could well afford to do so. His doctors insisted on an entire change of occupation and rest, so he devoted himself to public and parliamentary work for a time.

At “Pennyoaks,” Messrs. Holden had a good staff of mechanics, under the able direction of Mr. Thomas Craig. They tried many forms of the combing

machine,—one 2 feet diameter, one 3 feet diameter, and several 4 feet diameter circles. The circle up to that time had been 37 inches in diameter. They ultimately adopted the 4 feet circle. One form of combing machine was tried with the circle running on bevelled carrying pulleys steadied by lateral guide pulleys, both made of lance wood. Another, with the circle supported and running on cast-iron spherical balls was also experimented with; and then they adopted in their next model the circle supported by a stud in the centre and driven by a worm working in the teeth of the periphery. Then they were led to the plan now in use, of driving with stud wheels, one driven by the worm and the other taking into the teeth of the periphery. Various methods of heating the circle with gas were tried, but at last a return was made to steam, admitted into the base circle on which the circular comb revolves, and for this purpose used high pressure steam generated by a Scott's boiler.

The next invention of moment in connection with the Square Motion machine was patented on the 27th June, 1862. The specification described various modifications of existing apparatus, including a method of actuating the gill bars, somewhat differing from that prescribed in patents No. 1058 of 1856 and No. 280 of 1857; an arrangement of reciprocating brushes by cam

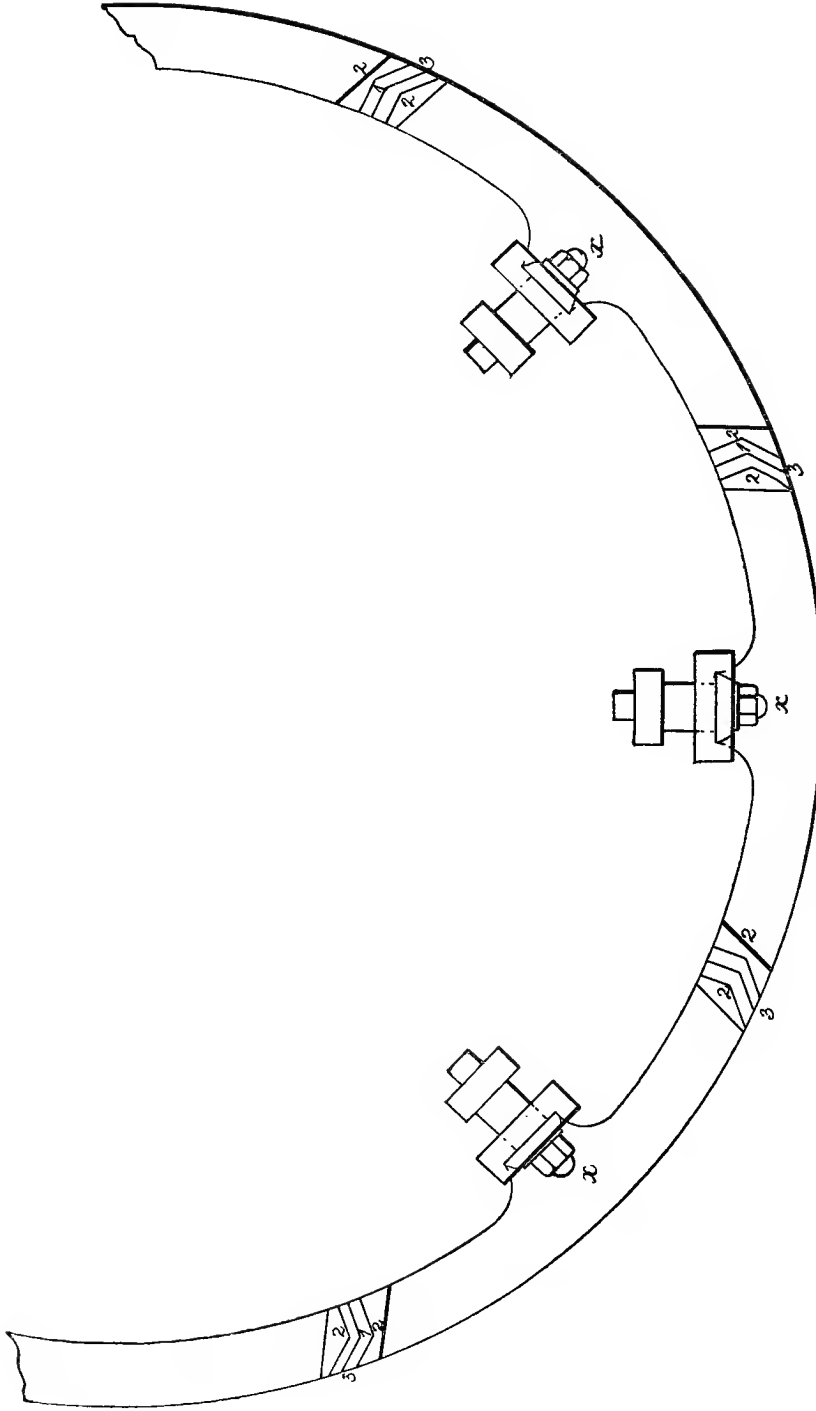

FIG. 57.—Improvements of 27th June, 1862.

action, operating to aid correct laying of fibre passing from comb to comb ; alteration of form of gill bars when their combs act as working combs ; providing a rotating plate to aid in lifting fringe of fibre in circle ; facilitating the heating of comb teeth by projections passing down into the fire heat ; star wheel motion to eccentric filling heads ; forming comb teeth flat to aid operation of keeping plates ; also forming adjoining ends of "nacteur" comb heads of sections, inclining upwards from each other to facilitate up and down motions avoiding breakage of teeth in passing one another, such parts being also inclined horizontally so that the teeth of one section overlap those adjoining.

The accompanying Figs. 57 and 58 illustrate the foregoing : x marks segments of "nacteur" combs ; x^1 their teeth, inclined from (1) to (2) facilitating their passage in rising and falling and avoiding injury of teeth by the sides from (1) to (2) of adjoining combs, the points in the event of meeting readily sliding without injury down those inclines. The inclined line (1) to (3) indicates how the adjoining parts with teeth in them overlap each other so as not to interfere with continuity of operation of the teeth of the "nacteur" combs ; and lastly, to driving the main comb circle by a screw acting directly on rack teeth formed peripherically of the comb frame circle instead of by an internally located rack as previously was the

practice, thereby securing more equable and steady driving.

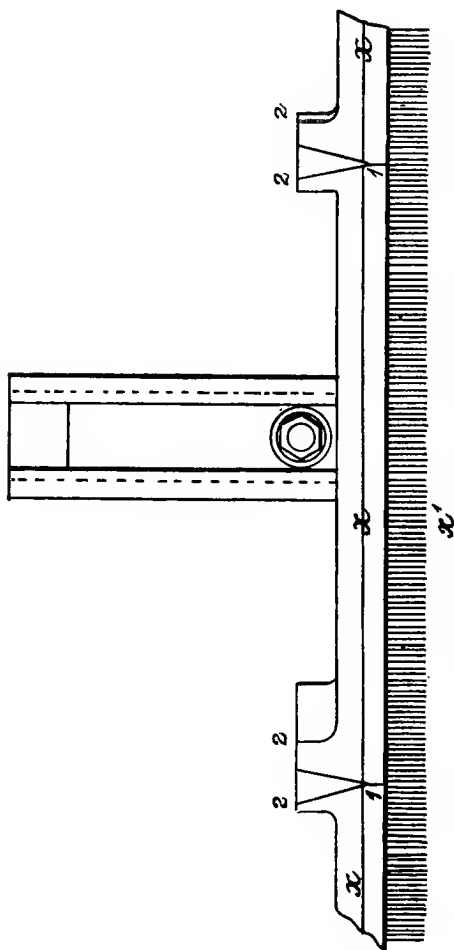

FIG 58.—Improvements of 27th June, 1862.

Figs. 59 and 60 illustrate this change, A being the comb circle, A' the teeth in the periphery, B the driving

screw engaging those teeth, *c* a plate to protect fibre in the teeth of *A* from being injured by the teeth of the screw *B*.

In December of the same year Mr. Holden secured a patent (No. 3394) for an invention particularly noticeable as embodying the employment of pairs of round pillars which supported the segments of "nacteur" combs in their rising and falling motions, as they traverse around with the circle of carrying combs, to and away from the working combs. At first they

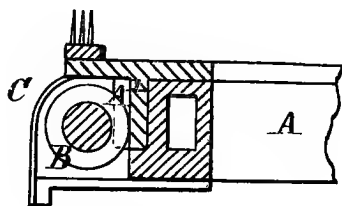

FIG. 59.—Screw Action.

began at "Pennyorks" by using one round pillar with slot and tongue to support the segment nacteur combs, but this was found to be uncertain, hence the invention of the two-pillar system, which proved to be admirable for securing uniform and steady action. The other devices, although useful and ingenious, would require too much description and illustration for the space at our command.

Figs. 61 and 62 show, by section and front view

respectively, the construction and application of the

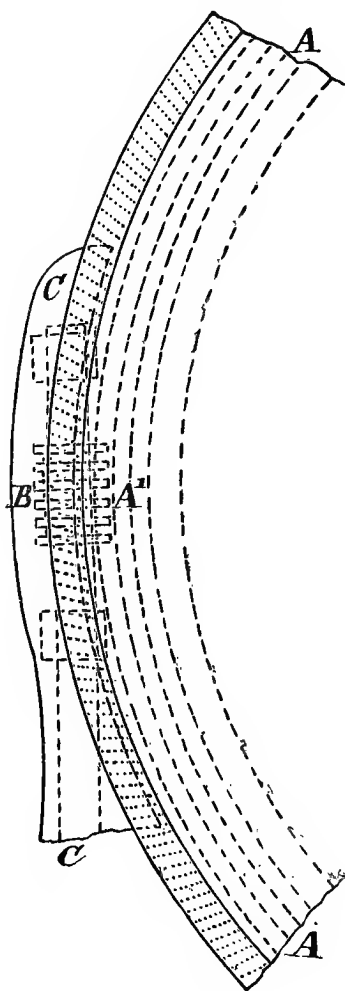

FIG. 60.—Screw Action.

pillars marked o^3 o^2 , being sockets formed on the

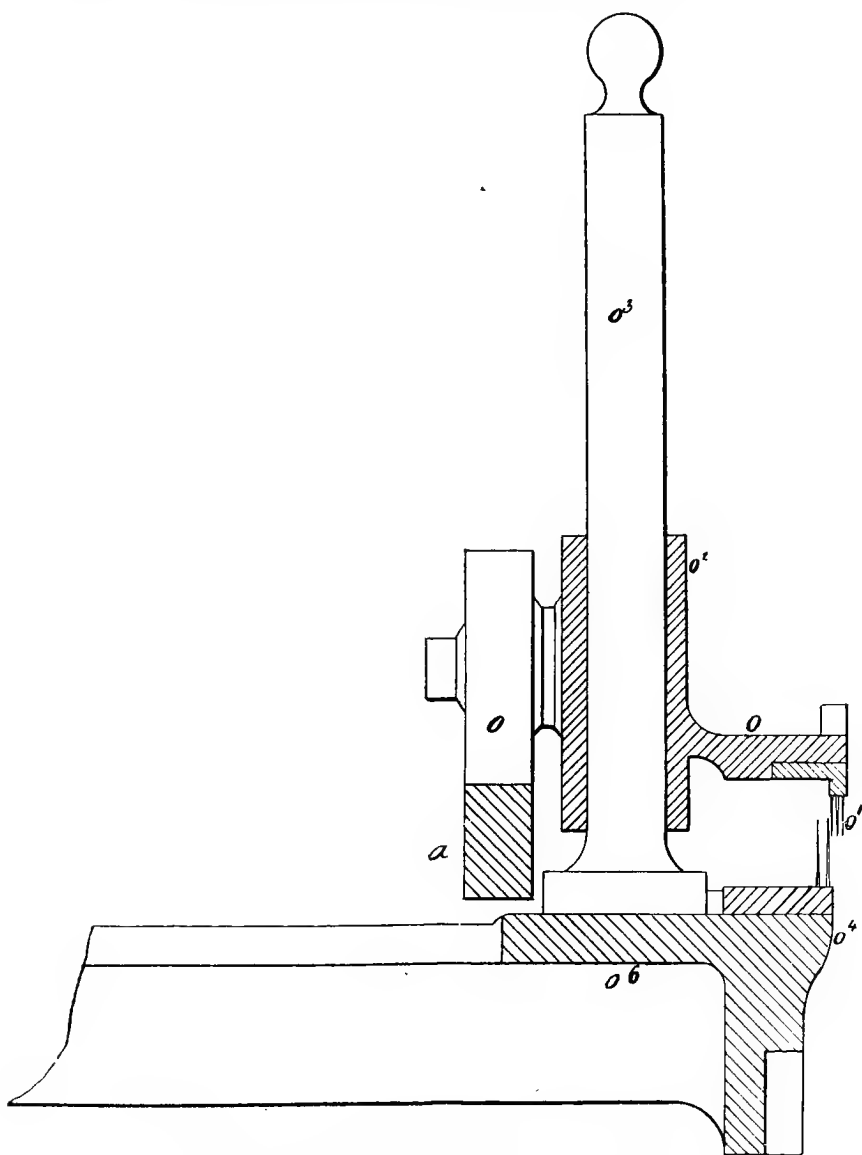

FIG. 61.—Section of Conductors to “nacteur” Combs.

A A

frame o carrying the “nacteur” combs o^1 , which sockets slide up and down on pillars o^3 as guides, as they are

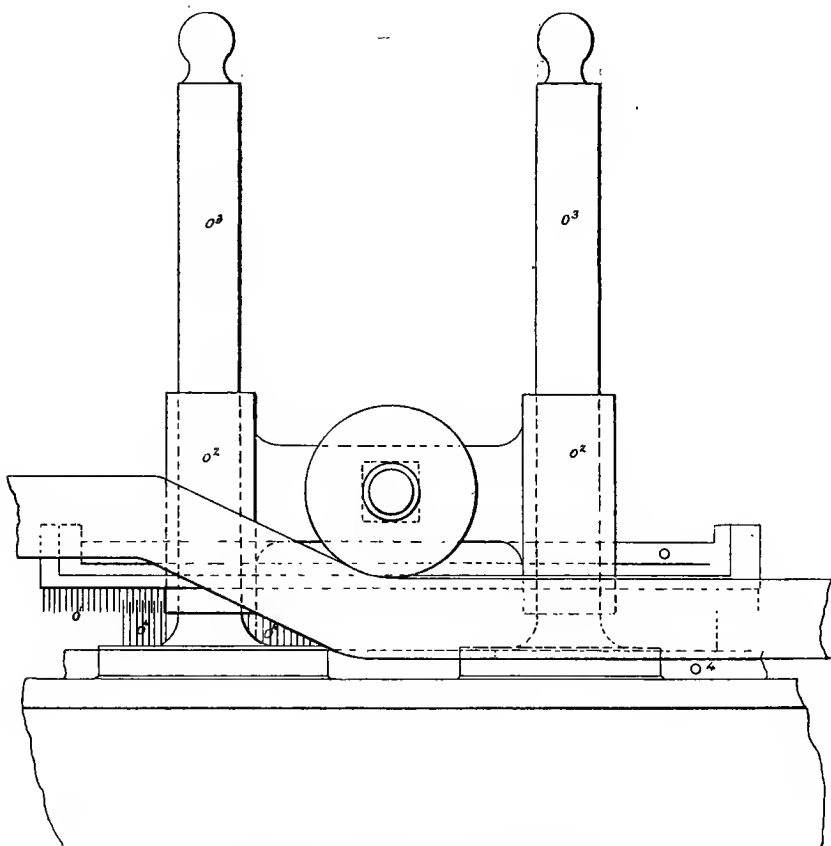

FIG. 62.—Front View of Conductors.

raised and lowered by the wheel o^5 running around on the cam course a . The pillars o^3 are affixed to the frame o^6 of the carrying comb circle o^4 .

The position of the Square Motion machine was thoroughly established by these successive improvements, and the perfection of its working and the beauty of its work rendered it pre-eminent for the classes of wool upon which it was mostly used. Still the task of development was not considered complete. Every year seemed to bring some new idea of improvement to the mind of Mr. Holden, and though many of the inventions which were introduced might be regarded as of a minor character viewed as single stages of advancement, yet when the efforts of a few years were taken into account together it was seen that they constituted a progressive aggregate that was of remarkable value. It is necessary to state, also, that while the inventions which were made the subject of patent were very numerous, the improvements in details of working, which could not be patented, but which were nevertheless of the utmost importance in the attainment of perfect results, were equally numerous. Such results naturally led to a wonderful development of industrial activity on the part of the firm, and they speedily became the largest operators in this special branch of industry.

Mr. Holden began at "Pennyoaks" with the present direct action square motion, with separate frames and cams at each end of bars for lifting and pushing. These and the framework, as well as

parts of the whole machine, were only varied by increasing the weight and strength in every successive model, and this the firm continued to do up to the time of the introduction of their latest models.

A variety of springs to counterbalance the weight of lifting frames of the square motion were tried, and used for years, but they have since gone back for economy's sake to the old counterbalance weighted fly wheel on shaft which they had used in St. Denis in 1856.

They tried circle combs with three, two, and one row of pins, 30 pins per inch, 1-inch out of brass for Botany, and $1\frac{1}{4}$ -inch out for longer wools; and one with two rows with space sufficient between for the keeping plate to work inside of them; and adopted definitively the two rows of flat pins as close as possible to each other for strength—30 pins per inch. From 1851, as has been already mentioned, they had been gradually increasing the fineness of their working combs as well as circles. In January, 1858, they had at St. Denis, square motion working combs $1\frac{9}{16}$ (practically $1\frac{1}{2}$ push) with nine rows, 20 per inch; and in November, 1859, $1\frac{5}{8}$ (practically 2-inch push) with 16 rows, 20 per inch. They commenced their experiments at "Pennyoaks" with the first set of combs in August, 1861, with 16 rows of pins, 36 per inch. The breadth is not given, but it is supposed

to have been a 2-inch push. They tried a peculiarly formed set of combs, with the four front rows very close, back rows wider, 2-inch push, 11 rows, 36 per inch. Experiments were also made with 1-inch push combs, with 12 rows, 27 per inch, but they went back in September, 1863, to the $1\frac{1}{2}$ -inch push combs, 18 rows, 24 per inch; and from that date all Messrs. Holden's square motion combs have been $1\frac{1}{2}$ -inch broad, 18 rows, 27 per inch, except a few of 2-inch combs 24 rows, 27 per inch. Segment combs were tried with one, two, three, and four rows of different fineness, but they finally settled upon three rows, and sometimes four rows, of pins, 40 per inch, $\frac{5}{8}$ out of brass.

Many other valuable improvements were the outcome of the "Pennyorks" scheme. Carding was tried there on different systems of cards, and different degrees of load, with great care, and finally they adopted the card with three lickers-in of 20 inches, opening rollers of 18 inches, and doffers of 40 inches diameter. Numerous trials were also made in washing, with the result that at the Alston Works they adopted four successive baths, with feeding aprons working in sud bowl. They also improved the screw gill for drawing, and were the first to introduce the fine steel screw, $\frac{1}{4}$ -inch pitch.

Messrs. Isaac Holden and Sons closed the productive and laborious workshop of "Pennyorks" in 1864,

after opening their Alston Works. Indeed, by the terms of the arrangement with Mr. Lister, Mr. Holden was precluded from starting a wool-combing establishment in Bradford at an earlier date.

On the 5th of December, 1865, Mr. Holden took out a patent (No. 3123) relating to a most valuable improvement, whereby the tenuity of the sliver produced was so greatly increased that the coiler could be utilized, and the amount of hand labour required for supervision under the previous systems was enabled to be so much lessened that one woman could now do the work that it had previously taken several to perform. The strength of the sliver was increased by so manipulating the fibre in forming the sliver that the short fibres were worked into the centre of it, and the employment of the coiler being rendered feasible, this resulted in further improvement, the greatly increased regularity of the weight of each portion of the sliver, and consequently of improvement in the results attained in all the succeeding operations, extending into the spinning in a marked degree. These improvements too came at a time when the trade requirements were all for uniformity of slivers of top.

Mr. Holden applied a supporting table of wood under the supporting table formed by the endless leather belt which passes distended on rolls between the drawing off rollers and the delivery "tweedler," on

which rests the fibre being passed to delivery, the distension of the apron being completed for its return to its starting point by a tension roller below. The wood table under the leather is supported on springs for elasticity. As the fibre travels in a sliver on this travelling surface, it is subjected to the action of a mechanically operated rubbing instrument, which raises the edge of the sliver, rolls it into the interior, and, aided by the rotation of the tweedler which gives a twist, the fibres are more intimately mixed together and combined, enhancing the tenuity of the sliver.

Figs. 63 and 64 are respectively plan and sectional views of a drawing off apparatus with Mr. Holden's invention applied. The curved line *A* is part of the carrying circle : *BB*¹ are the drawing off rollers ; *C* the "tweedler" delivering to delivery rollers *DD* ; *E* the endless belt distended on and travelling around the course of the dotted lines (in Fig. 17) governed by the rollers *B*, *E*¹, *E*². *F* is the supporting table of wood below the leather travelling table *E*, and supporting it against the impact of the rubber *G*, as that is acted upon to produce a reciprocating and rubbing motion to rub or roll into the middle of the laid out sheet of fibres the shorter fibres which by the operation of the combs come towards the side of the sheet next the rubber *G* as seen on the plan, and by it are amalgamated with

the longer fibres, improving the average or uniformity of staple in any portion.

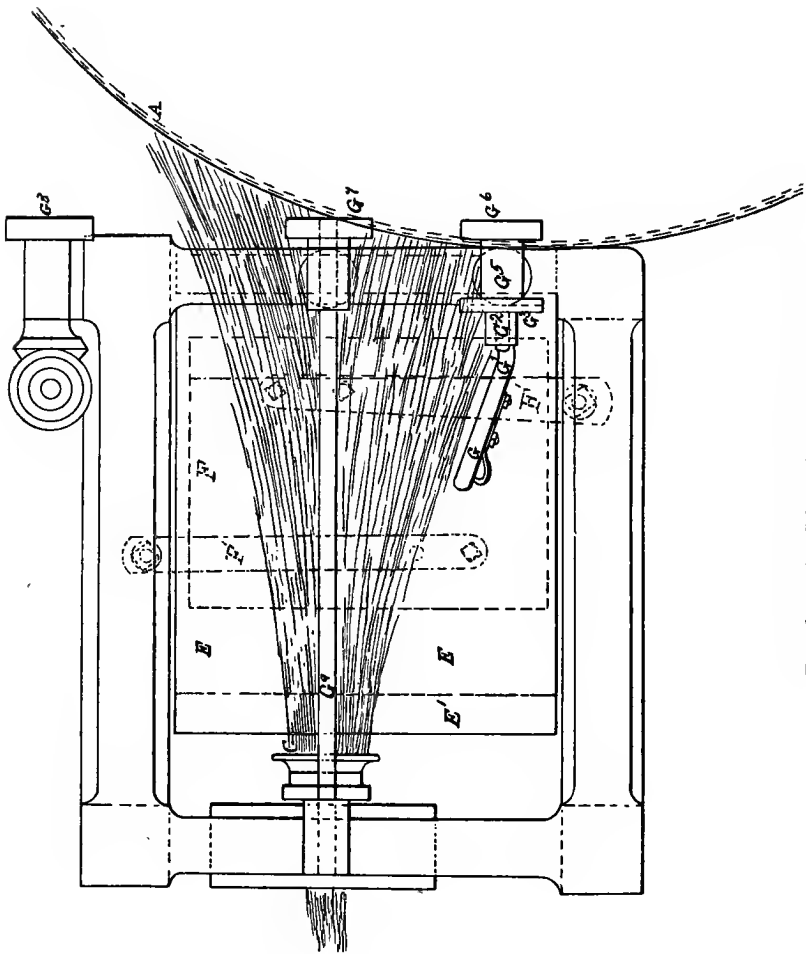

FIG. 63.—Plan View of Drawing-off Apparatus.

In summarising the leading features of the Square Motion machine, Mr. A. Lohren, in his work on *Die*

Kämm-Maschinen, makes the following remarks with reference to the feeding action and its effect on the sliver:—"As regards the filling-in or feeding ap-

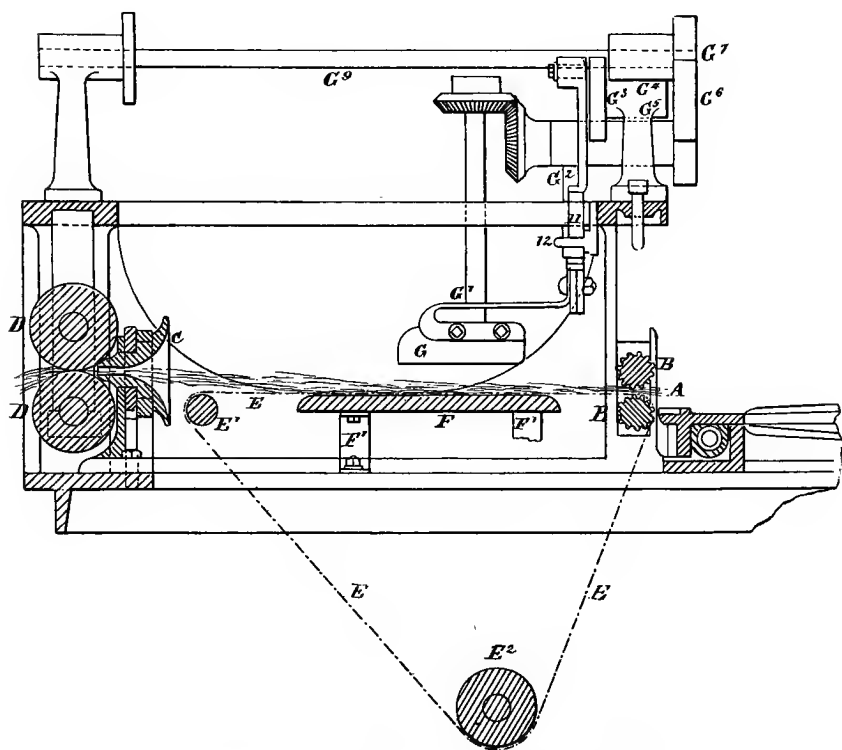

FIG. 64.—Sectional View of Drawing-off Apparatus.

paratus in Holden's machine, it is constructed to the present day according to the manifold undervalued principle of Cartwright's, which has often been declared to be the drawback of that system. It is in

principle an imitation of filling in by hand, and the objection against it is that the comb which has to be filled in this manner cannot receive the fibre without entangling and knotting the ends, so as to retain them firmly. It cannot however be denied that this method of filling in possesses certain advantages appertaining

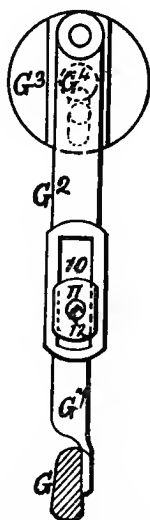

FIG. 65.—End View of Rubber.

to no other feed apparatus, the first and foremost being that it effects a perfectly regular feeding or filling in without necessitating a very carefully condensed sliver, the material being capable of being used without so much previous preparing as is required by other kinds of feeding apparatus. All of the better class of comb-

ing machines require slivers which not only have to be well carded, but have also to pass through three or four screw preparers to give them the regularity and parallel position of the fibres which is requisite for a good working effect. Every preparer, however, not only diminishes the strength of the fibre, but also causes extra waste and expense. The old apparatus requires nothing of the kind. Holden, with his great practical clear-sightedness, has so constructed that he can not only use any kind of sliver, but even loose masses of fibre, and still effect a perfectly regular filling in into the comb ring. This fact explains why he can comb materials which are rejected by all other combers, and can extract the long fibre from fibrous substances which others cannot work at all."

Mr. Holden further increased the efficiency of the Square Motion combing machine in the patent of 1856, by—amongst other improvements of great utility at the time, but not now so prominently noticeable—further alteration of the mode of driving the carrying comb circle, having the rack of teeth provided on its outermost or peripheral face, with regard to which the previous patent, No. 1890, gave description. In the present patent the driving screw acted intermediately on a double stud wheel, which turned the circle by the engagement of its teeth therein, as shown by Figs. 66 and 67, K being part circle of carrying combs, K¹

being the teeth of the rack on the under rim thereof.

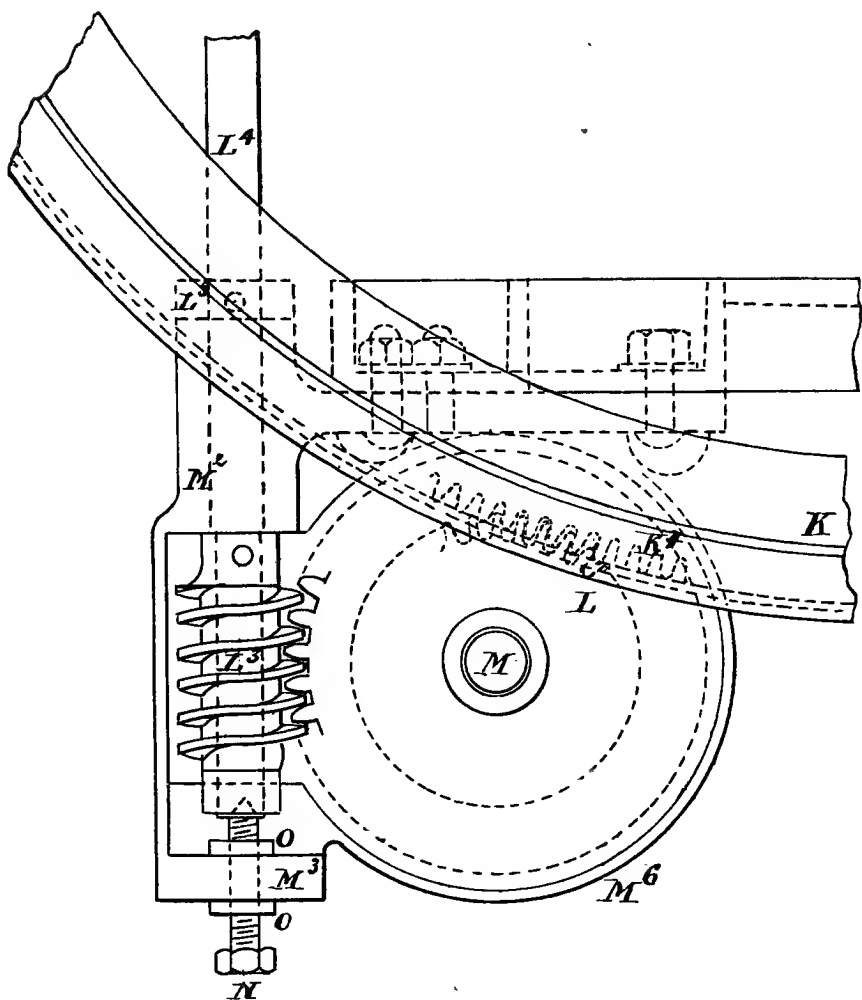

FIG. 66.—Motion to Circle of Comb Teeth.

Into these teeth K^1 engages the stud wheel L, which

is mounted on an axis common to itself and to a screw wheel L^2 , these two wheels, L, L^2 , by their boss L^1 being made one rotative piece, and the screw wheel L^2 being driven by the worm or screw L^3 on the axis L^4 , the circle is rotated and can be better driven and the parts easily lubricated.

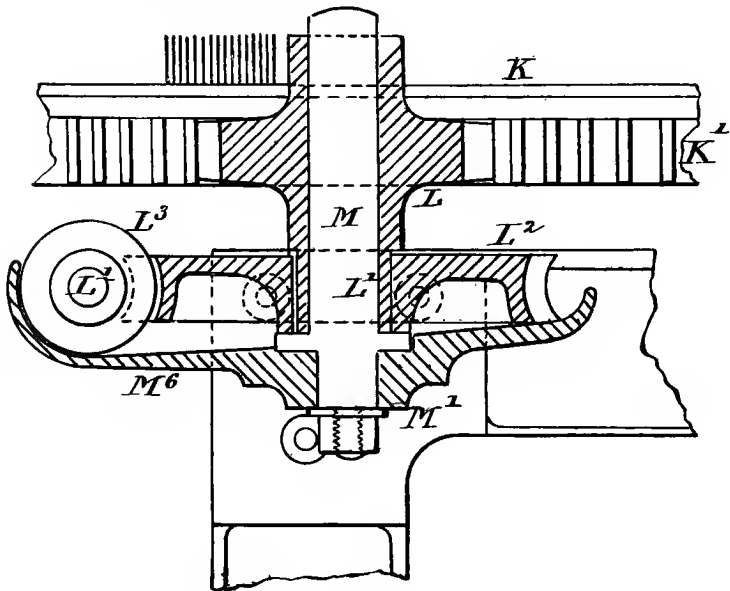

FIG. 67.—Sectional View of Same.

On the 21st October, 1868, by patent No. 3219, Mr. Holden put on record a further invention, relating to the use of a guard plate, formed with a projecting ledge, and extending from the point of tangence of carrying circle and drawing off roller to where the long

fibres begin to be drawn through the two combs ; it also extended some distance in the opposite direction, and a part of it acted to stop off draught of top from the carrying circle.

Fig. 68 illustrates this useful and simple device. *A* is the guard plate, *B* the carrying comb, and *C* the "nacteur" comb. *a* is a projecting ledge to plate *A*, which in working gives support to teeth in combs *B* at the drawing off of fibre through those teeth and through teeth *C*, by the rollers *D*. The projection *b* affords similar protection to the teeth of *C*. The part *c* of plate *A* is that which acts to stop off the draught of top from the circle. The part *d* of the guard plate *A* is recessed to allow the lower of the drawing off rollers *D* coming closer up to the main circle.

During more recent years various other improvements have been effected in the Square Motion combing machine, but the record of patents which we have endeavoured to summarise represents the leading features of the machine as it exists at the present day. Its primary principle is that it is a perfect imitation of the mode of working of the handcomber, and the work it accomplishes resembles that of the handcomber. It produces the same polish, the same curl or crochet, the same softness and loftiness, and the same high spinning qualities, the length of fibre in top and noil being well preserved.

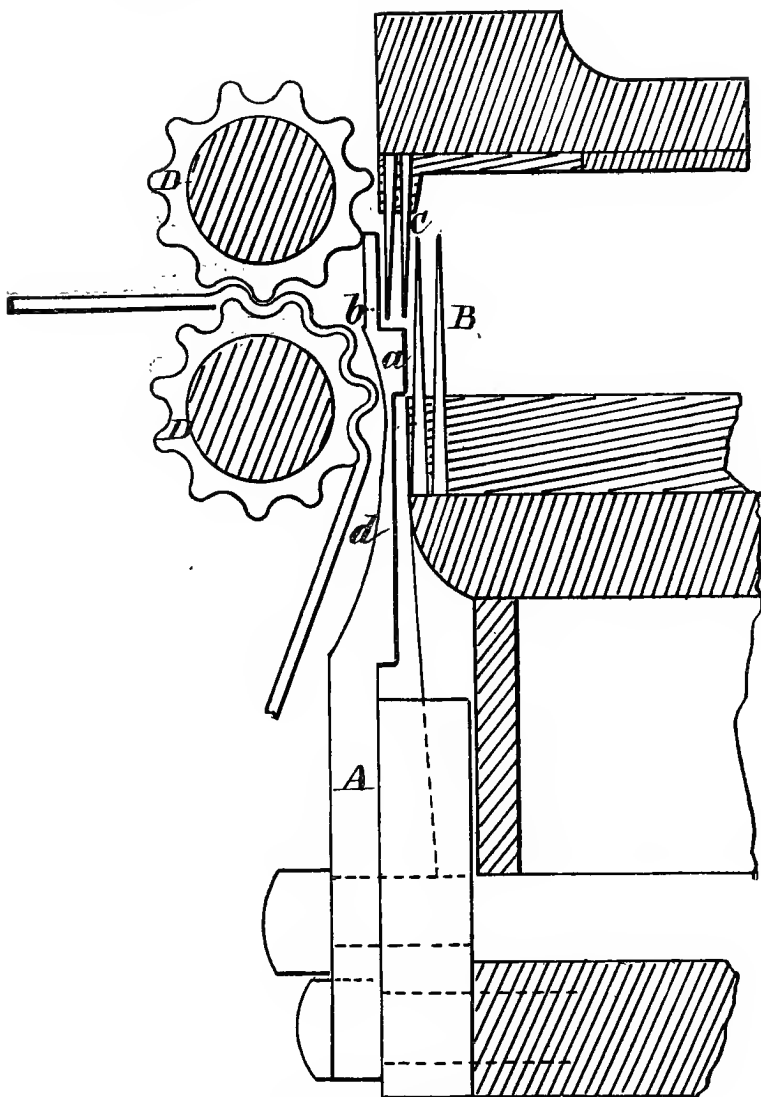

FIG. 68.—View of Guard Plate.

Apart from this one piece of mechanism, however, Messrs. Isaac Holden and Sons have contributed largely to their success as woolcombers by the admirable adaptability of their works to the various processes. There are two preparatory operations which occupied Mr. Isaac Holden's careful attention from an early period, viz. those of washing and carding. Mr. Holden was the first in the trade to use two successive baths and rollers in the washing of wool. This was at St. Denis. It soon became universal in all woolcombing establishments. No patent was taken out for the improvement, however, although it formed the legitimate subject of a patent, being new, original and useful. A third process was added and patented in January, 1857 (English patent No. 278), along with three steeping baths, mounted on wheels, and moved in and out of action on rails. This plan is still continued with advantage under certain circumstances. Mr. Holden had always been in favour of still further extending the operations of washing, and at the Alston Works, in 1864, they adopted four operations. At Croix it was found advisable to submit the wool to five washing processes, and all the newer part of the works was mounted in 1865 in that manner with great advantage.

The important process of carding was first used by Mr. Holden as a preparation for combing at Culling-

worth in 1837, and in consequence of a declaration to that effect by Messrs. Townend, an action for infringement by Mr. Sellière against Messrs. Holden in France was stopped. Mr. Holden was also the first to adopt two lickens-in with opening rollers. The firm of Lister and Holden started all their cards on this plan at St. Denis, and having worked them privately until 1857, Mr. Holden patented the method in that year. At "Pennyoaks" and at Alston, a third, and, later, a fourth was introduced with success, Mr. Holden at the same time increasing their size to 20 inches, the opening rollers to 18 inches, and the doffers to 40 inches diameter with special success.

At the suggestion of Mr. Daniel Bateman, of Bradford, a burring roller was added to the lickens-in in 1860-61. Mr. Bateman had first applied this apparatus to the cards of his brother-in-law, Mr. Wade, at Morton, who had very dirty wools, choked with thistle tops and burrs, to card, and there they found the roller most useful. On visiting Croix and Rheims, Mr. Bateman urged the adoption of this invention at those establishments, where they have always had wools to comb containing burrs and thistle heads, and he supplied a number of the rollers to Croix, which proved of excellent service. At that time the wools at Rheims and Alston were almost entirely free from burrs, but of late years burry wools have found their way to

both places, and burring rollers have had to be introduced at all the establishments, and are now found indispensable, even for Australian wools, which each succeeding year come to market with more and more burrs.

This may not be the time exactly in which to take the full measure of the work which Mr. Isaac Holden, and those who have been associated with him, have accomplished in the perfecting of wool-combing on the principle adopted by them, still as to the broad results and the general manner of their achievement it is impossible to withhold a proper recognition. Success was obtained, in the first place, by the employment of a machine of special excellence, and secondly, by pursuing the best methods of harmonious and effective working. Mr. Holden did not engage himself in personal direction beyond the general organisation and control, the investigation of defects, and the suggestion of means of remedy. He therefore at an early period occupied himself with much thought and close observation in the choice of managers. The qualities he sought were personal devotion, integrity, industry, organising power, and tact in dealing with workpeople and clients. He also learned from his own early experience the wisdom of giving to responsible managers much liberty of action, and a strong personal interest in the work of manage-

ment. Machine combing, and the creation of the vast establishments in which it has been carried on by him and his partners so successfully and so lucratively, seem to have been the dream, the study, and the work of his life. From the first, he decided to make wool-combing his exclusive and favourite pursuit, and in following it through all its stages has found it a source of the greatest pleasure and satisfaction. From his first introduction to the work in 1830, he disdained remaining a book-keeper, a spinner, a manufacturer, or even a genappe maker, tempting as the prospect was to him at one time as the inventor of the now universal method of making genappes. He resolved to be a comber. He pursued that object with un-deviating and dogged perseverance, and stuck to it amidst harassing discouragement and opposition, with hazardous enterprise at certain stages, and laboured hard at it for some thirty years before he found it really productive. Most men would have relinquished the struggle long before this turning point had been gained. Not so Mr. Holden. He saw in it an object worthy of his industry and sacrifice, and he knew that success meant an honourable, a privileged, and a highly profitable business to its projector, and that at the same time it would prove an inestimable boon to society, and especially to the trade with which it was connected.

It is not a little remarkable that since the Square Motion patent of 1856 no other invention of the first importance has appeared on the scene, and as the machine of 1856 would now be perfectly useless, as would also all that preceded it, owing to the great progress which woolcombing has since made, Mr. Holden has good claim to be regarded as the author of the Square Motion machine now existing. At the same time, those who have been associated with him have rendered important service in the work of its practical development, and will not fail to receive their share of recognition.

CHAPTER XIV.

THE NOBLE MACHINE.

WE now arrive in the natural sequence of our history at the interesting period which gave birth to what may be styled a new and distinct order of woolcombing machine, representing a mechanical principle differing in essential points from the other classes of machines which we have described. This machine is called the Noble, from the fact that the letters patent for it were taken out in the name of Mr. James Noble, although, as we shall show, that gentleman was not on that account entitled to the full merit of the invention. The mysteries of the Patent Office are unfathomable, and the instances in which inventions are patented in the names of men who had little if anything to do with their evolvment are but too numerous.

As early as the year 1805 we come upon the name of James Noble in connection with woolcombing inventions ; yet, strange to say, it was not until some half a century afterwards that the particular machine was

invented with which his name is especially associated—that in which what is known as the Noble principle was first brought into operation. Noble was a working mechanic of a strong inventive turn, whose early years were passed in the manufacturing districts of the Midlands. When he first directed his attention to woolcombing the trade was struggling with Cartwright's machine. Noble's invention of 1805 had relation to "a machine for discharging a wool comb or combs by separating the tear from the noils and drawing what is commonly called a sliver or slivers from the comb or combs, after or before the combs were worked or the wool was combed upon the same."

Twenty-eight years later, in 1833, he took out a further patent in connection with woolcombing, but no specification was enrolled. In the following year he again appeared at the patent office and obtained protection for certain improvements in combing wool. In this machine the first noticeable part was a bar of wood or "lever" situated within-side the frame, with a back and forth motion, given by a crank and wheel at the back of the machine. It had likewise an up and down motion imparted to its front end by an eccentric wheel placed in advance of the lever's bearings. At this end of the lever were the heckle needles, points downwards. At the front end of the frame was another set of needles, points

upwards, fixed to a carriage moving backward and forward, worked by a spur wheel and a worm fixed on the end of a light shaft turned from the driving axle of the machine, then by the combined motions of the lever, the heckles of which were charged with the wool, acting against the heckle needles, working backward and forward underneath, the wool would undergo the operation of combing. Another section of the patent was shown where the last plan of working the needles was superseded by rows of needles set obliquely on the periphery of a drum, that form being best adapted for combing long wool. In the specification it was observed that in using the machine the combs or needles were to be heated in like manner to those of hand-combing.

In 1836 Mr. Noble patented further improvements in woolcombing machinery. In the centre of the machine was a rotary comb carrier, or axle, provided with arms at whose extremities were fixed the combs, set in tables or frames; the ends of these bearers moved in eccentric guides or grooves fixed to parallel plates or the sides of the machine. The feeding comb was made to advance gradually on a moveable table towards the rotary comb carrier until the wool upon it became exhausted, when it was returned for another supply.

Another long interval of time elapsed between the

taking out of the last-mentioned patent and the re-appearance of Noble on the scene as an inventor. In 1846 he was at Leicester taking part with Mr. John Perry in patenting a method of combining a circular carrying comb with a circular working comb, and of retaining wool in the revolving combs by a plate or stop when being worked by combs.

About this period Mr. Noble became associated with Mr. Donisthorpe, and in 1853 was taken out the patent for the machine which was thenceforth to be known as the Noble machine, and which represented a creative effort of no ordinary importance. Mr. Donisthorpe was at that period precluded, by the terms of his arrangement with Mr. Lister, from bringing forward any woolcombing improvement on his own account. Otherwise, it is generally understood and admitted that Mr. Donisthorpe's name would have been joined with, if not substituted for, that of Noble in the patent of 1853.

In a letter to the *Bradford Observer* of the 18th of February, 1875, a correspondent signing himself "Amicus," and understood to be the late Mr. George Thompson, formerly M.P. for Tower Hamlets, makes special reference to Mr. Donisthorpe's connection with the Noble machine, and as the testimony may be regarded as that of one who knew what he was writing about, we may accept it as sufficiently authoritative

for our purpose. "It is a strange and significant fact," "Amicus" wrote, "that both Mr. Donisthorpe's principal combing machines bear the names of others, one (Lister's machine), . . . the other (Noble's), for the following reason, which is highly creditable to Mr. Donisthorpe's sense of honour. Noble having conceived the ingenious abstract principle of two circles working one inside the other, but being utterly unable to design a workable machine upon it, came to Mr. Donisthorpe, who at once appreciated the idea, and the same night invented the well-known machine. Instead of taking out a patent for it in his own name, or even of coupling his own with Noble's, he himself paid all expenses, and enabled Noble, who was a poor man, to patent the machine and act independently. Subsequently, it is believed, he re-purchased his own invention for an annuity." Nothing is said or hinted by "Amicus" concerning the terms of Mr. Lister's understanding with Mr. Donisthorpe, but there is little doubt that they were of a nature to at all events seriously interfere with Mr. Donisthorpe's independence of action as far as regarded woolcombing inventions. Nor is there in this anything derogatory to Mr. Lister. He had paid Mr. Donisthorpe a very large sum for what was of little value, except as the foundation of a more perfect machine, and without some hold upon his services in maturing the invention, Mr.

Lister would have made an exceedingly bad bargain. Besides, it was only to be expected, and in accordance with ordinary business dealings, that in venturing his fortune and future upon this particular enterprise, he should take measures to protect himself from the possibility of having to reckon with his co-inventor as a business rival.

The Collier machine was the first which accomplished the combing by two revolving comb rings, but it did not have the filling-in process performed at the point in contact, but at any point of their circumference at pleasure. Lohren remarks that, as regards the action of two revolving rings of pins upon each other, it is easy to perceive that there can be no simpler means of combing a fibre at both ends than the filling in of the fibre into two tangential rings of pins. For if both rings revolve in the same direction and with the same speed, it necessarily follows that one portion of the fibre is carried off by one of them and another portion by the second one, whereby the drawn out ends of the fibre are combed and the noils and impurities retained between the pins. If the projecting fibre ends are then drawn out by drawing-off rollers from each ring, two slivers are produced, in which the fibres have been combed at both ends. This simple original idea was first recognised in the Noble machine of 1853. Two comb rings were selected of a diameter

only slightly differing from each other, of which the smaller touches the larger at its inner circumference. It is impossible to fill in fibres by mechanical means in the short space of a few mathematical points, or in a very short line; where the rings are touching each other it is necessary to fill into both at the same time, thus avoiding placing a portion of the fibres into the interstice after the two rings have already partly separated. Preference had to be given to the two rings touching each other internally, as producing a closer and longer space of contact than when placed in a tangential position where the separation takes place much sooner.

Noble's principle however became only of real importance for machine combing after the introduction of the peculiar feed apparatus introduced in 1856 by Tavernier, Donisthorpe and Crofts, and by its admirable construction by the firm of Taylor, Wordsworth and Co. of Leeds. In this shape it was largely adopted, and is one of the leading combing machines now in use, being more especially adapted for short and medium wools.

The invention of 1853 consists in combining two rotating rings of combs one within the other, but eccentric thereto, so that at one point of the revolution of the rings they come together. The inner ring gives motion to the outer one, by being furnished

with a toothed rim on its external circumference, the teeth of which gear (where the rings are nearest together) into those of another toothed rim on the inner circumference of the outer ring. Motion is given to the first ring by suitable gearing from the driving shaft of the machine. Above the rotating rings of combs and on the axis of the inner one is a circular frame carrying bobbins of prepared material, which descends from the bobbins and passes between two curved surfaces or instruments carried by levers suitably supported and carried round with the inner ring of combs, by which, with the aid of circular and the ordinary lever brushes, it is deposited upon the combs just before the two rings come together. So soon as the rings come together the fibres are drawn by drawing rollers from between the teeth. As the distance apart of the two revolving rings increases, the long fibres remaining therein will be retained in the teeth of one of the rings, and the teeth of the other ring will retain the shorter fibres, which are removed by a brush. The longer fibres, so carried round, are lifted out of the teeth and again placed into the teeth of the two rings, and come again to be drawn off by the rollers. The curved surfaces which conduct the material from the bobbins, are mounted upon levers, which also carry the circular brushes for assist-

ing to deposit the material upon the combs, and the curved surfaces are made to press upon the material, as requisite, by being connected to springs, and the levers being acted upon by a fixed curved surface during their revolution with the rings.

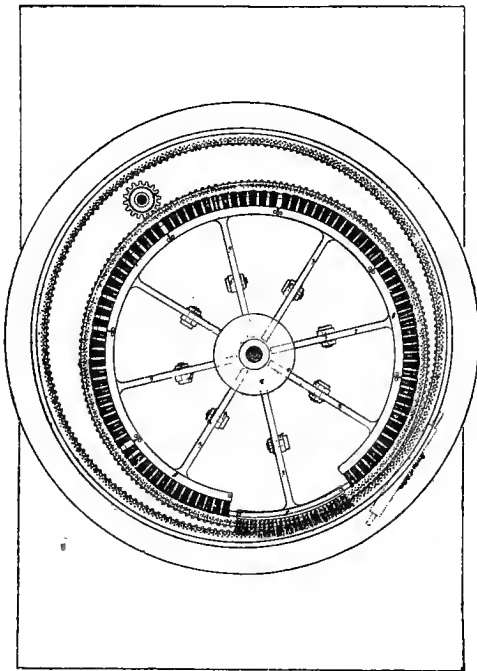

FIG. 69.—Plan of Noble Comb-rings.

Fig. 69 shows a plan, and Fig. 70 a transverse section, of apparatus suitably arranged for effecting the improvements included in the Noble machine. In referring to these drawings, it was stated that, the

nature of this description of machinery being so well understood by persons engaged in manufactures, it

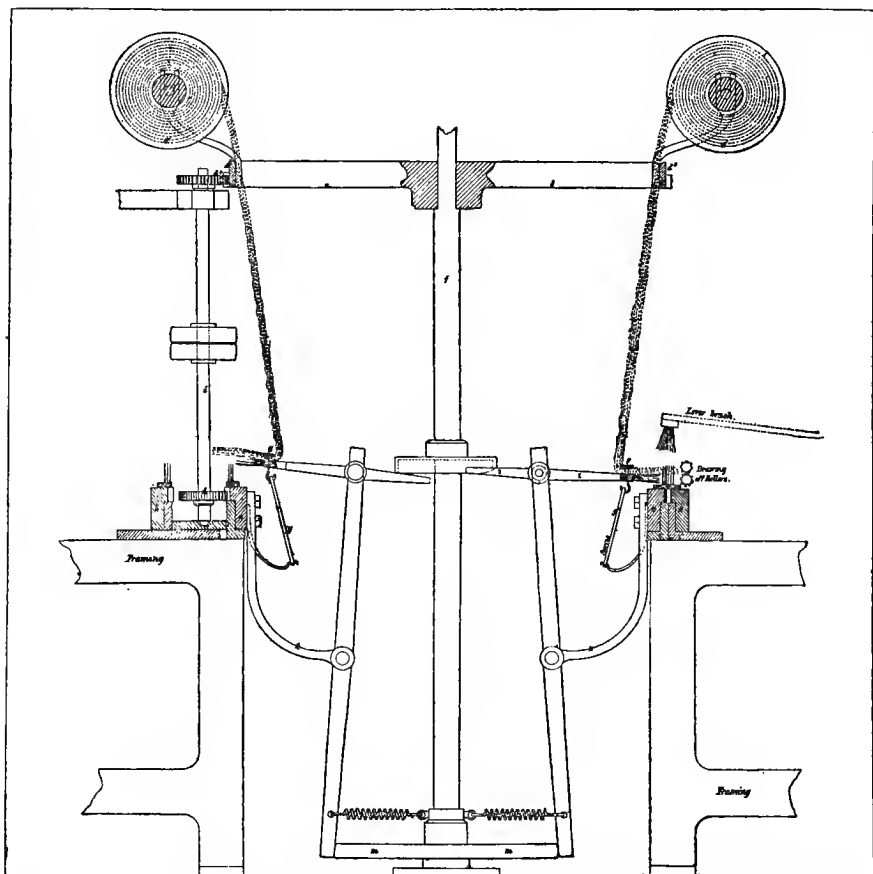

FIG. 70.—Transverse Section of Noble Apparatus.

had been only thought necessary to show so much of a machine as would enable a competent workman to

understand the improvements then introduced. The description appended was as follows:—*a*, *b*, are two rings of comb or suitably formed teeth, which revolve upon the fixed bed or table *c*; the ring *a* revolves within the ring *b*, but is eccentric thereto, so that at one point of their revolution the comb teeth upon the rings *a*, *b*, approach towards and then recede from each other. The rings *a*, *b*, are caused to revolve in the following manner: *d* is a pinion, carried by the vertical shaft or axis *d*¹, supported by suitable bearings on the bed or framing of the machine, and the axis *d*¹ receives motion by a strap or otherwise from a steam-engine or other motive power; the pinion *d* takes into and drives the toothed rim formed on the outer circumference of the ring *a*; the teeth of the ring *a* take into and drive the toothed rim formed on the inner circumference of the ring *b*, at the point where the two rings come together; *e* is a circular frame, carried by and revolving freely on the fixed vertical axis *f*; the frame *e* carries the bobbins *e*¹, of prepared cotton or other fibre, which is conducted from the bobbins between the curved surfaces *g*, *h*, carried by the lever arms *i*, the levers *i* being supported by pin joints at the upper ends of the levers *j*; and the levers *j* are supported by arms *k*, fixed to and carried by the inner circumference of the ring *a*; each of the curved surfaces *g* are connected to the curved surfaces *h*, by

pins at each end of the surfaces g , passing through holes in the ends of the surfaces h , and the pins are connected to the spiral springs g^1 , so that when the outer ends of the levers i , and surfaces g , h , are raised by the action of the fixed cam surfaces l , on the levers j , the two surfaces g , h , will be drawn together, and will hold the cotton or other fibres between them, whilst they are moved outwards by the action of the fixed cam surface m , or the lower ends of the levers j ; at that part of their revolution where the rings a , b , approach each other, the lower surfaces h have brush surfaces projecting therefrom, by which the cotton or other fibres are raised out of the teeth of the ring a , and are carried forward into a position over the teeth of the two rings a , b , just previous to the point where they come together; and the cotton or other fibre is then pressed down into the teeth of the two rings by a brush carried by a lever, as is well understood. The ends of the fibres projecting from the teeth of the ring b , in their further revolution come in contact with and are drawn off by the drawing-off rollers n , which are of the ordinary description. The rings, in their further revolution, will separate, and the noil or short fibres will be left in the teeth of the ring b , and may be removed by a brush or otherwise; the long ends of the fibres retained in the ring a , having been drawn through the teeth of the ring b , will then be raised or

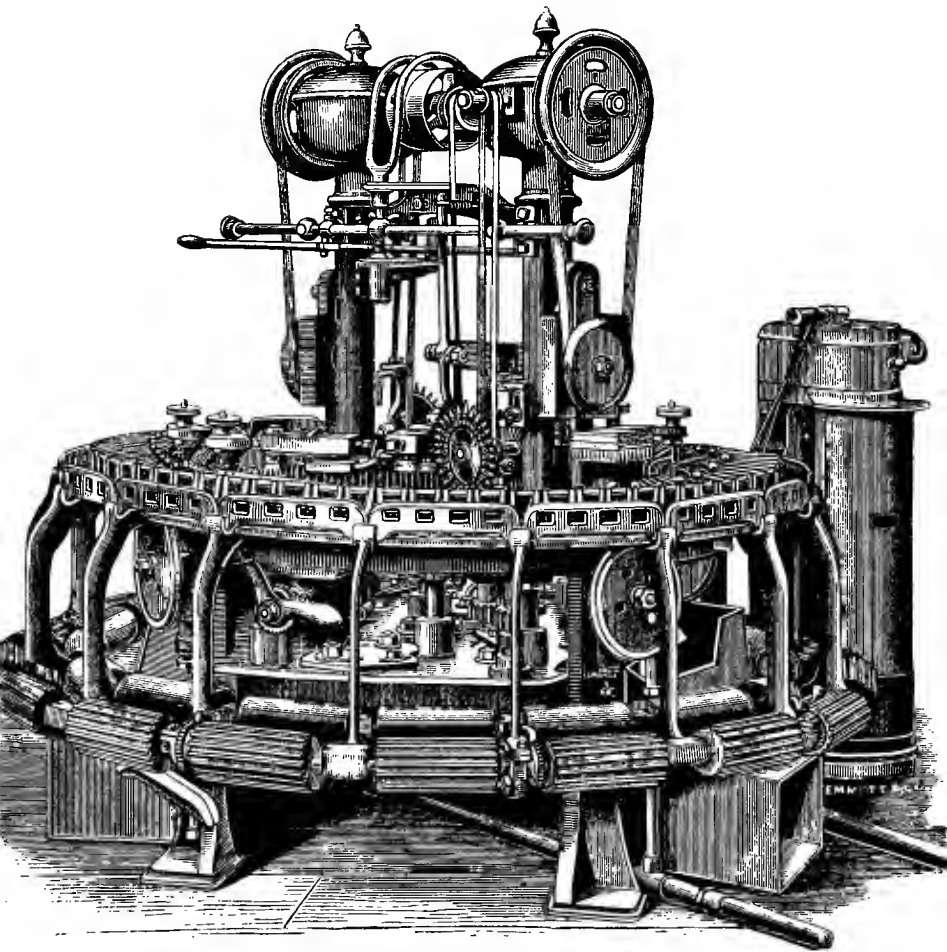

FIG. 71.—General View of the Noble Woolcombing Machine.

lifted out by the action of the cam on the levers *i*, and curved surfaces *g*, *h*, and be again placed over the teeth of the two rings where they approach each other, and so on in succession. The frame which carries the bobbins of prepared cotton or other fibres revolves at the same speed as the ring *a*, and receives motion from a pinion d^2 , fixed on the upper end of the axis *d*, which takes into the teeth of the ring d^3 , carried by the frame *e*.

In order fully to understand the structure and action of the Noble machine as it exists to-day, it is necessary to institute a closer comparison between its working and that of the other leading machines. We cannot do this more clearly than by following Mr. McLaren, who has given a very lucid description of a Noble machine in his practical treatise on *Spinning Woollen and Worsted*. Comparing it with the nip, he points out that instead of the wool being put up at the back of the comb, it is wound on to large bobbins, and placed in the circular rack which surrounds the centre of the machine. These balls are made on a special balling machine being made quite hard, without any twist being imparted, so that when they are transferred to the creel of the comb they can be unwound just as they lie, and the ends can be drawn into the circles for combing. Eighteen of these balls constitute a set, and they are placed on the rollers of the comb, with

their ends through the rings, in succession all round ; the ends then pass through the patent feed boxes invented by Mr. Whitehead, a member of the well-known firm of combing-machine makers, Taylor, Wordsworth, and Co. These feed boxes are made of brass with a heavy lid, the end at the back being open, but the other being closed when they are empty. As the hinge of the lid is at the back, all its weight falls on the other end, and the wool is thus held somewhat firmly, and cannot slip backward unless the lid is opened. "There are seventy-two of these boxes, and, as will be seen, they are set in a ring. Inside this ring is a large circle, which rests on a circular steam chest to heat it ; and the whole of this portion of the comb, except the steam chest, namely, racks, rings, boxes, and large circle, revolve together. Inside the large circle are two small circles, one at each side, and the whole combing is done by the motion of these three circles relatively to each other. The large circle is usually 48 to 60 inches in diameter, and the small ones 16 to 20. The width of the rim of these circles varies according to the class of wool to be combed, but in the large circle it is usually from 2 to 4 inches wide, and in the small ones from $\frac{3}{4}$ to $1\frac{1}{2}$ inches. They are covered with rows of pins set in circles round them, and the size and number of the pins vary likewise according to the wool. For fine wool the front rows of pins in the large

circle may be about 40 per inch, and in the small circles 44, while the rows at the back are coarser. For strong wool, 18 pins per inch are enough for the large circle, and 20 for the small ones ; but these numbers vary indefinitely. The three circles all move in the same direction, but the small circles merely touch the large one at one point, and revolving leave the latter behind. It is this which combs the wool. As the carriage, *i.e.* the boxes, racks, and large circle revolve, the wool is brought to the point of contact of the large circle and one of the small ones. By a motion to be described presently, the wool is constantly being pulled through the boxes, so that it projects over and beyond the large circle. Therefore its ends project over the small one. Just as it passes over this point, a dabbing brush falls on it and presses it down into the pin of both the circles, where, of course, it must remain. The little circle, revolving, draws from the large one as much wool as it is able to retain of that which has been dabbed into it ; that is to say it takes all the noil and short wool from the large circle out of the particular piece of sliver which has been dabbed in at any given moment. It leaves projecting from the large circle the ends of all the fibres of the long wool which, owing to their length, have preferred to remain behind ; but in doing so it combs this projecting portion. As all the ends of the sliver have

been dabbed into the little circle, and as this latter in revolving has been obliged to leave the long fibres in the large one, they must all have been drawn through the pins of the little circle, and the noil that may have been in them has been retained there; so that the ends which project from the large circle are quite clear. Similarly the ends which project from the outside of the little circle must also be made clear, because they have been dabbed into the large circle, and have been drawn through it as the little one leaves it. Thus the projecting fibres which remain in the large circle have left their noil in the little one; and those which project from the little circle have left their noil in the large one, and the projecting fibres in each are combed clear. We will follow the little circle first. The wool in it now consists of short fibres, which are yet long enough to be used in the combed wool or top, and the very short fibres which form the noil. As it revolves it is met by the stoker, a wheel with sharp teeth projecting from it, and screwed on to it." These teeth, by another patent of Mr. Whitehead's, can all be moved together, and set at any angle that is required. "The wheel revolves from left to right, and is used to stroke the wool which projects from the little circle, so as to turn the ends forwards instead of letting them stand straight out. To do this it must revolve very rapidly. As soon as the wool has passed this it is met by a

small pair of vertical drawing-off rollers, which catch all that projects, and draw it out of the circle, combing as they draw the ends which were formerly in the pins. What remains in the circle is noil, and is lifted out of the circle by knives, which are set between rows of pins. The noil ultimately tumbles over into a can, and is removed. The large circle in the meantime is travelling on, with its long wool projecting from it. It soon comes to a travelling leather apron, which goes quickly, and draws the points of the wool forward, acting like the stoker to the little circle." The drawing-off rollers are now approached, and the leather passes round one of them. These draw off all the wool they can catch, and it passes along between another part of the first leather and a second leather, "until it meets the short wool sliver which has been drawn from the little circle, and the two then unite. As the second little circle has been acting in the same way all the time, there are thus two ends of short wool and two of long, all of which join together," pass up a steel funnel, which puts a little false twist into them, and then through a pair of press rollers, into a long brass funnel which carries them into a can set to receive them.

"Such," Mr. McLaren adds, "is the principle of Noble's comb. It is, in brief, merely dabbing a lock of wool on to two sets of pins placed close together,

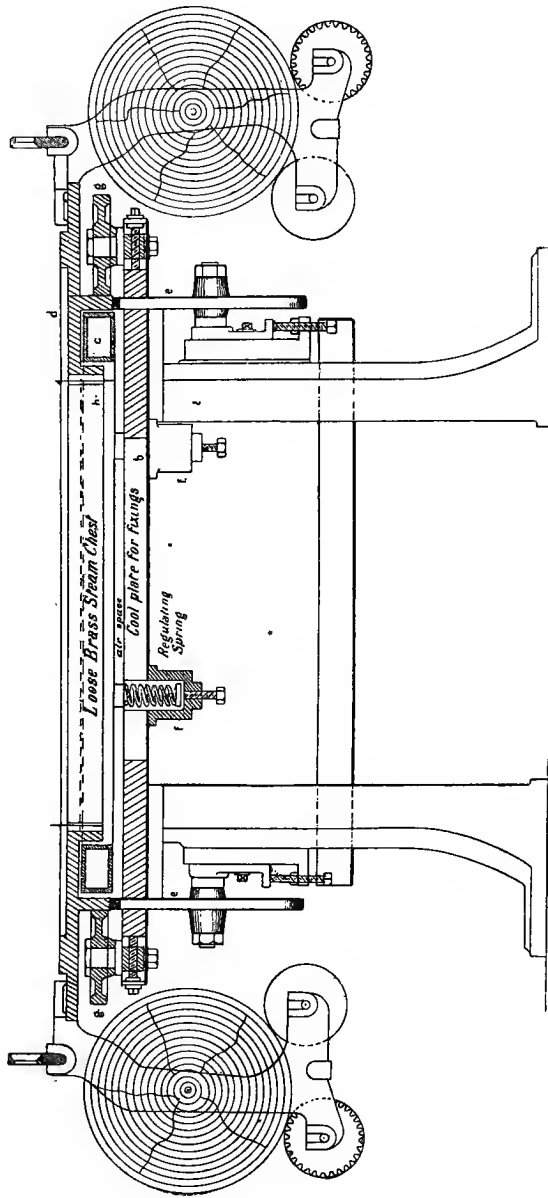

FIG. 72.—Whitehead's Noil Conductors.

then parting the two sets so that a portion of the wool adheres to each, afterwards drawing the wool out of each through the pins, and again uniting the wool thus drawn to make the combed top. The arrangement of the various parts is somewhat more complicated than in the nip comb, though the relative adjustments are not so delicate."

Numerous improvements however have been effected in the working of the Noble woolcombing machine in recent years. Amongst these should be particularly mentioned the alterations introduced by Messrs. Taylor, Wordsworth and Co., who have been identified with this form of machine from its origin. Indeed, this firm have kept well abreast of contemporary inventive effort in all the operations connected with woolcombing on the Noble system, and hold sixteen separate patents for improvements.

The earliest of these, brought out in 1874 and 1876, relate to the conducting of the noil from the small circles without the use of noil rollers, leaving the noil loftier and effecting a considerable saving. These were the invention of Mr. H. Whitehead, a member of the firm. In 1878, Mr. C. Whitehead introduced a patent Sheet Conductor, which was found to be of great utility in preventing stoppages and piecings in the slivers. A Spring Feed Knife and sliver guide were added by Mr. J. H. Whitehead in 1882, for which

is claimed the advantages of easy regulation, the same height being always kept in front, thus preventing any extra pressure on the wool when the knife is altered for different feeds. In regard to the dabbing brushes, fresh arrangements of value have been brought forward not only by Messrs. Taylor, Wordsworth and Co.,

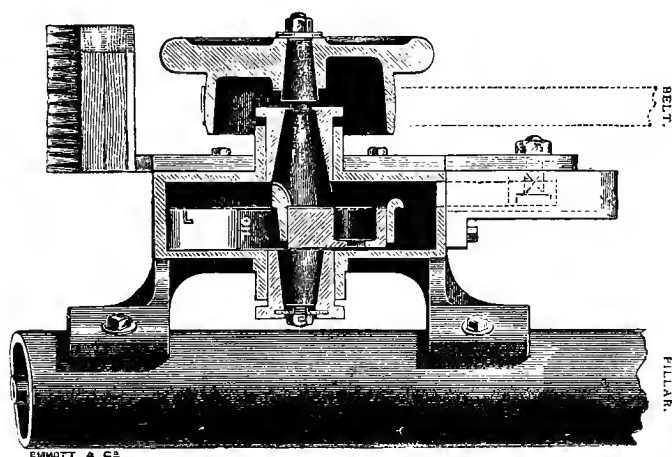

FIG. 73.—Lister's Self-lubricating Dabbing Motion.

but by other inventors. Lister's patent Self-Lubricating Dabbing Motion represents an improvement which Messrs. Taylor, Wordsworth and Co. have adopted for attaching to the Noble machine. By its application, the brushes can run up to a thousand dabs per minute if required, and the better dabbing of the wool into the pins is secured. As its name implies, it is self-

oiling. A Rack Circle, patented by Messrs. Pickles and Whitehead in 1887, also deserves attention. By its means the circles can always be run true, and the friction is greatly reduced. Messrs. Holden, Burnley and Co., of Bradford, also made a decided step in advance by their invention of a Stop Motion, the effect of which is to prevent laps on the drawing-off rollers, and to stop the machine on the breaking of an end.

The Noble machine, like the Square Motion, has from the first engaged the skill of many minds in remedying its original faults; and the work of improvement is still continued with vigour and earnestness. Speight's Patent Motion, by which speed is gained from the top pulley to the bottom one by a belt, and by an eccentric motion, was of excellent service; and Messrs. Hoyle and Preston simplified matters by inventing an effective method of working the brush entirely by a revolving plate or wheel, which, while giving a vertical motion to the brush, gives a rotatory and partly horizontal motion to the rod attached to it.

Yet, in spite of persistent inventive effort each combing machine, of whatever class, has its own particular drawbacks and defects; and the Noble machine can only deal with prepared, and not carded wool. A "second fault is," to quote Mr. McLaren,

“that there must always be a very small space between the two circles at the point where they meet, the brass plates the pins are set in may actually touch, but there is sure to be a small space between the pins of each. For very fine work the evil of this is that the small part of the sliver which is dabbed between the circles never gets combed at all, and may contain noil knots.” Another fault is that “the less noil there is made the less weight of wool is combed.” These defects have been dealt with, though not overcome with absolute success, by numerous inventors in England and France. The chief aim has been to effect the proper combing of the middle portion of fibre by means of intersecting combs. Geller, Whitehead, Bradley, Lohren, and others, have all done something towards this end, and the Noble machine has to a large extent supplanted the machines of the nip order, the latter only being used now for long English wools.

The Noble machine, with its later improvements, occupies a prominent position in the woolcombing world, and the very large extent to which it is used is a sufficient proof of the esteem in which it is held by the trade.

CHAPTER XV.

SUMMARIES, COMPARISONS, AND CONCLUSIONS.

HAVING traced the growth of the essentially modern art of machine woolcombing from its first practical inception in the mind of Dr. Cartwright down to its more recent development, and having described the leading principles and features of those woolcombing machines which have contributed most materially to the splendid results of to-day in this special branch of industry, it will be an interesting task to attempt to set forth, by comparisons and conclusions, how the record of woolcombing stands at the present time.

The calling of the handcomber long since disappeared from the face of the earth, and after his supercession it only remained for the inventors to fight out their battle for mechanical supremacy. There being so much at stake, there were many competitors for the prize, and, as we have shown, the contest was of long duration, involved the expenditure of many fortunes, was most keenly and vigorously prosecuted,

and culminated in an inventive triumph which can only be compared in extent of utility and wealth-creating power with the grand creative efforts of the remarkable men who, by a series of inventions of the highest order, lifted the cotton trade of Lancashire from the rank of a cottage industry to the broader plane of commercial vastness represented by the establishment of the factory system.

Some few foresaw that the introduction of machine woolcombing would have the effect of strengthening our hold upon the textile arts, and that although it might for a time increase the pinch of poverty amongst a certain class of workers, the ultimate benefit it would yield to native industrial enterprises and to the community generally would more than counterbalance any temporary disturbance of the handcombers' prospects. But none could have predicted the real magnitude of the change that this machine was to bring about. The course of events had gradually paved the way for the transformation. The handcomber had arrived at a point of existence at which any alteration in his condition could hardly render his lot more miserable. While other artisans had been able in the main to retain their relative status amongst textile operatives, the handcomber had sunk lower and lower in the scale, until he had become a byword for misery and want. By 1848 he had lost all his old independence of

spirit and power of self-assertion ; he could fight against fate no longer, but accepted humbly, though with much purposeless lamentation, the hard and hopeless position into which untoward circumstances had forced him. Twenty years earlier he would resolutely have resented the encroachments which the masters were compelled to make upon his former rights, pay, and privileges, but in the face of the machine which Mr. Lister was fast pressing upon the attention of spinners he had not the courage to do battle on the old lines. It was a slow submission to the inevitable. The aspect of industrial matters was undergoing a radical change. The fine wool trade was just starting, and unless Bradford was able to keep pace with the increased demands in this direction, a large portion of our manufactures would gravitate to France, which was already supplying us with large quantities of yarns. But even in this there was little hope held out for the handcomber, for the machines which Mr. Lister had sold to Messrs. Wood and Walker, to Messrs. Rand, and others, could in many respects excel the work of the handcomber.

For handcombing the sorting had to be more severe than for the machines ; "shorts" to the extent of some 25 per cent. being kept back for working up into cloth. In this condition of affairs, it was necessary that the combing-machine should be sufficiently developed for

the treatment of fine wools, otherwise the worsted trade of this country would have suffered very seriously. In France they were combing fine wool advantageously by means of the improved Collier machine, and it might be that in the race of invention they would presently altogether out-distance English rivals. No wonder that Mr. Lister, Mr. Donisthorpe, and others, should at this juncture have redoubled their efforts to achieve the more perfect machine. As it was, machine woolcombing was a thoroughly established industry in the worsted district, and the handcomber was rapidly dying out; still there was much to be accomplished, for not one of the great English machines of to-day had then been invented. The Nip, the Square Motion, the Noble had yet to be evolved.

Meanwhile great advances were being made in France. Heilmann had invented his machine for the combing of cotton as early as 1846, and it was not long before it was discovered that it could be adapted with equal effect to the combing of wool. Heilmann's machine, which undoubtedly represented an entirely new principle, was exhibited in Paris in 1849, and although the inventor did not at first seek to introduce it in England, he secured his rights by an English patent, and thus prevented the idea of his machine being taken advantage of by infringers on this side of the Channel. There was much more in Heilmann's machine than was

at first supposed. The invention of his nipper formed an important step in the development of machine-combing, as by it was solved the problem of the perfect and economical combing of the fibre. Even Cartwright's great invention only became of real practical value after the introduction of the nip principle, as worked out in the machines brought forward in England by Mr. Lister. The extraordinary importance of the invention was quickly acknowledged in industrial circles, all more or less occupied with experiments at that time. Many prominent inventors occupied themselves with improving the principle, and Nicholas Schlumberger, at Gwebweiler, constructed additions which made Heilmann's machine suitable for combing short and fine wools. Indeed it was not until Heilmann's wonderful mechanisms had been properly applied by Schlumberger that the invention of the ingenious Alsatian became of real utility.

When Donisthorpe and Lister put their Nip combing machine into the market, the representatives of Heilmann took proceedings against Lister, and it was not until the latter had paid the owner of Heilmann's patent the large sum of £30,000 that he was free to sell the Nip to the trade. Mr. Lister thus made himself master of the situation as far as the introduction of the Nip principle into England was concerned. He could either let the trade have

Heilmann's machine as it stood, or he could sink it in favour of his own Nip machine. He elected to do the latter, and from that time for a few years had great success with his machine and realized considerable gain by it, the royalties paid for its use being unusually large.

In the course of the setting up and working of woolcombing machinery in France by English woolcombers, many difficulties presented themselves; but those difficulties were the means of bringing into existence other new and important developments in this branch of industry. Lister and Holden could not introduce the Nip machine into France without invading the rights of Heilmann's representatives; hence it became necessary to the success of their enterprise that arrangements should either be come to with the proprietors of the Heilmann machine, or that some fresh machine, involving no question of infringement, should be adopted.

It was then that the Square Motion machine came to the rescue. This machine had been patented in England by Mr. Lister. In January, 1849, it had not gone further than Mr. Hattersley's mechanics' shop, and was far from being a perfect machine. There Mr. Jonathan Holden, who had been selected to act as managing mechanic in the works of Lister and Holden at St. Denis, made his first acquaintance with it; and

when he subsequently had to experiment with it in France he found that, except with a very light weight of wool, it was impossible to make it work. Various alterations were made, but the improvements then effected were not sufficient to render the machine thoroughly practicable, so it was laid aside. Then Lister and Holden struggled on a while longer with the old machine that was antecedent to the Nip, and the French enterprise was by no means so bright of prospect as its promoters desired. After a time however the discarded Square Motion was taken up from the scrap heap, and further efforts were made to work the idea out into practicable shape, and this time, thanks to the energetic and intelligent efforts that were put forth, the wished-for end was reached, and the Square Motion woolcombing machine was adopted through the works, and ultimately became the representative machine for France.

Lister and Holden had the Square Motion machine to themselves for a time. But great exertions were made to work the Heilmann machine into favour during this period, the improvements effected by Schlumberger having made it a dangerous rival to the Square Motion ; still Lister and Holden did not lose their hold upon the trade, and in 1858 Mr. Holden removed the Heilmann from the sphere of competition by purchasing it for France, as Mr. Lister had

previously done for England. After that the Heilmann machine gradually fell into disuse in France, and was chiefly confined to the woolcombing establishments of Germany, where it still holds supreme sway, and is for all but the shortest and finest wools a machine of unsurpassed utility, and is constantly being improved.

We now arrive at the period of development represented by the introduction of the Noble combing machine. As we have stated, there was a slight mystery connected with the origin of this invention, but there is little doubt the merit of the practical application of the idea belongs to Mr. Donisthorpe. The Noble machine contained so much of the Heilmann principle however that it could not be adopted in France until the purchase of Heilmann's patent removed all obstacles ; still, the Square Motion was so firmly established in that country that it has not been until the last few years that the Noble has been worked there to any appreciable extent. As regards England, the Noble had a marked effect. It was bought by Mr. Lister, and the trade took it up so readily that before very long it had almost entirely superseded the Nip for fine wools.

The three machines which rule the woolcombing trade at the present day are the Square Motion, the Noble, and the Heilmann. The Square Motion is in general use in France, and is, of course, also the

machine in operation at the extensive works of Messrs. Isaac Holden and Sons, at Bradford ; the Noble is, apart from the establishment of the last-named firm, the machine most widely adopted in England ; and the Heilmann possesses the field in Germany.

The effect of the invention of the woolcombing machine upon the industry of the world has been beneficial in the highest degree. Instead of annihilating the workers, it has provided them with easier employment and better remuneration ; and to day, with all the increased power of production which machinery represents, there are more persons employed in the work of woolcombing than there were when the hand-combers were most numerous and most flourishing, even though one machine of the present time performs as much work as from eighty to a hundred hand-combers could have accomplished under the old system. The woolcombing machine gave new life to the worsted manufacture, and cheapened the cost of production sufficiently to enable the masters to cope with depressed markets. A temporary lessening of the number of hands employed at the lowest rate of wages was the immediate result, but a permanent demand for improved labour at an enhanced price was established. Production having been cheapened, the price of the fabric produced continued to be low, and by the lowering of price there was obtained an increase of

demand, which very soon brought up to the old scale the number of people occupied in the business of producing. Thus there was work for the old number of hands, and usually for some new hands too, while there remained the fact that an improved class of work-people was instituted—that so many who might otherwise have remained near the bottom went up a step or two higher in the social scale. Nor were matters made any worse by the fact that females could be employed instead of men in superintending the operations of wool-combing machines. In many cases it meant so much additional income to a workman's household to have these new avenues of employment opened up to his daughters, while he himself might aspire to more skilled labour or positions of higher responsibility and trust.

The woolcombing machine has achieved so much on behalf of the textile industries of Europe and America that the men who have been prominent in its working out deserve the honour and admiration of the world—Cartwright, Heilmann, Donisthorpe, Lister and Holden are the names that stand out most distinctly in the history of this wonderful invention ; but it would be a serious omission, and a forgetfulness of duty, did we not at the same time bestow some recognition upon the important labours of the various ardent workers in this field who have contributed valuable improvements

to the several combing machines now in use, and which have only been perfected by the efforts of many minds. No one of the great combing-machines of to-day can be said to have been entirely created by one man. The leading principle may represent a single creative effort, but the successive developments which have led to the complete practicable machine have only been reached, stage by stage, by constant experiment, and by a grouping as it were from time to time of the hints, deductions, and suggestions of others than the inventors-in-chief in the application of some decided improvement. Cartwright was a great inventor, but the wool-combing machine as he left it would be of no use whatever now. Heilmann's machine was one of the most remarkable inventive achievements of the nineteenth century, but it wanted Schlumberger's improvements to make it a success. Lister and Donisthorpe's first machines showed great inventive ability, and in their day worked well, but the Nip drove them out of the field, and now the Nip itself is in a considerable measure shouldered into obscurity by the Noble. As for the Square Motion, as originally patented it was almost incapable of combing wool; it took years of effort and the cooperation of many practical minds to bring it to perfection. In the same way the Noble machine could not hold its own with rival inventions, had it not been for the later improvements introduced by men who had

nothing to do with the original machine. The mere enumeration of the names of these men would be a task of some difficulty, as will be apparent from a glance over the list of inventions given in the Appendix. Indeed many improvements which were of importance at the time of their introduction, have been lost sight of in the overshadowing value of more recent discoveries. Then, again, numerous inventions were bought up by the proprietors of the leading machines in order to restrain competition, and in a variety of ways steps were taken to keep the trade in the hands of the few.

Amongst those who deserve mention as improvers of the original Cartwright machine, we may refer to Henry Ross, whose inventions of 1837 and 1841 presented features of undoubted merit; to C. A. Preller, in respect of his patent of 1842, in which he first introduced the principle of transferring by hand a half-cleaned tuft from one comb to another; to Samuel Crabtree, for an improvement upon Preller's idea; to Ramsbotham and Brown, for their improvements adapted to Ross's machine; and to the valuable contributions of Henry Rawson, J. Warburton, C. Cowper, and T. Whitehead, respectively. We have already drawn attention to the alterations on Heilmann's machine effected by Lister, Donisthorpe, Crofts, and others, but, in addition to these, various

minor inventions, forming an aggregate advance of marked importance, stand to the credit of names less widely known in this connection—W. Busfield, Messrs. Illingworth, G. Little, T. Whitehead, Messrs. Jefferson, Messrs. Smith, and others. In reference to the Square Motion machine, there has been little improvement effected by any one outside the firm of Messrs. Isaac Holden and Sons. The name of Mr. Lister appears alone on the original patent, but in all other patents since taken out representing developments of the square motion principle Mr. Isaac Holden has been chiefly concerned. The fact that Messrs. Isaac Holden and Sons have kept the machine mainly in their own hands will explain to a great extent why the Square Motion did not attract the amount of general inventive effort that the other machines did. With the Noble machine it was very different. Its original imperfections called forth a host of remedial suggestions, after the first two or three years, and the position which this machine holds at the present time is largely due to the valuable improvements introduced by others than the first inventors. An extraordinary number of patents have been taken out for treating the middle portion of the fibre by intersecting combs. The principal of these were the invention of Thuillier Geller in 1868, of Whitehead in 1869, of Bradley in 1871, and of Lohren

in 1874. In the patents of Geller and Whitehead regard was only taken of the two inside circular combs, which produced the least effective portion of top. Bradley's arrangement referred to the Noble machine with only one interior circular comb, and permitted the employment of intersecting combs both for the interior and exterior combing. It was an improvement of real originality, and was bought for France by Mr. Isaac Holden for 6000*l.* The dabbing brushes of the Noble machine have also occupied a great share of the attention of woolcombing inventors, amongst whom, have figured Mr. Whitehead, Mr. Speight, Mr. Fairbank, Mr. Pollard, Messrs. Priestman and Robertshaw, and others.

Reference should not be omitted to the patents of Messrs. Jefferson, of Bradford, whose improvement of 1866 on Cowper's nipping instrument of 1852 effected the removal of the fringe of short fibres left projecting from the comb by the drawing-off rollers. The same firm introduced improvements in the drawing-off apparatus in 1870; in 1877 they obtained a patent for an overhead feeding apparatus; and in 1884 patented a plan for securing the continuous action of the dabbing brushes on stopping and restarting the machine.

Sometimes an inventor fastens his attention upon one particular part of a machine in which he discovers a defect, and sets himself to remove the fault. Many

fail, and some succeed. Hundreds of examples might be given. Amongst one of the successes is to be counted an improvement in gill fallers effected by Mr. Edward Clarkson, of the Perseverance Works, Bradford, who in 1885 took out a patent for his new idea. Theretofore the pins had been driven through holes formed in a strip or bar of brass, the back of which had afterwards been soldered to the faller, or otherwise similarly secured. Mr. Clarkson's notion was to construct a curved recess in the sides of the faller, which economised the labour of drilling, admitted the pins without seriously taking from the weight of the faller, and also secured to the under edge of the faller, its entire width, instead of reducing the latter to a central web or midfeather as previously. So from month to month the work of invention proceeds, and although perhaps in the majority of patents that are taken out the hopes of the inventors are not realized, the successes are numerous and important enough to mark a gradual and decided progress of mechanical development.

Prominent mention ought to be made of the woolcombing improvements of Messrs. Little and Eastwood, patented in 1871, which were supposed to render the machines of the Cartwright type capable of combing short and dirty wools. Lohren alludes to them as a complicated combination of the working parts

of Lister's and Rawson's machines, and as remarkable for employing Heilmann's nipper in the shape of a drum—an idea already brought forward by Lister and Tongue in 1856, but developed to a certain degree of perfection by the American inventor Whipple, and protected by him in a number of patents. Little and Eastwood employed six jaws with an intermittent motion. This machine, which was made by the eminent firm of Platt Brothers, was shown at the Vienna Exhibition of 1873, and was adopted in several combing establishments. It did not, however, with all its ingenuity of construction and originality, command the permanent patronage that was accorded to the better known machines, and is not now largely in use either in this country or abroad.

Amongst other discoveries of important principles of mechanism in connection with woolcombing the name of Emil Hubner should be specially referred to. It has been pointed out how Cartwright's system has arrived at its present state of perfection in three different epochs ; firstly, through the adoption by Lister of the straight nipper ; secondly, by Little and Eastwood's insertion of the nipper drum ; and lastly, by the application of Holden's circular intersecting comb. It has further been proved that Noble's combing machine was perfected only by the application of the radial segment combs, and that the improvement is to be traced back

to Heilmann's elementary mechanisms. Hubner's invention was also a modified form of Heilmann's fundamental ideas, and the beautiful discovery made by Hubner is only the necessary consequence of his endeavours to apply Heilmann's nip in a circular form, Hubner pursued this idea at a time when Heilmann's invention had not yet stood the full test of practical application. He discovered the fact that a fibre held fast by the jaws of the nipper always retains its position to the jaw which is covered with leather when the latter is displaced upon the second polished jaw. Hubner expressed this interesting discovery in the following rule :—" If a fibre is held fast between the two jaws of a nipper, one of which is rough and the other polished, and one jaw is then moved upon the other, the fibre, in consequence of the greater frictional resistance, will participate in the movement of the rough surface, and slide over the polished one, which latter will produce no other effect but that of pressure, thereby preventing the fibre leaving the closed nipper." In the application of this idea Hubner and those with whom he became associated achieved a marked success.

The minds of inventors are still actively employed in improving the numerous mechanical details of the various orders of machines, and in every operation that affects the fleecy fibre, from the period of its growth on the back of the sheep to the last touch of

fabrication that it undergoes, efforts are always being made to better its treatment. Now it is in one process, now in another, that progress is made, but the work of evolution never stops. Even on such a matter as the washing of sheep the minds of wool-growers and wool-dealers are much exercised, and a movement is on foot—ably, persistently and vigorously piloted by Mr. John Scriven—for inducing farmers to send their wool to the market unwashed, instead of having the sheep washed before they are clipped, Mr. Scriven's contention being that it would be to the advantage of the trade for English wool-growers to imitate the Colonies in this. The Bradford Chamber of Commerce and the Chamber of Agriculture have had the matter under their consideration, and there has been an abundance of discussion on the subject, the Wool Supply Committee of the Bradford Chamber of Commerce having reported against Mr. Scriven's proposal. On the other hand, such an instructed authority as Mr. Isaac Holden expresses the opinion that "washing wool on the sheep's back, as well as scouring it, as it is called, after being clipped, before sending it to the market is absurd, injurious to the wool, and wasteful." Thus wool in all its aspects constantly engages public attention, and from whatever standpoint we regard the useful fibre, we find it worthy of the closest study.

But to attempt to describe in detail the manifold improvements which have made the leading woolcombing machines the almost perfect instruments of to-day would require another volume. Suffice it that we have shown that although Lister, Donisthorpe, Heilmann, Holden, and Noble are the names which are more particularly associated with the several machines which have now the command of the woolcombing trade, still much of the general merit of the several inventions should be credited to the busy workers whose practical skill has had so much to do with their full development. The history of the woolcombing machine is a record of gradual progress built up of failures as well as successes. The former have pointed the way to the latter. Further, it has not been the inventors alone who have won all the honours ; indeed, as has been sufficiently indicated in the course of our narrative, they have in some instances received but a small proportion of the rewards of their genius. The practical man of business, who has had the insight to discover the merit of an invention, and the capital, energy, and skill necessary to its proper application, has profited perhaps most largely by the mechanical triumphs which have been achieved in woolcombing ; and but for him, it is only fair to add, the work of development would have been greatly retarded. In such men as Mr. Lister and Mr. Holden there appears

to have been a happy combination of business tact and inventive ability; to them, therefore, there has rightly fallen very substantial rewards. Cartwright was peculiarly unfortunate in his attempts to utilize his invention, and, although he bequeathed to the trade a machine which was the foundation of most of those which followed, his efforts brought him far more loss than gain. Donisthorpe had a happier experience, inasmuch as in his dealings with Mr. Lister he succeeded in obtaining several handsome sums for his patent rights, but large as these were in the aggregate, they could hardly be considered, in the light of subsequent events, and in comparison with the profits realized by others, as adequately representing the value of his contributions to the accomplishment of machine woolcombing. Heilmann fared even worse than Donisthorpe in regard to monetary results, but before he died he had the satisfaction of knowing that his invention would at least yield fortune to his representatives if not to himself. As regards other inventors—the men who have introduced improvements in those details of mechanism which have done so much to give perfect working—they have, for the most part, received their due recognition; and so it will probably be in the future; there still may be great creative efforts looked for in connection with woolcombing, although the machine as it exists practically does

all that it was needed to do, and long since passed the stage of building up. There will always be room for fresh contrivances in details of working—sufficient to employ the inventive faculties of those engaged in the operations of woolcombing—but the field has been so thoroughly worked, and such a degree of perfection has been attained, that there is no longer the incentive that there formerly was for an inventor to devote his life and genius to the task of woolcombing development. The matter is now in the hands of the trade, and to those who embark their whole energies in woolcombing enterprises there will ever be found room for the employment of new ideas, the remedying of defects, and the adoption of exacter methods in small things; but the existing machines, representing as they do the result of a century of extraordinary inventive achievement and an equal amount of concentrated business energy, fulfil the requirements of the trade so completely that inventors long since ceased to think of the possibility or advisability of evolving another entirely new machine. Still, with the achievements of the past in mind, which represent the surmounting of difficulties that at one time seemed almost beyond man's ingenuity to remove, it would be idle to say that the record of invention is finished as far as the woolcombing machine is concerned.

It would be no easy task to attempt to summarize the effect which the woolcombing machine has had upon the well-being of the world. The extent of its influence can hardly be realized. What it has done for the worsted trade we have made some endeavour to set forth ; to trace its action in all its multifarious consequences would be to touch upon almost every phase of human existence. Great as were the uses to which wool could be put when the operation of combing was performed by hand, its utility has been increased a thousand fold since machinery was brought into play to lessen the cost, perfect the texture, and swell the variety of wool products. Under the manual system, in the ancient staple trade of England, from the shearing of the wool to the packing up of the finished cloth, the very simplest appliances were employed, and nearly every stage was confided to the personal charge of individual and isolated men. The shearer clipped the sheep's wool, which was delivered over to the washer to be cleaned and dried ; the solitary comber toiled beside his stove and pulled the fibre out into smoothness ; the spinner in her cottage twisted her distaff, and turned and reeled the threads ; and then the weaver took up the threads of warp and woof and wrought them into fabrics on his lonely loom. But little by little invention simplified and improved the various processes, and labour which had previously

been scattered was drawn together in combined enterprises, and the whole aspect of the trade in wool underwent a stupendous change—a change in which the woolcombing machine has been a ruling force.

An invention which has tended in such a remarkable degree to increase the world's consumption of wool has a strong claim upon our admiration, and the men who have succeeded in building up the machine from its first rude beginning to its final consummation are surely to be classed with the world's chief benefactors. Wool is the easiest to produce of all fibres used by man for the purposes of clothing. Wherever a blade of grass will grow, there can wool also be grown; and wherever sheep are kept the land which affords them sustenance improves in quality and productiveness. In the maturing of most other fibrous materials, much care, skill, and outlay are required, but with wool-bearing animals all that is needed is the open fields and a few simple shepherds. The ground has not to be cultivated for the sheep, and the shepherd requires no special training or education to fit him for his occupation. Touchstone, in *As You Like It*, on being asked how he likes "this shepherd's life," replies, "Truly, shepherd, in respect of itself it is a good life, but in respect that it is a shepherd's life, it is naught. In respect that it is private, I like it very well; but in respect that it is solitary, it is a very vile life. Now in

respect that it is in the fields, it pleaseth me well ; but in respect that it is not at the court, it is tedious." And as far as the shepherd's calling itself is concerned, it is much the same now as it was in the romantic days when Rosalind and Celia invaded the picturesqueness of pastoral life in the Forest of Arden. As regards all else, the change has been extraordinary ; and where, before the woolcombing machine came into active existence, there was one flock of sheep, there are now a thousand. But for this development in the production of wool fabrics, the Australian Colonies could not have had a tithe of the prosperity which the growth of its flocks has given to them ; and the vast plains of the La Plata would not now be given over to the pasturage of millions of sheep and creating new wealth for the Argentine Republic. The world's wool-growing resources are inexhaustible, and the yield will go on increasing from year to year until a degree of cheapness is arrived at that will even be as marked a contrast to the prices of to-day as the latter are to the prices of half a century ago. Silk, cotton, flax, and jute, can only be produced in certain countries, and under certain conditions, and at a considerable expense of cultivation ; wool, on the other hand, is indigenous almost to every country of the universe, and can be grown with a much smaller expenditure of labour than is required for the production of other fibrous sub-

stances. It is true, it is more costly than most of its rival fibres in the processes it has to undergo in course of manufacture, but the perfected woolcombing machine has reduced this expense to a minimum, and succeeded in placing the fabrication of goods from combed wools in the very front rank of the world's industries.

APPENDIX.

APPENDIX.

A LIST OF THE PRINCIPAL WOOLCOMBING INVENTIONS OF DIFFERENT CLASSES, USED IN WOOLCOMBING IN ENGLAND, FROM CARTWRIGHT'S TIME TO THE PRESENT.

2524. July 2, 1801. Rev. EDMUND CARTWRIGHT, Act of Parliament, 41 George III., embodying Letters Patent 1747, of April 27th, 1790; 1787, of December 11th, 1790; and 1876, of May 15th, 1790.

A principal comb moving at right angles to the direction of its own teeth; a clearing comb with similar movement; filling and drawing-off rollers. Clearing comb moves in a plane at right angles to the plane of principal comb. All the wool-combing operations go on at the same time, each at the same time, and each at its proper part of the circle so long as the machine is in motion and wool is supplied.

2172. March 11, 1793. WRIGHT & HAWKSLEY.

Combing cylinder, teeth either horizontal or perpendicular; fly with brushes and rollers to lay wool close to teeth of cylinder; vertical circle.

2172. March 11, 1793. SELLARS, WILLIAM.

Hand combs: comb teeth horizontal, pointing to centre of frame; working with comb wheel.

2185. July 4, 1797. HAWKSLEY.

Improvements on the last-named machine.

1793. TOPLIS, WILLIAM.

Combs with curved teeth fixed on arms, and combers which when in action turned in the direction of the combs.

1795. PASSMAN, JOHN.

Method of opening staple and bringing it into proper state for lashing on comb.

1795. AMATT, ANTHONY.

An invention providing a separate machine for each of the three principal motions of filling, combing, and drawing off.

2861. 1805. NOBLE, JAMES.

Upright combs carried by travelling carriage reciprocating to comb the wool. Fluted drawing rollers drawing wool from comb parallel with the comb head.

1811. GILPIN, GEORGE.

Woolcombing machine, with mounted framework holding four rings of iron, with six arms, each mounted upon iron spindles placed parallel to each other. Wooden bars were fixed parallel to each spindle, forming a frame to these bars, and to these were attached the combs.

3829. August 4, 1814. COLLIER, JAMES.

Superseding hand combs and comb pots; supply of steam to roller; apron travels to supply wool to fluted rolls, whence it passes to comb roller; draw off and delivery.

5243. March 4, 1826. ANDERTON, G.

Wool passes from feed apron to and between two pair of rollers and is then seized by revolving circle working with fixed and other revolving combs.

5560. November 28, 1827. PLATT, JOHN.

(This machine was really the invention of Mr. John Collier of Paris, and was probably communicated by him to the patentee.)

Combing effected by the movements relatively of two circular combs edged with steel teeth. Both comb circles work angularly from a plane. The teeth are at right angles to the plane of the wheel. The teeth of the one circular comb sweep with a steady obliquity over the teeth of the other comb. Combing commences on the tips of the tresses where the wheels by the obliquity of their shafts are at the greatest distance apart, but as the planes approach parallelism the teeth move deeply enter the wool and effect the combing.

6559. February 20, 1834. NOBLE, JAMES.

Long arm carries at one end comb teeth which work in an elliptical curve consequent upon a combination of movements given by a cam wheel under the middle, and a crank connected to the end opposite the comb of this long arm. The long arm teeth strike into and comb the wool fed by hand into comb teeth points upwards fixed to a carriage moving backwards and forwards worked by a spur wheel and a worm driven by the machine.

Instead of introducing the wool to be combed into the lower needles by hand it is sometimes fed in by an endless feeding cloth actuated by screw gearing. Another plan of working the lower needles is by substituting rows of needles set obliquely on the periphery of a drum rotating in a contrary direction to the upper teeth as they descend, the drum working nearer and nearer to the combing point by screw gearing.

6806. April 3, 1835. DONISTHORPE, GEO. E. and RAWSON, HENRY.

Straight downwardly pointing rows of teeth rise to allow upwardly pointing straight rows of sliding teeth to come under the charge of wool, and then the former rows descend bringing their charge of wool into the lower teeth, and the separation of the two rows by the recession of the sliding teeth away from the stationary teeth combs the wool.

6994. February 3, 1836. BARING, JOHN.

Comb circle or endless band of combs travelling horizontally; wool lashed on by cylinder of teeth travelling at right angles to the line of travel of the circle or band; wool withdrawn off according to length by rollers at different distances; and shortest wool cleared off by a comb cylinder working up the teeth of the circle.

7047. March 29, 1836. NOBLE, JAMES.

The feeding comb is gradually made to advance on a moveable table towards the rotatory comb carrier until the wool on it is used up, then it returns for fresh wool.

7362. May 6, 1837. ROSS, HENRY.

1st. Filling combs by means of spiked rollers fed from bobbins.
2nd. Wool, in teeth of a wheel in double series outwardly pointing and caused to rotate, is subjected to combing action of teeth set to point at right angles to the circle teeth and so as to meet and enter the travelling fibre in direction of its length.

3rd. Heating comb teeth by means of flame of gas. Rollers draw off first long and then short wool.

7377. May 23, 1837. SMITH, SAMUEL and WM.

Heating comb circle interiorly by introducing steam into hollow spokes and boxes.

Laying wool into combs with aid of streams of air.

7452. October 26, 1837. BERRY, MILES, from some one residing abroad.

Endless horizontal belt of teeth carried on pulleys.

9121. October 15, 1841. ROSS, HENRY.

Transposing order of lengths of teeth from longest in front diminishing to third or fourth, or substituting intermediate arrangements: Grooved teeth: Filling and heating combs and heating comb heads.

9142. November 9, 1841. ROSS, JESSE.

Filling, combing, and drawing.

9404. 1842. DONISTHORPE, GEORGE EDMUND.

Working comb teeth set coarser and finer at opposite ends : combined rotatory combs (having movement towards their axes in act of combing) and curved or circular combs.

9408. 1842. PRELLER, C. A.

Combining combs and card transfer by hand combs. Endless linked plates of comb teeth.

9453. 1842. HENDRY, T.

Feeding rolls ; Crank motion to combs.

9780. July 15, 1843. DONISTHORPE, G. E.

Returning wool from working combs to carrying combs : sliding plates and points for same : Heaters to combs.

9966. November 25, 1843. DONISTHORPE, G. E.

Holding wool in comb during intervals of feed : Air blast to raise wool fringe to facilitate drawing rotatory combs regulated by eccentrics passed by straight comb whose wool they comb out.

10,336. 1844. LISTER, S. C.

Saddle comb recedes as revolving comb passes through the wool, to relieve strain.

10,433. 1844. PERRY, JOHN.

Endless chains of combs with teeth to enter wool parallel to teeth of supply combs.

10,872. 1845. WHITEHEAD, J.

Horizontal travelling combs above frame of horizontal reciprocating and rising and falling combs.

11,004. December 12, 1845. LISTER, S. C.

Working dry fine wools by porcupines with fine teeth in connection with comb.

11,013. December 22, 1845. NEWTON, A. V.

This was presumably the invention of and a communication from M. Seydoux.

System of combing by two machines with combs unheated and not intersecting.

11,103. 1846. HEILMANN, JOSUÉ.

Tufts of fibre broken from sliver comb at each end, and long and short wool selected into separate slivers ready for subsequent treatment.

11,461. 1846. RAMSBOTHAM, R. H.

Lashing wool into combs and drawing off without working by working combs after lashing into receiving combs: Circular comb with teeth rising up: Screw gill working combs coöperating with circular comb: Taking to slivers from circular comb: Heating comb circle teeth.

11,469. 1846. LISTER, S. C.

Screw gill comb teeth pointing upward working with circle comb.

(Fourteen other heads of invention.)

11,508. December 21, 1846. PERRY, J. and NOBLE, J.

Cylindrical circular comb rotating working in conjunction with circular working comb having teeth set on its periphery.

11,896. October 7, 1847. LISTER, S. C.

Operating combs to work with circle combs in various arrangements.

12,287. October 5, 1848. BAILEY, J. S.

Combing by combs attached to arms moving in opposite directions at different velocities.

12,289. October 19, 1848. LISTER, S. C.

Motion similar to that of a screw gill, without a screw, by use of cams revolving on a shaft.

12,603. May, 1849. DONISTHORPE, G. E. and WHITE-HEAD, J.

Drawing out tufts of wool finger-and-thumb wise from body of wool held in holders.

12,712. July 18, 1849. LISTER, S. C. and DONISTHORPE, G. E.

Keeping plate applied between rows of teeth in circle or holding comb.

13,009. March 20, 1850. LISTER, S. C. and DONISTHORPE, G. E.

Improvements on 12,603⁴⁹ and on Heilmann of 1846. Portions relating to each head were disclaimed subsequently.

13,013. March 23, 1850. RAMSBOTHAM, H. R. and BROWN, W.

Increasing draught of drawing off rollers in using porcupine rollers.

13,532. February 24, 1851. HEILMANN.

Heating Heilmann machine and making front teeth of comb as fine as the back teeth.

13,553. March 13, 1851. ROSS, JESSE.

Improvements on his prior Patents :

7362 of May 6, 1837 ; 9121 of October 15, 1841 ; and 9142 of November 9, 1841.

13,794. November 3, 1851. GREENWOOD, T. & WARBURTON, J.

Filling head oscillating : Retaining comb to hold sliver during feeding to traversing combs : Double travelling combs with comb teeth projecting out at right angles to line of travel in opposite directions.

13,822. November 20, 1851. BAILEY, J. S.

Improvements on his prior Patent :
12287 of October 5, 1848, and other modifications.

13,950. February 2, 1852. LISTER, S. C. and AMBLER, J.

Combined nipping and combing action in effecting detached portions of wool for transfer to another comb : Improvements on Preller 1842 and Noble 1836.

13,957. February 9, 1852. FEATHER, J. and DRIVER, J.

Acceleration screws of varying pitch to increase speed.

13,977. February 23, 1852. COWPER, CHAS.

Friction holding or retarding surfaces to hold sliver while combing.

14,003. March 8, 1852. NEWTON, A. V.

Feeding and drawing-off mechanism.
Modifications of arrangements.

14,045. March 27, 1852. BOURCART, J. J.

Improvements on Heilmann's machine enumerated.

14,050. March 29, 1852. WHITEHEAD, J.

Combining, preparing, and combing ; reciprocating the screw gill drawing heads and feeding apparatus.

14,188. June 24, 1852. BAZLEY, T.

Detaching tufts through comb teeth and conveying same to circle teeth.

14,292. September 16, 1852. PRELLER, C., EASTWOOD, J., and GAMBLE, S.

Successfully combing, straightening, and depositing in combs small tufts of wool.

151. October 2, 1852. SHARP, D. W.

Intermittent feed, etc.

558. October 29, 1852. RAMSBOTHAM, H. R. and BROWN, W.

Doffing arrangements.

683. November 9, 1852. ZIEGLER, J. J.

Modifications of Heilmann's 1846 patent.

710. November 11, 1852. NOBLE, JAMES.

Combs on rotary axes move to and from endless band of combs.

927. December 1, 1852. MILLIGAN, R.

Facilitating drawing off in continuously moving series combs.

1180. December 28, 1852. BUSFIELD, W.

Curving course of gill teeth, nipping surface and transferring comb in nip machines of Lister and Donisthorpe and Lister.

216. January 28, 1853. DONISTHORPE, G. E. and CROFTS, JOHN.

Porter comb with teeth downwards. Rotary transfer comb, etc.

799. April 4, 1853. ROSS, J. and ROSS, T. R. H.

Arrangements of feed keeping plates, brushes, and delivery apparatus.

835. April 7, 1853. MOWBRAY, F. W.
Brushes or teeth to act in conjunction with nip. Forming nip with two or more ribs and grooves.
890. April 13, 1853. NOBLE, J.
Feeding by roller of inclined teeth detached portions taken by rotating combs. Comb partially rotates at moment of feed. Fibres nipped during detaching by arm coming in contact with fixed cam.
894. April 13, 1853. NOBLE, JAMES.
Two rotating rings one within the other, their peripheries nearly touching at one point at which the fibre is laid across their adjacent rings of teeth, and is combed by their teeth travelling at the same rate of rotation separating.
981. April 23, 1853. HOULDSWORTH, HY.
Producing the various motions from one cam, and other modifications of the Heilmann machine.
983. April 23, 1853. JOHNSON, W.
Duplex chain comb and right and left hand combs.
1029. April 28, 1853. HETHERINGTON, J.
Modifications of Heilmann machine.
1043. April 29, 1853. VIGOUREUX, J. S.
Combing by two comb wheels on parallel shafts, the teeth of one wheel set in directions opposite to those of the other and caused to approach and separate.
1137. May 9, 1853. JOHNSON, J. H. (a communication.)
Pairs of combs move toward circular comb dip into wool and retire in order to comb; blast of air delivers wool to the draw off.

1157. 1853. LISTER, S. C.

Two endless chains of combs moving parallel, with working comb between; wool taken from one comb worked by working comb and placed on the other comb. Each travelling comb has its feed, worker, draw off and milking rollers.

1220. May 18, 1853. COWPER, C.

Improvements on 13,977 of 1852.

1282. May 25, 1853. DEVERTE, L. A.

The wool is charged in "Chargesse" machine and transferred to "Peigneuse" machine, one set of teeth pointing upwards and the other set downwards.

1412. June 9, 1853. SMITH, J.

Two circles of combs; teeth of each facing in opposite directions towards one another, each set inclining inwardly, each circle intersecting slightly the other.

1547. June 25, 1853. ILLINGWORTH, D. A. and HY.

Additional motion to cleanse projecting end of tuft before nipping.

1987. August 27, 1853. HARGREAVES, WM.

Wool feed and worked between crank comb and straight travelling comb.

2244. October 1, 1853. DAVIES, E.

Carrier combs taking in straight line and delivering in curved form on circle.

2249. October 1, 1853. AMBLER, J.

Transfer arrangements.

2370. October 14, 1853. NEWTON, W. E.

Intermittent reciprocating feed to nip, etc.

2394. October 17, 1853. LISTER, S. C.

Filling heads for short fibres.

2432. October 21, 1853. MARSHALL, J. G. and FAIRBAIRN, P.

Single framing to Heilmann machine : Feed delivery by pumps.
(Provisional protection.)

2594. November 8, 1853. JOHNSON, J. H.

A communication from Alp, Paris. Rectangular motion imparted to working comb to effect combing in comb circle wool.

2737. November 24, 1853. LISTER, S. C.

Holding instrument to prevent robbing.

2810. December 2, 1853. LISTER, S. C.

Combing directly from card doffer : transferring by an oscillating comb.

2937. December 17, 1853. BAILEY, J. S.

General modifications of his previously patented machinery.

2037. December 31, 1853. HOLBREY, J.

Endless bands of combs.

60. January 10, 1854. DREVELLE (MOREL).

Nacteur comb introduced.

165. 1854. SEEBOHM, HY.

Conical combs revolving on axes inclined to each other, points coming together at one place.

182. January 24, 1854. LISTER, S. C.

Feeding apparatus to and fro motion. Improvements on
13 950⁵².

627. 1854. BINNS, M. and POLLARD, J.
Auxiliary comb : teeth of angular section.
634. March 16, 1854. MARSHALL, J. G. and FAIRBAIRN, P.
Intermittent rotary motion to draw off : Condensing prior to discharge.
733. March 30, 1854. PASSAVANT, P. J. and CURE, J.
Improvements on Preller's machine, patented 1842.
823. April 7, 1854. WHITEHEAD, T.
Convex nippers, fallers, and carrying combs in conjunction with circle combs.
854. 1854. FOTHERGILL, B. and WEILD, W.
Double nip, feed, and other parts.
896. April 18, 1854. DENTON, W.
Fixed serrated blade for retaining the sliver to prevent spreading at the draw off.
910. April 20, 1854. BROWN, H.
Holding plate to hold fibres in comb against combing drag.
1371. June 22, 1854. COWPER, C.
(A communication from a foreigner residing abroad.) Various modifications of machinery the subject of Cowper's Patents of 1852 and 1853.
1551. July 14, 1854. DERHAM, J.
Screw gill feed mechanism reciprocating drawing-off apparatus.
1855. August 23, 1854. FAIRBAIRN, P. and GREENWOOD, T.
Applying to one and same comb cylinder a taking comb and rear working combs.

1969. September 8, 1854. RAMSBOTHAM, H. R. and BROWN, W.

High back teeth: Improvements adapted to Ross's machine, patented 1837. Additional catch comb.

2017. September 18, 1854. CRABTREE, SAML.

Actuating taking combs.

2125. 1854. TOWNEND, W.

Curved push plate actuated by spring to push wool towards circular comb.

2221. October 17, 1854. ILLINGWORTH, A. and H.

Actuating nipping apparatus.

2363. November 8, 1854. STEAD, W., SPENCE, M., and WOOD, S.

Modifications in construction of Preller's combing machine.

2446. November 18, 1854. RAMSBOTHAM, H. R. and BROWN, W.

Transverse motion in addition to ordinary feed motion to the screw gill feed combs.

2491. November 25, 1854. ROBERTS, R.

Lashing motion.

29. January 5, 1855. BULMER, W. K. and BAILEY, W.

Improved nip motion. Progressively increased speed to gill comb bars.

429. February 27, 1855. FOTHERGILL, B. and WEILD, W.

Improvement on 854, 1854.

-
538. March 9, 1855. LISTER, S. C.
Cleaning before detaching part of sliver.
641. March 23, 1855. JOHNSON, J. H. (BONSUS, F. I.)
Drawing mechanism.
788. April 10, 1855. JOHNSON, J. H. (BROSSER, V.)
Combing by screw gill, nip, and drawing.
858. April 18, 1855. LAWSON, J. and DEAR, S.
Screw gills working with accelerated motions given them.
1088. May 14, 1855. EASTWOOD, T. C. and WHITLEY, T.
2926. May 26, 1855. MAY, C. and COWPER, E. A.
General modifications of arrangements of details.
1785. August 7, 1855. LISTER, S. C.
Actuating "nip" mechanism.
1910. August 23, 1855. DENTON, WM.
Drawing-off rollers ; arrangements modified.
2519. November 8, 1855. WHIPPLE, C.
Operating "nip" mechanism.
2927. December 27, 1855. COWPER, E. A.
Wheel type comb.
53. January 7, 1856. LISTER, S. C. and TONGUE, W.
Quickening "nip" action.

1058. May 5, 1856. HOLDEN, ISAAC.

Downward extensions to gill bars. Cam lever pushes keeping plate to travelling circle, &c.

378. February 14, 1856. RAMSBOTHAM, H. R. and BROWN, W.

Transfer combs : Gill combs at right angles to taking combs.

469. February 26, 1856. WARBURTON, J.

Two circular comb circles pass fibre to third comb.

2582. March 3, 1856. WESTLEY, W. K.

Chain comb arrangement. Bell crank action.

1914. August 16, 1856. HARGREAVES, WM.

Guards to Collier machine.

2000. 1856. NEWTON, E. A.

Employment of a number of comb circles, &c.

3037. December 23, 1856. BAILEY, J. S.

Improvements on his patents of 1853, No. 2937, &c. and other modifications of details.

279. January 30, 1857. HOLDEN, ISAAC.

Nacteur comb in entire circle.

280. January 30, 1857. HOLDEN, ISAAC.

Improvement on 1058 of 1856. Direct action lift and push in separate frames : heated race between upper and lower comb tiers.

1080. April 16, 1857. WARBURTON, J.

Improvements applicable to combing machines of the "Colliers" type.

1084. April 16, 1857. WARBURTON, J.
Improvements also applicable to combing machinery of the
"Collier" type.
1624. June 10, 1857. BAILEY, J. S.
Improvements applicable to the type of machine characterized by
the employment of a continuous belt of comb surfaces.
2292. September 7, 1857. RAWSON, HY.
Horizontal drawing rollers within Noble comb circle.
2527. October 2, 1857. ILLINGWORTH, A. and H.
Improvement on Patent of 1854 to same parties.
2566. October 6, 1857. WARBURTON, J.
Improvement in the details of combing machinery of the kind
previously patented by this inventor and known as the "Collier"
machine class.
2612. October 13, 1857. BROOKES, W.
Nip arrangement.
3177. December 28, 1857. HOLDEN, ISAAC.
Successive preparation with increase of draught in two gill series
broad gill bars.
3159. December 24, 1857. CROFT, G. and STEEL, S. D.
Segment combs on arms.
597. March 22, 1858. HOLDEN, ISAAC, and HUBNER, E.
Continuous operating nip arrangements.
1075. May 12, 1858. BAILEY, J. S. and W. H.
Controlling motion of taking combs.

-
1193. May 27, 1858. COWPER, C.
Nip motion, feed, and detaching apparatus.
1336. June 12, 1858. CLARK, W. (BOURCART, J. J.)
Operating the "nip" devices.
1729. July 31, 1858. BAILEY, J. S.
Dispensing with transfer combs, etc.
1906. August 21, 1858. DE JONGH, C.
Improvements on his patents of 1856.
2599. November 18, 1858. COWPER, C. (ZIEGLER, M.)
Improvement on De Jongh's of 1856 and 1858.
33. January 4, 1859. JOYCE, J. B.
Drawing arrangements.
52. January 7, 1859. HOLDEN, I. and A.
Nacteur comb divided into circle of segments.
249. January 27, 1859. RAWSON, HY.
The Rawson type.
346. 1859. SMITH, I.
Circular carrying comb and endless web, etc.
996. April 20, 1859. RAWSON, HY.
Continuous web carrying comb.
1050. 1859. JOHNSON, J. H. (WHIPPLE, C.)
Keeping fibre during combing in contact with heated surface.

-
2383. October 18, 1859. NEWTON, W. E.
Taper continuous chain carrying (De Jongh, C.) improvements
on 1211 of 1856 : 1765 of 1858.
2673. November 25, 1859. DONISTHORPE, G. E.
Combining comb teeth with nip.
2832. December 13, 1859. LISTER, S. C. and WARBUR-
TON, J.
Improvement on Mr. Lister's patent of 1851, Cowper's of 1852
and Warburton's of 1857.
2980. December 29, 1859. FAIRBAIRN, SIR P. and NEW-
TON, R.
Pair of endless bands of combs.
810. March 29, 1860. HOLDEN, ISAAC.
Keeping plate worked from square motion slides : spring pull
back : push of comb bars commenced before their attainment
of full height.
1083. April 28, 1860. RAWSON, H.
Improvements on 996 of 1059.
2968. December 3, 1860. WHITEHEAD, T.
Two travelling combs working in different planes ; fibre carried
from one to the other.
100. January 14, 1861. BALDWIN, J. WOOD, C. and
CROSSLEY, J.
Alternating movements to drawings rollers and gill combs.
395. February 16, 1861. NUSSEY, N.
Oscillating nipping jaw devices.

-
2317. September 17, 1861. EASTWOOD, J. and JOYCE, J. B.
Improvement on Whipple machine of 1859.
2358. September 20, 1861. BOUSFIELD, G. T. (WHIPPLE,
C. and STAFFORD, R.)
General arrangement of Whipple machine.
2367. September 21, 1861. TONGUE, W.
Improvements on Lister and Warburton's 2832 of 1859.
2369. September 21, 1861. TONGUE, WM.
Partly for improvements on Noble machine arrangements.
2650. October 23, 1861. MOREL, A.
Various arrangements.
596. March 5, 1862. TONGUE, W.
Improvements on Rawson 249 of 1859.
752. March 18, 1862. TONGUE, W.
Improvements on Rawson's 249 of 1859.
752. March 18, 1862. TONGUE, W.
Improvements on Lister's 1851 Patent and various other patents.
1055. April 12, 1862. NUSSEY, N.
Oscillating feeding head arrangements.
1070. April 14, 1862. DARGUE, J.
Improvements on 13,532 of 1851.
1345. May 6, 1862. MOREL, A.
Annular arrangement and multiplication of "working" parts.

1850. June 24, 1862. HARGREAVES, W. and LEATHIER, G. H.

Revolving nipper within revolving dial comb.

1890. June 27, 1862. HOLDEN, ISAAC.

Improvements on 1058 of 1856, 280 of 1857. Inclined ended nacteur comb segment bars: outside direct acting screw driving teeth on main circle. Improvements on 52 of 1859.

2104. July 24, 1862. RAWSON, H. and STAPLES, F.

Improvements on 1083 of 1860.

2507. 1862. WALKER, J. and F.

Improvements on Preller type of machine with endless belt of combs.

3366. December 17, 1862. TONGUE, W.

Improvements on 249 of 1859 and 596 of 1862.

3392. December 18, 1862. LISTER, S. C.

Various modifications on 1785 of 1855, 2832 of 1859, 1083 of 1860 and otherwise.

3394. December 18, 1862. HOLDEN, ISAAC.

Plate to raise fibre from circle into nacteur combs. Heating comb teeth clearing the combs. Supporting nacteur combs by pillars. Compressing rollers and aprons to gill comb feeders. Guard plate.

758. March 21, 1863. HETHERINGTON, J. M.

Removing Heilmann's feed roller and substituting reciprocating apparatus.

1537. June 19, 1863. MOREL, A.

Nacteur or noil comb applied to 1345 of 1862.

2718. November 3, 1863. BATEMAN, S.
Arrangement for rapidly working fine wools.
3158. December 14, 1863. FOTHERGILL, G.
Improvements on Whipple 1050 of 1859.
111. January 15, 1864. TONGUE, W.
Improvements on 752 of 1862 : 1681 of 1858.
336. February 9, 1864. SMITH, JNO.
Improvements on 346 of 1859.
365. February 12, 1864. DIMOCK, J.
Nipper cylinder construction and details.
731. March 22, 1864. MOREL, A.
Improvements on 2650 of 1861.
757. March 26, 1864. STAPLES, A.
Widening the travelling comb, etc.
2642. October 25, 1864. DONISTHORPE, G. E.
Tubes conveying fibre, to be combed by the separation of the teeth of two endless combs, are made to project over the teeth of the comb.
3065. December 9, 1864. TONGUE, W.
Improvements on 111 of 1864.
3210. December 24, 1864. WHITLEY, T. and JOWETT, J.
Reciprocating feeding heads.
622. March 6, 1865. SMITH, S. & W.
Improvements on Heilmann, 11,103 of 1846, and Lister 13,532 of 1851.

1084. April 18, 1865. WHITEHEAD, T. and NUSSEY, N.
Feeding head.
1550. June 6, 1865. BROOMAN, R. A.
(A communication from Messrs. J. E. & L. Harmel.) Continuous feed and continuous stripping machinery; combs carried on periphery of drum.
1557. June 7, 1865. TONGUE, W.
Heckle sheets combined.
2164. August 23, 1865. LITTLE, G.
Improvements on 2358 of 1861, of 365 of 1864, and other nip machines.
2222. August 29, 1865. BAILEY, J. and W. H.
"Nip" devices additional clearer combs: additional cleaning comb.
2299. September 7, 1865. MOREL, A.
Improvements on 2650 of 1861, 1345 of 1862, 1537 of 1863, and 731 of 1864.
2797. October 31, 1865. DONISTHORPE, G. E.
Improvements on 2642 of 1864.
3123. December 5, 1865. HOLDEN, ISAAC.
Improvements on 52 of 1859, 3177 of 1857. Double series of feeding gill bars, teeth of one pointing in reverse direction to those of the other: supplying oil in passing through feeding gill: intermittent motion to rollers taking from workers of preparing combs of square motion. "Tweedler" has before it belt table on which combined movement compacts the sliver by rolling short ends into slivers. Driving circle by double stud wheel driven by screw on shaft, oiling arrangement for same.

3182. December 9, 1865. **WARBURTON, J.**
Endless travelling belt of combs parallel and straight for greater part of length acting with plate to form nip.
450. February 13, 1866. **WHITLEY, T.**
Applying nip supply of tufts to Noble combs.
586. February 23, 1866. **DONISTHORPE, G. E.**
Improvements on Patent No. 2797 of 1865.
1052. April 13, 1866. **JEFFERSON, J. C. L. M. and GREENWAY, J.**
Improvements on Cowper 13,977 of 1852.
1071. April 16, 1866. **ASH, E. and WHITLEY, T.**
Additional nipping jaws.
1123. **BROOKES, WM. (TAVERNIER, R. T. and J. T. A.)**
Circular dabbing brush arrangements.
1266. May 4, 1866. **MOREL, A.**
Improvements on 60 of 1854.
- 1543 of 1866. **LECOQ, J.**
Endless band combs : reversing motion : modifications in details.
1283. May 5, 1866. **BROOMAN, C. E. (PROUVOST, A.)**
Dabbing brushes.
2128. August 18, 1866. **MORTIMER, S.**
Double train of gear for nip.

2190. August 25, 1866. BOUSFIELD, G. T. (WHIPPLE, C. and JOHNSON, E.

Hand-combing motion with Lister nip machinery feed.

2601. October 9, 1866. MIRFIELD, M. and SCOTT, J.

Feed through porcupine comb and oscillating nip : oscillating transfer comb and various modifications of existing machinery.

2797. October 21, 1866. DONISTHORPE, G. E.

Improvement on patent No. 2642 of 1864.

2746. October 24, 1866. BROOMAN, C. E. (PROUVOST, A.)

Circular rotating plate pressers for fibre into rotating circle combs.

2832. 1866. TAVERNIER, E. and WHITEHEAD, H. W.

Feed boxes keeping plates. Teeth of gill combs to back edge of stock.

3251. December 10, 1866. HOPKINSON, W.

Nipping jaw devices.

293. 1867. SMITH, J. and WILSON.

Combing with "nip" and sheets of travelling pins.

834. March 22, 1867. LITTLE, G.

Arranging nip cams outside for convenience of access. Improvements on 2358 of 1861, Bousfield.

1363. May 8, 1867. DONISTHORPE, G. E.

Separate leads for draw off from large and small combs.

2533. September 7, 1867. SMITH, SARAH, Administratrix of SMITH, J., Deceased.

Combination of card surfaces and endless aprons and series of "nips"

793. March 7, 1868. BROOMAN (THUILLIER-GELLÉE of Amiens).

Additional inclined circular small comb.

935. March 19, 1868. DAVIES, from WHIPPLE, M. D., of Cambridge, Mass.

General arrangement of modification of Whipple machine.

1239. April 15, 1868. FLETCHER, W.S.

Nips and aprons of spiked pins. Improvements on 2353 of 1867.

1672. May 21, 1868. CROFTS, J., DAWSON, R. and KING, J.

Noble's combs made up of limited sections or aprons.

2154. June 7, 1868. LAWSON, J. and FITTON, E. G.

Rotary nips in combination with spiral or screw gills.

3219. October 21, 1868. HOLDEN, ISAAC.

Guard plate acting with nacteur combs.

3276. October 26, 1868. SPEIGHT, T. and FRANCE, W. H.

Barrel porcupine and card belts employed with Noble comb.

10. 1869. HENRY, M., from IMBS, I., of Paris.

Modifications of Imbs' system of combing machine.

530. February 20, 1869. WHITEHEAD, H. W.

Inverted rotary combs.

1099. April 10, 1869. HETHERINGTON.

Improvements on 11,003 of 1846, Heilmann, causing backward movement of the rollers which convey the tufts to exceed half the forward movement.

1394. May 6, 1869. BATTINSON, J. and G. and WHITE-
HEAD, T.

Doffing nip rollers.

1470. May 10, 1869. BATTINSON, J. and G. and WHITE-
HEAD, T.

Teeth of small and large comb interspace and small combs
driven by frictional hold of wool.

2368. August 7, 1869. LAKE, from CONANT, H. of
North Providence, R.I., U.S.A.

Two sets of nipping jaws transferring tufts.

2586. 1869. GREENWOOD and BAPTY.

Turning and transferring nipping apparatus.

2886. 1869. MORRIS and TEALE.

Additional drawing rollers.

3241. November 10, 1869. BATTINSON, J. and G. and
WHITEHEAD, T. and H. W.

Partial clearing of fibres before laying over the teeth of the
combs.

3313. November 17, 1869. CROFTS, J., DAWSON, R. and
KING, J.

Extra set of comb teeth to work with outer circle.

65. January 8, 1870. LITTLE, G.

Two or more cams for actuating the shaft in the Heilmann
machine.

151. January 18, 1870. WHITEHEAD, T.

Improvement on 1394 of 1869 and 1476 of 1869. Lateral
traverse motion to stripper belts.

1077. 1870. LITTLE, G.
Travelling surface to keep fibre detaching roller and rock shaft clear of deposits.
1228. April 29, 1870. JEFFERSON, M.
Traversing leather draw-off aprons by worm and gear operated by tightening roller or draw-off roller.
1531. 1870. EASTWOOD and WHITEHEAD.
Modification of "Noble" comb substituting gill for small circles using "nip" feed.
1617. June 4, 1870. ODDY, J., and WHITEHEAD, H. W.
Produce of large and small circles separately delivered.
2356. August 27, 1870. TONGUE, WM.
Improvements on Drevelle 60 of 1854 and 13,977 of 1852.
2538. September 22, 1870. BAILEY, ISAAC.
Conical rollers for drawing-off belts.
2691. October 12, 1870. TAVERNIER, L. F. (TAVERNIER, E.)
Improvements on 2832 of 1866.
2854. October 28, 1870. ROBERTSHAW, J.
Disc studs and gills peculiarly applied, revolving brush therewith, comb to clean same, jaw coöperates.
3293. November 16, 1870. MIRFIELD, M. and SCOTT, J.
Improvement on 2601 of 1866. Operation by oscillating comb, feed comb and dabbing brushes.
48. January 9, 1871. NASMITH, JOHN.
Improvements in making bobbins for laps and in lap detaching mechanism and top rolls of "nip" machine.

195. January 25, 1871. WHITEHEAD, T.
Operating feed boxes by incline fixed above rack circle : stroking and clearing mechanism.
213. January 26, 1871. WHITEHEAD, H. W. and ACKROYD, R.
Improvements in drawing-off.
480. February 23, 1871. WHITEHEAD, T.
Feeding balled fibre by positive motion. Driving balling motion frictional. Small additional circular comb to Noble machine.
902. April 5, 1871. SMITH, J. B. and H. and BRADLEY, C.
Double outer ring one part in movable segments.
938. April 10, 1871. BAILEY, W. H.
Porcupine co-operating with curved bar to feed. Detaching comb in nip machine : draw off : Tweedler.
938. April 10, 1871. BAILEY, W. H.
Porcupine co-operating with curved bar to feed actuating gill bars in square motion comb ; two sets of pushers.
1297. May 13, 1871. LITTLE, G. and EASTWOOD, T. C.
Series of intermittent revolving nipper jaws co-operating with travelling comb.
1683. June 27, 1871. CROFTS, J., DAWSON, R., and KING, J.
Improvement on Noble 894 of 1853. Positive and relative pressure to fibre at delivery end of feed box.
1865. July 17, 1871. SMITH, J. B. and H. and BRADLEY, C.
Extension of 902 of 1871 to silk and cotton.

2518. September 23, 1871. EASTWOOD, T. C.
Carding, combing and slivering direct without preparing.
3076. November 15, 1871. KOCHS, W. E.
Modifications of Heilmann's machine.
23. January 2, 1872. WHITEHEAD, H. W.
Dispensing with weight lids of feed boxes and applying press rollers.
44. January 5, 1872. HOLDEN, E.
Altering lengths and fineness of teeth in circle.
117. January 15, 1872. FRANCE, W. H.
Additional circle of teeth between inner and outer circles ; also knives to nip. Improvements on 2104 of 1862, 3276 of 1868, 3241 of 1869, 3293 of 1870, 902 of 1871.
700. March 7, 1872. SMITH, B., STAKE, J., TOLSON, R., FIRTH, M., and BRADLEY, C.
Nipping jaws employed extra of the ordinary ones.
862. March 21, 1872. JEFFERSON, J. C. L. and M.
Clearing the fibre at part where laid on the circles ; rings between teeth of circle to ensure action of clearing comb and lifting knives, construction of lifting knife and boxes.
850. March 20, 1872. LITTLE, G.
Actuating detaching rollers.
904. March 24, 1872. LITTLE, G. and EASTWOOD, T. C.
Improvements on 2518 of 1871. Workers and feed apparatus.

1114. April 15, 1872. TONGUE, WM.
Improvements on 2356 of 1870.
2047. July 6, 1872. CROFTS, J. and DAWSON, R.
Improvements on 1683 of 1871. Applying teeth to feed trough end.
2285. July 30, 1872. WHITEHEAD, T.
Clearing top side portion of sliver by knives before it reaches tangent point to lay between large and small circle.
2737. September 14, 1872. RUSHTON, T. H., MAC-QUEEN, J.
Improvements on Heilmann 11,013 of 1846, actuating piecing roller facilitating adjustment of nip and feed.
3139. October 23, 1872. LISTER, S. C.
Improvements on 2823 of 1859 and modifications.
3615. November 5, 1872. ANDERTON, S. B. and GOULDING, J.
Single funnel directing four sliders from draw-off to "balling" head.
3906. December 24, 1872. GARNETT, W. T., and WHEATER, J. and WARING, W.
Toothed guard to dabbing brush.
3918. December 24, 1872. WHITEHEAD, H. W.
Simplifying arrangement and reducing wear and tear. Traversing endless drawing belts. Applying rotating nib. Improvements on 2285 of 1872. Deep rib to underside of feed box.
670. February 22, 1873. TONGUE, WM.
Improvements on 2356 of 1870 and 1114 of 1872.

839. March 7, 1873. LITTLE, G. and EASTWOOD, T. C.
Improvements on 1297 of 1871. Flexibility to cams operating jaws, clearing comb to gill feeding head ; divider between feeding head and nipping jaws ; stop motion.
969. March 15, 1873. SHEPHERD, H. W. and SCOTT, J.
Clearing noil ends of tufts.
2082. June 12, 1873. MIRFIELD, M. and SCOTT, J.
Fixed intercepting knife. Fibre holding and drafting disc
Compensating and adjusting apparatus.
2189. June 23, 1873. WHITEHEAD, T. and H. W.
Drawing-off top from inner side of small circle where the large and small circles meet, and another top from the outer side of same.
3304. October 11, 1873. TONGUE, WM.
Improvements on 2356 of 1870.
4233. December 24, 1873. MIRFIELD, M. and SCOTT, J.
Recombing short fibre. Attaching cam to circle.
299. January 23, 1874. LISTER, S. C.
Silk waste and wool. Improvements on 1727 of June 28, 1866.
573. February 14, 1874. MIRFIELD, M. and SCOTT, J.
Extra small circle to recomb.
762. March 2, 1874. LITTLE, G. and EASTWOOD, T. C.
Drawing rollers to co-operate with porcupine rollers. Each porcupine roller movable on its axis.
1706. May 14, 1874. LOHREN, A.
Larger inner circle.

-
2063. June 13, 1874. LISTER, S. C.
Improvements on 3139 of 1872 and 299 of 1874.
2344. July 4, 1874. WHITEHEAD, H. W.
Serrating delivery ends of feed boxes.
3123. September 11, 1874. HOLDEN, EDWARD.
Taking fibres from gill combs in nip machines.
3213. September 19, 1874. LITTLE, G. and EASTWOOD,
T. C.
Improvement on 904 of 1872. Feed, workers, doffing brush,
travelling card, drawing-off dust and noil.
3388. October 3, 1874. PRIESTMAN, E. and CROOK, W.
Corrugating nipping jaws to retard sliver passing through feed
boxes.
4395. December 21, 1874. FAIRBURN, R.
Dispensing with second pair of drawing off-rollers, drawing-off
beard with nipping rollers.
104. January 12, 1875. FRANCE, W. H.
Double set of teeth to circular combs. Closing runners fitted
within cam acting on drawing leather and sliver.
480. February 9, 1875. BRADLEY, C. and CAMPBELL, J.
Circular nips between large and small circle combs inside instead
of outside circle.
1341. April 13, 1875. CURE, J. and BRADLEY, C.
Doubly operating on whole length of fibre.

2292. June 23, 1875. RUSHTON, T. H., DOBSON, B. A., and MACQUEEN, J.

Construction of comb cylinder, adjustment of detaching roller ; construction of top comb connecting nipper arm and connecting rod.

2641. July 24, 1875. WALMSLEY, S. V.

Peculiarly shaped knives to dispense with drawing-off rollers of noil from small circle comb.

123. January 11, 1876. BAILEY, J. and SMITH, D. and L.

Extra circular comb with reversely pointing teeth working outside circular comb.

254. January 27, 1876. HETHERINGTON (PÉNEL, M. P. A., and LE CŒUR, E. G. G.)

Improvements on 651 of 1873 : rotary clamp and current of air.

365. January 29, 1876. WHITEHEAD, H. W.

Noil conductors.

365. January 29, 1876. WHITEHEAD, H. W.

Improvement on 1084 of 1865.

479. February 6, 1876. MIRFIELD, M. and SCOTT, J.

Enlarging smaller inner circle combs.

1248. March 23, 1876. SMITH, D. and BAILEY, J.

Cleaning nipping jaws.

1402. March 31, 1876. LISTER, S. C.

Improvement on 2832 of 1859.

-
1388. March 31, 1876. CLOUGH, J.
Intersecting comb guard plate.
1444. April 4, 1876. BATTINSON, G. and J.
Dabbing wipers instead of brushes.
2264. May 30, 1876. ACKROYD, R. G.
Dabbing mechanism and circle cleaner. Intersecting inverted comb.
2313. June 1, 1876. DE PASS, E. (IMBS).
Improvements on 10 of 1869.
2322. June 2, 1876. JOHNSON, J. H. (MEUNIER and GRÜN).
Improvements on 10 of 1869.
3469. September 2, 1876. KELLY, P.
Intersecting rod : cleaning same.
3595. September 14, 1876. HOLDEN, J. E. and I.
Applying supplementary comb.
4252. November 3, 1876. BRADLEY, C. and CAMPBELL, J.
Circular nip ; improvement on 480 of 1875.
4835. December 14, 1876. LE CŒUR, E. J. J.
Improvements on 651 of 1873 and 254 of 1876. Driving cylinder : working rotatory clamps.
184. January 13, 1877. CLARK, A. M. (HEILMANN-DUCOMMUN, and STEINLEN).
Improvements on 49 of 1877.

710. February 21, 1877. HOYLE, C.
Dispensing with lifting pins for lifting feed boxes.
715. February 21, 1877. FREEMANTLE, C. and
DUGDILL, J.
Traversing motion to stripping brushes.
1249. March 29, 1877. WALKER, J. C. and STEVENSON,
J. and J.
Porter combs and draw-off leathers, knife for protecting combs,
doffers and pressing plate motions.
1318. April 4, 1877. WHITEHEAD, H. W.
Equalising pressure on drawing-off rollers, dabbers, and
actuating same.
1696. May 1, 1877. WRIGHT, F. H.
Changing surface of apron when doffing.
1897. May 15, 1877. BEECROFT, R. and WRIGHT, F. H.
Segmental comb apparatus with pins or teeth for circular combs
to dispense with dabbling brushes.
1978. May 19, 1877. BROWNE, A. (OVEREND, T. and
FIRTH, T.)
Cleaners for the combs.
2328. June 14, 1877. SPEIGHT, T. and R.
Actuating dabbling brushes.
2529. June 14, 1877. BROOK, G. and STAKE, J.
Leathers for drawing-off and joining.

2761. July 19, 1877. FOSTER, H. A.
Lifting noil, &c., out of travelling comb for recombining.
2910. July 30, 1877. CLARK, W.
Substitution of rotating depressing discs for dabbing brush.
3600. September 25, 1877. LISTER, S. C.
Straight nips in continuous linked pairs of grooved blocks.
3345. September 3, 1877. JOHNSON, T. F.
Cleaning narrow bands near ends of slivers.
3783. October 12, 1877. JEFFERSON, C. L. M., and J.
Combinations of circular combs and circular nippers for combing ends.
3889. October 20, 1877. BROOK, G. and STAKE, J.
Star wheels in lieu of dabbing brushes.
4508. November 29, 1877. CLARK, A. M. (HEILMANN-DUCOMMUN, and STEINLEN).
Improvements on 184 of 1877.
4705. December 11, 1877. BEECROFT, R. and WRIGHT, F. H.
Segmental comb : pressing blades instead of teeth. Improvement on 1897 of 1877.
583. February 12, 1878. WHITEHEAD, C.
Mounting and working dabbing brushes, conductors for drawing off leathers.
1128. March 21, 1878. BROWN, A. (OVEREND, T. and FIRTH, T.)
Preventing breaking of fibre and formation of noil. Improvement on 123 of 1876.

1271. March 30, 1878. FREEMANTLE, C., and DUGDILL, J.
Rotary nippers : cushion plates for same.
1294. April 2, 1878. DENBY, D.
Circular dabbing brush.
1335. April 4, 1878. HADDON, R., DYSON, J. and ASTIN, E.
Adjustable travelling cleaning belt.
1643. April 24, 1878. CLARK, A. M. (HEILMANN-DUCOMMUN, and STEINLEN).
Feed ; nippers ; cleaning web and combs.
1900. May 11, 1878. ROSS, J. and PEARSON, C.
Wire dabbing brushes.
1956. May 15, 1878. HÜBNER, E.
Differential gear ; feed ; combs, and noil stripping mechanism.
2191. May 31, 1878. LISTER, S. C.
Filling mechanism. Improvements on 3600 of 1877. Nipping head and two travelling straight endless combs.
2628. July 1, 1878. BROOK, G., SYKES, J. and STAKE, J.
Arranging three small combs : Dividing mechanism. Improvement on 3889 of 1877.
3165. August 10, 1878. TERRY, W. and SCOTT, J.
Rollers in lieu of dabbing brushes.
3213. August 14, 1878. SCOTT, R. and HANSON, J.
Pressing fibres into circle. Keeping noils behind.
3344. August 24, 1878. FEARNLEY, W. and DRACUP, R.
Back combing and cleaning mechanism.

3457. August 31, 1878. HOLDEN, ISAAC.
Segmental circles, oiling same; heating teeth; bearing for and oiling driving screw.
3473. September 2, 1878. IMBS, J.
Nippers and comb holders: clothing upper seizing roller. Improvement on 2313 of 1876.
3836. September 28, 1878. CLARK, A. M. (HEILMANN-DUCOMMUN, and STEINLEN).
Cleaning combs differential motion for parting nipper. Improvements on Patents of January 83, 1877, No. 184, and November 29, 1877, No. 4508, and April 24, 1878, No. 1643.
4368. October 29, 1878. GUY, R. (MATIEU, E.)
Combing silk waste and waste from combed wool, &c.
4416. November 1, 1878. ABEL, C. D. (MEUNIER.)
Cylindrical extra noil comb.
4985. December 5, 1878. KAY, T. B.
Feed mechanism: improvements on patent of January 13, of 1873.
5200. December 18, 1878. MURDOCH, H. H. (ROUGET).
Modifications of Heilmann comb.
294. January 23, 1879. DE PASS (FRUXLER.)
Feed, nip, workers and general arrangement.
443. February 4, 1879. HOLDEN, ISAAC.
Heating teeth; operating clearing combs; pressing on and oiling comb circle.

-
542. February 11, 1879. DE PASS (IMBS, J.)
Combing sliver head and cleaning combs nippers and combs.
547. February 11, 1879. CLARK, A. M. (HEILMANN-DUCOMMUN AND STEINLEN.)
Nippers with movable fingers on lips and gill feed boxes.
625. February 14, 1879. TERRY, W. and SCOTT, J.
Arrangement of larger and smaller combs, and feeding same.
904. March 1, 1879. BAILEY, J.
Operating transfer comb and dabbing brush.
846. March 3, 1879. HOLDEN, ISAAC.
Operating keeping plate for holding fibre whilst being operated on by working combs in square motion.
1460. April 9, 1879. GADDUM, T. (HELME).
Travelling nipping blocks or books ; carding drums and nipping blocks.
1771. May 5, 1879. MEWBURN, J. C. (A. PROUVOST ET CIE.).
Double combing ; feed and collector mechanism ; quadrangular feed instead of elliptical feed.
2327. June 12, 1879. PERRY, C. L.
Feeding, doffing, and nipping mechanism. Improvements relating to the "Imbs" system.
2346. June 13, 1879. WALKER, J. C. (POLLET, POLLET and PEGLER).
Heating and retaining heat of the nacteur combs of the square motion.

2582. June 26, 1879. RUSHTON, T. H., DOBSON, B. A., AND W.

Detaching and piecing up the fleece.

2637. June 30, 1879. WHITEMAN, W. (NOUGIER.)

Drawing and winding mechanism.

3468. August 28, 1879. CURTIS, R. AND BARKER, T.

Feed motion, actuating nipper and combs, stripping combs.

3568. September 5, 1879. CLARK, A. M. (HEILMANN-DUCOMMUN AND STEINLEN.)

Laying fibres for piecing up, separating fibres and arranging nippers. Improvements on 184 of 1877, 4508 of 1877, 3836 of 1877, and 547 of 1879.

3889. September 27, 1879. CLARK, A. M. (BOURCART, FILS AND CIE.)

Nipping, combing &c., mechanism.

4164. October 14, 1879, BAILEY, J. and FIRTH, T.

Feeding tufts, separating and cleaning noils.

4375. October 27, 1879. CLARK, A. M. (DUJARDIN, A. D. R.)

Fibre detachment and nipping mechanism for Heilmann machine.

4545. November 7, 1879. LITTLE, G. and EASTWOOD, T. C.

Mounting and operating gills and dividers, friction clutch. Improvements on 839 of 1873. Revolving nipping jaw.

4911. December 1, 1879. THORNTON, J. W. and HOYLE, C.

Dabbing brush, press rollers and gear.

5012. December 6, 1879. RUSHTON, T. H. and DOBSON, B. A.

Nipper knife and cushion plate for Heilmann comb.

5019. December 8, 1879. LISTER, S. C.

Filling heads. Improvements on 2191 of 1878.

2234. June 1, 1880. DE PASS, E. (IMBS.)

Nippers, comb-holder, and differential oscillatory motion. Improvements on 10 of 1869, 2313 of 1876, 3473 of 1878, 542 of 1879, 3871 of 1879, 64 of 1880.

3422. August 24, 1880. JOHNSON (TRUXLER).

Feeding and stripping off.

4020. October 4, 1880. HEATON, J.

Fallers with clearing blades to lessen rubbings in square motion combing.

4673. November 13, 1880. HETHERINGTON, J. M.

Nip mechanism, weighted top rollers.

5369. December 22, 1880. SMITH, A.

Additional nip to large circle combs to increase "top" and lessen noil.

64. January 7, 1880. DE PASS, E. (IMBS.)

Feeding, differential oscillating motion. Improvements on 3874 of 1879, Imbs' system.

1279. March 23, 1881. HOLDEN, ISAAC.

Inclined channel for escape of lubricant.

1347. March 26, 1881. MIDGLEY, J.

Intersecting combs to square motion.

2009. May 9, 1881. HARRISON, JOHN F.
Combining, nipping, &c., mechanism in circular combs for converting "fringe" into "top."
2373. May 30, 1881. LISTER, S. C.
Combing and drawing at one operation. Improvement on 2191 of 1878. Endless aprons, two nipping surfaces.
2713. June 21, 1881. WALKER, J. C. and STEPHENSON, J. E.
Feeding mechanism.
2736. June 22, 1881. BALDWIN, J. and W.
Dabbing brushes, frictional driving.
3019. July 9, 1881. MOSS, W. R.
Comb cylinder for clearing waste in rollers and preventing roller caps and condensing sliver.
3048. July 12, 1881. BARLOW (BAUDOIN).
Forming sliver, porcupine cylinder and driving gear. Hubner's system.
243. July 25, 1881. LITTLE, G.
Mounting and operating dabbing brush for combing noil.
3480. August 11, 1881. HEATON, I.
Gill head and backing motion.
3726. August 26, 1881. DE PASS, E. (IMBS).
Nippers, stop motion, actuating nippers, finishing comb, etc. Improvements on 10 of 1859, 2313 of 1876, 3473 of 1878, 542 of 1879, 3814 of 1879, 64 of 1880, 2234 of 1880.
4125. September 24, 1881. HARRISON, J. F.
Preventing fringe, circular combs with nipping mechanism.

4464. October 13, 1881. TERRY, W. and SCOTT, J.
Feeding detached tufts. Improvement on 625 of 1879.
4734. October 29, 1881. MARSDEN and PENDLEBURY.
Multiplying action and cams.
5089. November 21, 1881. SMITH, A. and FIRTH, M.
Feed mechanism setting pins vertically in combs. Feeding
"Noble" comb by circular "nip."
5330. December 6, 1881. DOBSON, B. and MACQUEEN, J.
Nipping detaching and piecing: construction of cylinder and
combs.
881. February 23, 1882. LAKE (GRUNDY, W. H. of
Bristol, Penn).
Aprons co-operating with guide.
2040. April 29, 1882. HARDING, J. W. (PEGLER).
Improvement on 2346 of 1879. Flanged steam box for heating
nacteur combs.
2388. May 20, 1882. ABEL, C. D. (GLASER, F. C.)
Heilmann or Schlumberger type or variety. Feed mechanism.
2600. June 20, 1882. HAIGH, J., DEAN, W. and
MITCHELL, T. F.
Dabbing mechanism.
3088. June 30, 1882. BRADLEY, J. W. and WOOD, J.
Arrangements of intermediate circular receiving comb or
intermediate feed comb and two outer receiving combs.
3202. July 6, 1882. FAIRBANK, F. and ROBERTSHAW, J.
Rotating discs to press in fibre to circles.

3833. August 11, 1882. LITTLE, G., EASTWOOD, T. C., GREEN, J. and FLETCHER, J.

Improvement on 839 of 1873, 4545 of 1879. Feeding head, nipping jaws, divider, preventing waste of noil and condensing.

4360. September 13, 1882. WHARTON, T. H. and SMITH, R.

Dabbing mechanism.

4959. October 18, 1882. KELLY, P.

Improvements on 3469 of 1876.

5319. November 7, 1882. WHITEHEAD, J. H.

Improvement on 2328 of 1877 (Speight).

5958. December 13, 1882. WHITEHEAD, J. H.

Divides feed knife : Guides to wool to feed boxes.

6125. December 22, 1882. TERRY, W. and SCOTT, J.

Noble with nip feed and gill bars.

691. February 8, 1883. FAIRBANK, F.

Sectional brushes for dabbing.

711. February 9, 1883. HOLDEN, JONATHAN, BURNLEY, J. and FAWELL, J.

Stop motion to Noble Comb.

1740. April 6, 1883. PORTWAY, H. and WALKER, J. C.

Dabbing brushes.

1806. April 10, 1883. WALKER, J. C.

Vitreous coating to conductors of silver.
Dabbing brushes.

-
2109. April 26, 1883. THOMPSON, J. and BARKER, T.
Three pairs of nips and one combing cylinder.
2761. June 4, 1883. DE PASS, (IMBS, JOS. of Paris.)
Improvements on Imbs' system.
3248. June 30, 1883. WHITEHEAD, J. H.
Locking roller stands.
3426. July 12, 1883. WHITEHEAD, J. H. (PROVOST, A.)
Dabbing plates in combination with dabbing brushes.
3871. August 9, 1883. PRIESTMAN, H., ADCOCK, F. K.
and BROWN, J.
Stop motion.
4353. September 11, 1883. DOBSON, WM.
Oscillating combing machine, dish feeder and roller, oscillating
segment, feeders.
4777. October 9, 1883. HOYLE, C.
Vertical draw-off to Lister's comb.
414. January 2, 1884. WALKER, J. C.
Feed rollers of corrugated metal. Intermittent rotation imparted
to feed rollers by arm acting on flange at each approach of
head. Gearing pinions of drawing off rollers concealed in
bearing.
502. January 3, 1884. POLLARD, F. T.
Brush in two parts speeded differently. Two rising and falling
brush motions at different speeds.

2706. February 5, 1884. POLLARD, F. T.

Machine with three or more inner circles, inclines formed on a ring, belt and wheel gearing for driving brushes in machines with three or more inner circles.

3312. February 14, 1884. GARNETT, W. T. and WHEATER, J.

Hollow steel or iron sliding rods passing through suitable guides. Improvements on 2328 of 1877. Speight's dabbing brush.

3747. February 22, 1884. PRIESTMAN, H. and ROBERTSHAW, J.

Dabbing brush in two parts, one adjustable for wear.

4975. March 15, 1884. FEARNLEY, WM. and DAVY, J.

Curved comb with clearing arrangements applied between gills and nip in Lister's machine.

6335. April 12, 1884. CLARK, A. M. (HEILMANN-DUCOMMUN and STEINLEIN).

Rubber pressing in roller and comb cylinder of varying radius having bars to break straws, &c.

6870. April 26, 1884. GARNETT W. T. and WHEATER, J.

Brush carried by light steel web, side tubes sliding on hollow pillars.

7179. May 3, 1884. GAUNT, J. W.

Stop motion.

8446. May 30, 1884. HODGSON, GEO.

Drawing-off spindles lubricated by suet, &c., placed in receptacles on sides of brushes.

12,746. September 24, 1884. MIDGLEY, J. and BEANLAND J. E.

Nipping segments applied to internal feeder close to comb circle. Improvement on 3088 of 1882. (Bradley and Wood.)

12,986. September 30, 1884. BRADLEY, J. W.

Internal circular feeder with inclined axis and nipping segments at base. Improvement on 3088 of 1882. (Bradley and Wood.)

13,839. October 20, 1884. JEFFERSON, J. C. L. and M.

Brushes started a little before and stopped a little after remainder of machine.

14,174. October 27, 1884. MIDGLEY, J. and BEANLAND J. E.

Nipping segments applied to internal feeder, close to teeth of comb circle.

15,195. November 19, 1884. HATTERSLEY, E. G. and HIRD, S.

Pressure of feed box lids relieved when opposite drawing-off rollers.

15,245. November 19, 1884. WALKER, J. C.

"Noble" machine with light parts and one pillar only, slider guides and feed boxes of sheet metal. Creel rollers intermittently rotated by contact of serrated bobbin flanges with levers. Non-conducting sheets placed between steam chests and parts attached thereto. Brush stocks of ebonite; crank underneath table: parts lubricated by crank dipping into oil well.

15,330. November 21, 1884. CALVERT, H.

Slide actuated by cam, spiral spring effecting return.

16,013. December 5, 1884. LISTER, O. B. and BATTY, H.

Slide actuated by conical cam on shaft with conical necks. Also means of lubrication.

8607. 1884. TERRY, W. and SCOTT, J.

Tufts drawn from gills by jaws, dabbed into large circle, fringe combed by small circle. Improvements on 625 of 1879, and 6125 of 1882; also on 4464 of 1881.

273. January 8, 1885. WALKER, J. C.

Steam chest under inclines of circle comb; circular rack and pinion with helical teeth. Drawing-off rollers geared together by helical wheels; adjustable stop to prevent draw-off leathers being pressed too closely together.

1407. January 31, 1885. WHITEHEAD, J. H. and BEST, J.

Inwardly projecting fringe operated on by an auxiliary comb prior to being dabbed into small circle.

5302. April 29, 1885. RICHARDSON, J. J.

Actuating dabbing brush by electrometer condensers placed in circuit.

5378. May 1, 1885. MIDGLEY, J. (of Pawtucket, U.S.A.)

Rod between comb and drawing-off roller to gather in projecting fibres.

6137. May 19, 1885. LAKE (SIMMONDS).

Short fibres from Heilmann's machine condensed to sliver and passed to flyer spindle or coiler.

7797. June 26, 1885. UNWIN, F.

Fixed blades prevent fibre rising after being dabbed into small circle. Hinged pressing-in blades for large circle, back portions remaining within teeth, and independent dabbing brush.

8150. July 6, 1885. GREENWOOD, W. H. and FARRAR, F.

Additional fluted roller to prevent lapping of uncovered drawing-off roller.

8378. July 11, 1885. DUGDILL, J.
Two cylinders, swinging and revolving nippers, tufts accumulated at delivery.
9009. July 27, 1885. GREENWOOD, W. H. and FARRAR, F.
Shaft of eccentrics for traversing draw-leathers accelerated at dead points.
- 11,392. September 24, 1885. WILKINSON, G.
Fibre drawn in plane of feed box by rollers only, oscillating plate supporting and guiding fringe.
- 12,094. October 12th, 1885. CLARKSON, EDWARD.
Gill fallers. A radial or curved recess formed in the sides of the fallers.
- 12,406. October 17, 1885. BENN, A.
Feed-knife carried by sliding plate adjusted by screw eccentric, &c.
- 13,167. October 31, 1885. CLOUGH, J. and WALKER, J. C.
Tank and wick for lubricating operating crank while in motion.
- 13,212. November 2, 1885. HOLDEN, ISAAC.
Push bar of square motion arranged to bear on whole length of comb bar.
264. January 7, 1886. TERRY, WM.
Improvement on 625 of 1879, supplies means of draw-off not shown therein.
877. January 20, 1886. SHARP, J. B. and MEDCALFE, S.
Dabbing brush and retaining plate.

-
6371. May 11, 1886. BRADLEY, J. W.
Improvement on 12,986 of 1884.
7398. June 2, 1886. WHITEHEAD, J. H.
Cast brass feed boxes.
8315. June 23, 1886. STELLING, G. (of Hanover.)
Arrangement of feeding, &c., devices.
8416. June 26, 1886. SPEIGHT, T.
Steam chest ; drawing-off rollers ; bearings and guides.
- 10,091. August 6, 1886. LISTER, J. and BROWN, T.
Construction and arrangement of circular dabbing brushes.
- 10,357. August 12, 1886. CLARK, A. M. (Société Bourcart
Fils and Cie.).
Improvements on Heilmann machine.
- 11,736. September 15, 1886, CARROLL, J.
Gill stock provided in front of usual faller dabbing brush.
- 12,309. September 28, 1886. MILLS, B. J. B. (CASSE, A.)
Continuous clamps linked.
- 15,635. November 30, 1886. WHITEHEAD, J. H.
Rollers and stands.
724. January 17, 1887. BRADLEY, C. and RICHARDSON, J.
Arrangement of combs.

1221. January 26, 1887. SMITH, A.
Recess between pins in large circle in which works an additional comb.
1529. February 1, 1887. WILLIS, T.
Two flanges to combing cylinder.
2539. February 18, 1887. DRABBLE, A. W.
Securing uniformity of traversing of drawing-off leathers.
3665. March 10, 1887. PICKLES, J. and WHITEHEAD, H. W. (TAYLOR, WORDSWORTH and CO.)
Heating, reducing wear of rack circles, and reducing drawing strain.
3905. March 15, 1887. ILLINGWORTH, A. H. and H. H.
Keeping plates.
4769. March 30, 1887. HAMILTON, W. R.
Presser blades to press wool into both circles.
9432. July 4, 1887. MCQUEEN, J. and MOORES, W.
Actuating nippers.
9989. July 16, 1887. HOLDEN, ISAAC.
Additional supporting rollers to press against draw-off rolls to prevent bending.
- 10,386. July 26, 1887. BAILEY, W. H.
Dabbing brush meeting.
- 12,142. September 8, 1887. GAUNT, E. and COCKCROFT, W. H.
Duplicate and triplicate dabbing brushes

13,689. October 10, 1887. FIRTH, J. W. and SHACKLETON, M.

Operating the feed-knives of combing machines.

15,809. November 18, 1887. WHITEHEAD, H. W. and J. H. (TAYLOR, WORDSWORTH and Co.)

Gradually diminishing length of pins in rows away from the point of tangence of the two circles in "Noble" comb.

INDEX.



INDEX.

A.

ACKROYD, R. G. 457
 African sheep, 11, 17
 Akroyd, Colonel, 218
 Akroyd, Messrs. 260
 Alfred the Great, as a spinner, 44
 Alston woolcombing works, Bradford, 91-104, 323, 368
 Amatt, Anthony, 138, 422, 424
 Ambler, J. 433
 American sheep, 13
 "Amicus" in *Bradford Observer*, 376
 Anderton and Goulding, 453
 Anderton, G. 424
 Angola sheep, 11
 Appendix of woolcombing inventions, 421
 Arabs in Europe, 56
 Archer, Professor, on sheep, 10
 Arete, Queen, 44
 Argali, 9, 12
 Argentine sheep, 29, 419
 Arkwright, 110
 Ash and Whitley, 446
 Asiatic sheep, 10
As You Like It, reference to, 417
 Augustus Cæsar, 44
 Australia, introduction of sheep into, 23
 Australian colonies, 419
 Austria, sheep in, 27

B.

BABYLON, manufactures in, 41
 Bailey, Isaac, 450
 Bailey, J. S. 428, 430, 434, 438-440
 Bailey, W. H. 451, 474
 Bakewell, Mr. and the new Leicester, 15

Baldwin, Earl, and Flemish weavers, 57
 Baldwin, J. and W. 465
 Baldwin, Wood, and Crossley, 441
 Banks, Sir Joseph, and the merino, 18
 Baring, John, 426
 Barwell sheep, 11
 Basil, Emperor, 44
 Bateman, Mr. Daniel, 369
 Bateman, S. 444
 Battinson and Whitehead, 449
 Bazley, T. 430
 Bearded sheep of West Africa, 11
 Beecroft and Wright, 458, 459
 Belgium, sheep in, 28
 Benn, A. 472
 Bernier and Fils, MM. 301
 Berry, Miles, 426
 "Big Ben," Cartwright's, 117, 165
 Binns and Pollard, 435
 Blaize, Bishop, 53, 166, 186, 210
 ode to, 197
 song of the new, 126
 celebrations, 125, 166, 186-210
 Bonwick, Mr. James, on the allegory of the Golden Fleece, 52
 Bourcart, J. J. 217, 430
 Bousfield, G. T. 442, 447
 Bowman, Dr. on wool, 4-6
 Brabant, wool manufactures in, 48
 Bradford, Alston woolcombing works at, 91-104, 323
 Chamber of Commerce, 413
 Town Hall, opening, 207
 Woolcombers' Association, 175, 179
 Bradley, C. 408, 451, 452, 455, 457, 473
 Bradley and Wood, 466, 470, 473
 Brazilian sheep, 12
 Breeds of sheep, 6, 8

- British North America, sheep in, 28
- Broad-tailed sheep, 11
- Brookes, W. 439, 446
- Brooman, R. A. 445-448
- Brown, H. 435
- Brussels, manufactures in, 58
- Buenos Ayres wools, 29, 96
- Bulmer and Bailey, 436
- Burgess, T. on wool, 4
- Burnett, Mr. Henry, 179
- Burring apparatus, 100
roller, 369
- Burrs in wool, 96, 369
- Busfield, W. 408, 431
- C.
- CAGO sheep, 10
- Calvert, H. 470
- Campbell, J. 455
- Canada, sheep in, 28
- Carding, 357, 368
- Cartwright, Dr. Edmund,
his first attempts at machine wool-
combing, 106
early life, 107
as a poet, 108
marriage and settlement at
Brampton, 110
visit to Matlock, 110
his power-loom, 111
his woolcombing machine, 113,
122
statement of, regarding wool-
combing, 114
his "Big Ben," 117, 165
bankruptcy of, 129
lawsuits, 129
petition to Parliament, 129
grant to, 133
later scientific pursuits, 132
death, 133
on patents, 134
- Cartwright era, the, 105-141
- Cato's garments, 41
- Catullus on wool spinning, 45
- Chamber of Agriculture, 413
- Charlemagne's spinning schools, 57
- Charles I. and the wool trade, 74
- Child, Sir Josiah, on wool, 77
- Chinese sheep, 11
- Cholesterin*, 6
- Clark, W. 440
- Clarkson, Mr. Edward, 410, 472
- Clothiers' Delight, the ballad of the,
161
- Clough, J. 457
- Colbert, 76
- Collier, James,
his patent of 1814, 146, 424
bird's-eye view of his machine,
147
further drawings of same, 148-150
- Collier, Madame, 301
- Combination laws, 164, 168
- Common sheep, 10
- Congo sheep, 11
- Coraxi, the, 42
- Cotswold, the, 15
- Cowper, C. 407, 409, 430, 433, 435,
440
- Cowper, E. A. 437
- Crabtree, Mr. Samuel, 407, 436
- Craig, Mr. Thomas, 346
- Cretan sheep, 10
- Crimean sheep, 10, 27
- Croft and Steel, 439
- Croft, Mr. John, 277
- Crofts, Dawson, and King, 448, 449,
451, 453
- Crook, W. 455
- Crothers, Mr. J. H. 323
- Crusades, the, 56
- Cure and Passavant, 435
- Cure, J. 455
- Curumbar sheep, 11
- D.
- DAMOSELL, WILLIAM, 69
- Dargue, J. 442
- Davies, E. 433
- Davison and Hawksley, 116
- De Jongh, C. 440
- Denby, D. 460, 466
- Denmark, sheep in, 27
- Denton, W. 435
- Derham, J. 435
- Deverte, L. A. 433
- Dimock, J. 444
- Dobson, B. A. 456
- Dobson, Wm. 468
- Donisthorpe, G. E.,
his first woolcombing experiments,
140
early life, 155
patent of 1842, 155, 427
association with Mr. S. C. Lister,
157, 415

Donisthorpe, G. E.—*continued.*

- patents of 1843, 427
 - patent of 1845, 428
 - and Heilmann, 220
 - and Lister, 273, 400
 - nip machine, 273
 - at the Exhibition of 1851, 273
 - and the Prince Consort, 273
 - and the Noble machine, 277, 376
 - in business at Hunslet, 277
 - death, 277
 - and Noble, 376
 - and Rawson, 425
 - and Whitehead, 429
 - and Crofts, 431
 - patent of 1859, 441
 - patent of 1864, 444
 - patent of 1865, 445
 - patent of 1866, 446, 447
 - patent of 1867, 447
- Drevelle, 434
- Dukhan, or Deccan sheep, 11
- Dyeing of wool, 73

E.

- EAST INDIA COMPANY and wool-growers, 73
- Eastwood and Joyce, 442
- Eastwood and Little, 410, 411, 451, 454, 455, 463
- Eastwood, T. C. 452
- Eastwood and Whitehead, 450
- Eastwood and Whitley, 437
- Edgar, King, and wool trade, 48
- Edward the Elder's daughters as weavers, 48
- Edward III. and the Flemings, 60
- Elizabeth, Queen, and the wool trade, 71, 74
- Ellis, on the Lincoln, 14
- Elmore, A., R.A. and his Heilmann picture, 218
- Ernouf, Baron, on Heilmann, 218
- Esterhazy, Prince, and the merino, 27
- European sheep, 10
- Exhibition of 1851, 185, 273

F.

- FAIRBAIRN and Greenwood, 435
- Fairbairn and Marshall, 434
- Fairbairn and Newton, 441
- Fairbank, Mr. 409

- Fairburn, R. 455
- Fawcett, Mr. Richard, 196
- Fearnley and Dracup, 460
- Feather and Driver, 430
- Fezzan sheep, 11
- Flanders, wool manufactures in, 48, 57
- Fleece, description of a, 7
- Flemish artisans in England, 49, 50, 60, 67
- Fletcher, W. S. 448
- Florentines, the, and the woollen manufactures, 58
- Foster, H. A. 459
- Fothergill and Weild, 435, 436
- Fothergill, G. 444
- France, sheep in, 26
- France, W. H. 448, 452, 455
- Fraser, Mr. John, 281
- Freemantle, C. and Dugdill, 458, 460
- Friesland, manufactures in, 58

G.

- GARAR sheep, 11
- Garnett, Mr. 170
- Garnett, Wheeler, and Waring, 453, 469
- Gaunt, John of, sheep presented by, 18
- Gaunt, J. W. 469
- Geller's improvements, 395, 408, 448
- Genappes, 371
- George III. and the Spanish merino, 20
- Germany, sheep in, 27
- Ghent, weavers of, 58
- Gilpin, George, his woolcombing patent, 145, 424
- Golden Fleece, legend of the, 53
- Golden Fleece, the*, of 1599, 61
- Goulding, J. 453
- Greenwood and Bapty, 449
- Greenwood and Farrar, 471, 472
- Greenwood and Warburton, 430
- Grimshaw, Messrs. 128
- Guilds, 55
- Guinea sheep, 11

H.

- HANDCOMBERS, decline and extinction of, 159
- in the 18th century, 159
- restrictions as to combinations by, 164, 185

- Handcombers in 1825, 166
 Union, 167
 great strike of, 167
 at Dolphin Holme Mill, 175
 great distress amongst, 176
 address of, 176
 extinction of, 184
 in France, 301
 Handcombing, 88
 Hargreaves, Wm. 433, 438, 443
 Harmel Frères, 100, 445
 Harrison, John F. 465
 Hattersley and Hird, 470
 Hawksley, John, 136, 140
 Heilmann-Ducommun, 457, 459, 460-463, 469
 Heilmann, Josué, 211
 early career, 211
 at Yverdun, 212
 commercial studies, 213
 in Paris, 213
 spinning at Vieux-Thann, 214
 marriage, 214
 invents embroidery machine, 216
 combing experiments, 217
 story of the first idea of Heilmann's
 combing machine, 217
 Baron Ernouf on, 218
 death, 222
 combing machine, 222, 399, 428
 Lohren on, 224
 patent rights, 240
 and Schlumberger, 400
 Hendry, T. 427
 Henry VI. and the wool trade, 70
 Hetherington, J. 432, 443, 448
 Hick, the Rev. John, 283
 Hindes and Derham, Messrs. 175
 Hindostan Dumba sheep, 11
 Hodgson, George, 469
 Holbrey, J. 434
 Holden, Burnley and Co.'s stop motion,
 394, 467
 Holden, E. 452, 455
 Holden, Isaac, and Sons, inauguration
 of firm of, 323
 Alston works of, 323, 368
 Holden, Mr. Angus, 337
 Holden, Mr. Isaac, M.P.
 estimate of his achievements, 370
 early career, 278
 scholastic attainments, 281
 first efforts as an inventor, 284
 and the lucifer match, 285
 evidence before Parliamentary
 Committee, 284
 Holden, Isaac—*continued*.
 at Reading, 286
 introduction to Mr. William
 Townend, 287
 engagement at Cullingworth, 288
 marriage, 291
 introduction to handcombing,
 291
 experiments with Collier's machine,
 293
 and genappe yarns, 294
 "Retrospective Notes," 294
 idea of the square motion, 295
 removal to Bradford, 296
 association with Mr. Lister, 299
 French partnership, 300
 starting business at St. Denis, 300,
 356
 at Rbeims and Croix, 321
 lawsuits, 322
 on wool washing, 413
 patent of 1856, 438
 patents of 1857, 438, 439
 patent of 1859, 440
 patent of 1860, 441
 patents of 1862, 443
 patent of 1865, 445
 patent of 1868, 448
 patent of 1878, 461
 patents of 1879, 461, 462
 patent of 1881, 464
 patent of 1885, 472
 patent of 1887, 474
 Holden, Mr. Jonathan, 100, 323,
 401
 Holland, manufactures in, 59
 Holland, sheep in, 27
 Homer on wool, 42
 Hooniah sheep, 10
 Hopkinson, W. 447
 Houldsworth, Henry, 432
 Hoyle, C. 458
 Hoyle and Preston's brush motion,
 394
 Hubner, Emil, 411, 439, 460
 Hungary, sheep in, 27

 I.
 ILLINGWORTH, Messrs. 409, 433, 436,
 439, 474
 Imbs, 448, 461, 464, 465
 Italy, sheep in, 27

- J.
- JACK OF NEWBURY, 69
- James I. and the exportation of wool, 71
- Javanese sheep, 11
- Jefferson, Messrs. 409, 446, 452, 459, 470
- Johnson, J. H. 432, 434, 437, 440, 450, 457
- Johnson, W. 432
- Joyce J. B. 440, 442
- Jubal, 35
- K.
- KELLY, P. 457
- Kochs, J. E. 452
- L.
- LANGHORNE, Dr. 108
- Languedoc, wool fabrics of, 59
- Lasteyrie on the merino, 18
- Lawson and Dear, 437
- Lawson and Fitton, 448
- Leather, G. H. 443
- Le Cœur, 456, 457
- Lecoq, J. 446
- Lee, William, and the stocking-frame, 73
- Leicester new sheep, 14, 15
- Leicester sheep, 14
- Libyans and their flocks, 42
- Liebach, Hartmann, 218, 219
- Lincoln sheep, 14
- Lister, Mr. G. T. 203
- Lister, O. B. and Batty, 470
- Lister's self-lubricating dabbling motion, 393
- Lister, Mr. S. Cunliffe,
 first sale of woolcombing machines, 183, 398
 and Heilmann, 220, 239, 251, 259
 and Donisthorpe, 242, 248, 273, 377, 429
 nip machine, 254, 273
 his nine combing-mills, 275
 and Holden, firm of, 300, 321, 358, 369, 401
 early career, 243
 partnership with his brother, 246
 trips to America, 246
 lawsuit with Heilmann's representatives, 260
 sale of share in French concerns, 322
 and Tongue, 411, 437
- Lister, Mr. S. Cunliffe—*continued.*
 patent of 1844, 427
 patent of 1845, 428
 patent of 1846, 428
 patent of 1847, 429
 patent of 1848, 429
 and J. Ambler, 430
 patent of 1853, 433, 434
 patent of 1854, 434
 patent of 1855, 437
 and Warburton, 441
 patent of 1872, 453.
 patents of 1874, 454, 455
 patent of 1876, 456
 patent of 1877, 459
 patent of 1878, 460
 patent of 1879, 464
 patent of 1881, 465
- Little and Eastwood, 410, 411, 451, 452, 454, 455, 463, 467
- Little, G. 408, 445, 447, 449, 450, 452, 465
- Lohren, Herr A. on Heilmann, 224
 on the nip machine, 261
 on the square motion, 360
 on the Noble machine, 378
 his improvements, 408
 on Little and Eastwood's machine, 410
 patent of 1874, 454
London Tradesman, The, 159
- Luccock, Mr. 79
- M.
- MACARTHUR, Captain, 23
- Macdonald, Dr. on the Leicester, 16
- Macqueen, J. 453, 456, 466, 474
- Madagascar sheep, 11
- Many-horned sheep, 11
- Marsden and Pendlebury, 466
- Marshall and Fairbairn, 434, 435
- May and Cowper, 437
- McLaren, Mr. W. S. B. on wool, 3
 on the Flemings, 50
 on the Noble machine, 386
- M'Culloch, Professor, 79
- Merchant adventurers, the, 75
- Merino Society, 22
- Merino, the, 5, 10, 17, 20, 21
- Middle Ages, manufactures in the, 54
- Midgley, J. 464, 470
- Miletus, wool of, 42
- Milligan, R. 431
- Mills, Isaac, and his patent for combs, 105

- Minerva, 44
 Mirfield and Scott, 447, 450, 454, 456
 Morel, A. 442-446
 Morocco sheep, 11
 Morris, 449
 Mortimer, S., 446
 Moss, W. R. 465
 Mowbray, F. W. 432
 Mysore sheep, 1
- N.
- NACTEUR combs, 353, 440
 Napoleon I. and the merino, 26
 Nasmith, John, 450
 Nepaul sheep, 10
 Nero, 41
 New Leicester sheep, 15
 New South Wales, 23, 24
 Newton, A. V. 428, 430
 Newton, W. E. 433, 441
 Newton, E. A. 438
 New Zealand, sheep in, 25
 Nip machine,
 Lister and Donisthorpe's, 301
 Heilmann's, 222, 240
 at 1851 Exhibition, 273
- Noble, James,
 his invention of 1805, 144, 373,
 423, 424
 his invention of 1834, 140, 425
 his invention of 1836, 426
 his invention of 1853, 373, 432
 his invention of 1852, 431
 and Donisthorpe, 376
 and Perry, 428
- Noble woolcombing machine, 373-
 395
 comb rings, 381
 machine, transverse section of, 382
 general view of, 385
 noil conductors, 390
 sheet conductor, 392
 spring-feed knife, 392
 self-lubricating dabbing
 motion, 393
 rack circle, 394
 Holden, Burnley & Co.'s
 stop motion, 394
 Speight's patent motion,
 394
 Hoyle and Preston's
 brush motion, 394
- Norfolk, worsted manufacture in, 50,
 66, 68
- Norway, sheep in, 27
 Nussey, N. 441, 442, 445
- O.
- ODDY, J. and Whitehead, 450
 Overend and Firth, 458, 459
 Ovid on wool-spinning, 45
Ovis Ammon, 12
Ovis aries, 9
Ovis musmon, 9, 12
 Owen, Professor, on wool, 2
 on sheep, 8
- P.
- PASSAVANT AND CURE, 435
 Passman, John, 138, 424
 Pennyoaks Mill, experiments at, 346,
 355, 369
 Perry and Noble, 428
 Perry, John, 427, 428
 Philip le Bon, 53
 Philippa, Queen, 65
 Pickles and Whitehead's rack circle,
 394, 474
 Platt Brothers, Messrs. 411
 Platt, John, 151, 425
 Platt-Collier combing machine, 151,
 399, 425
 drawings of, 152, 153
 Pollard, Mr. 409, 435, 468, 469
 Portugal, sheep in, 27
 Portway and Walker, 467
 Preller, C. A. 407, 427, 431
 Preller, Eastwood and Gamble, 431
 Priestman, Adcock, and Brown, 468
 Priestman, E. and Crook, 455
 Priestman, Messrs. and Robertshaw,
 409, 469
 Prouvost, A. 446, 447, 462
 Pyncha sheep, 11
- Q.
- QUEENSLAND, sheep in, 25
- R.
- RALEIGH, Sir Walter, and the woollen
 manufactures, 73
 Rambouillet, sheep at, 26

- Ramsbotham and Brown, 407, 429, 431, 436, 438
 Ramsbotham's combing machine, 294, 296, 428
 Ramsbotham, Mr. Robert, 127
 Rand, Messrs. 398
 Rand, Mr. John, 204
 Raw material, the, 1-33
 Rawson, Henry, 140, 439-441, 443
 Richard II.'s enactments regarding wool, 69
 Richardson, J. J. 471
 Roberts, R. 436
 Robertshaw, J. 450
 Romney Marsh sheep, 14, 26
 Ross's combing machine, 294, 407, 426
 Ross, Jesse, 427, 429, 431
 Rousillon, sheep at, 26
 Rouvier, M. and the merino, 27
 Rushton, T. H. 453, 456, 463, 464
 Russia, sheep in, 26
- S.
- SALT, TITUS, 260
 Sands, Turner and Co. 246
 Saracens in Europe, 56
 Saxony wool, 27
 Says, 51
 Schlumberger, 219, 400, 402, 406
 Scott, J. 447, 450, 454
 Scott, Sir Walter, on Dr. Cartwright, 109
 Scriven, Mr. John, and woolwashing, 413
 Seebohm, Henry, 434
 Sellars, William, 424
 Sellière, Mr. 369
 Sharp, D. W. 431
 Sheep, breeds of, 6
 African, 11, 17, 23
 allusions to, in the Bible, 35
 American, 13
 Angola, 11
 Asiatic, 10
 Australian, 23
 Barwell, 11
 bearded sheep of West Africa, 11
 Bengal, 23
 Brazilian, 12
 broad-tailed, 11
 Cago, 10
 Chine, 11
 common, 10
 Congo, 11
 Cotswold, 15
 Sheep, breeds of—*continued*.
 Cretan, 10
 Crimean, 10, 27
 Curumbar, 11
 Dukhan, or Deccan, 11
 Escorial, 17
 European, 10
 Fezzan, 11
 Garâr, 11
 Guadeloupe, 17
 Guinea, 11
 Hindustan Dumba, 11
 Hooniah, 10
 Infantando, 17
 Javanese, 11
 Leicester, 14-16
 Lincoln, 14
 Madagascar, 11
 many-horned, 11
 merino, 5, 10
 Montareo, 17
 Morocco, 11
 Mysore, 11
 Nepaul, 10
 New Leicester, 15
 Nigretti, 17
 number of, in 1698, 1741, 1800, &c., 79
 Ovis Ammon, or Argali, 9, 12
 Ovis aries, 9
 Ovis musmon, 9, 12
 Paular, 17
 Professor Archer on, 10
 Professor Owen on, 8
 Pucha sheep, 11
 Romney Marsh, 14, 26
 Saxony, 27
 smooth-haired, 11
 Southdown, 5
 Tartary, 11
 Teeswater, 15
 Transhumantes, 17
 West Indian, 12
 wild, 8, 9
 Yenu, 11
 Zeylan, 11
 Shepherd, H. W. 454
 Smiles, Dr. his account of Heilmann, 217
 Smith, A. 464, 466, 474
 Smith, J. 433, 440, 444, 447
 Smith, Messrs. 409, 444, 451, 456
 Smith, Samuel and William, 426
 Smooth haired sheep, 11
 South Australia, sheep in, 24
 Southdown, the, 5, 21

- Spain, sheep in, 29
 Spain, woollen manufactures in, 59
 Speight's patent motion, 394, 409, 448
 Spinning with distaff, 43
 Catullus on, 45
 by Alfred the Great, 44
 Square motion machine,
 Mr. Holden's first idea of, 295
 introduced to France, 302
 set aside, 302
 taken up again, 303
 first patent for, 303, 308
 improvements in, 310, 311, 320, 324
 Staples, A. 444
 Staples, F. 443
 Stead, Spence, and Wood, 436
 Stop motion, Holden, Burnley and Co.'s,
 394
 Sweden, sheep in, 27
 Switzerland, sheep in, 29
- T.
- TARTARY sheep, 11
 Tasmania, sheep in, 25
 Tavernier, Donisthorpe, and Crofts,
 379
 Tavernier, R. T. and J. T. A. 446,
 447, 450
 Taylor, Wordsworth and Co. 379, 387,
 392, 393, 475
 Teeswater sheep, 15
 Terry and Scott, 450, 462, 466, 467,
 471
 Tester, John, 172
 Thompson, Mr. George, 376
 Thompson, Mr. Matthew, 196, 204
 Thompson, Mr. M. W. 202
 Thornton and Hoyle, 463
 Tongue, W. 442-445, 450, 453, 454
 Toplis, William, 135, 424
 Townend, W. 436
 Transition period, the, 142-158
 Turkey, sheep in, 28
- U.
- UNITED STATES, sheep in, 28
 Unwin, F. 471
- V.
- VANQUELIN on the yolk, 5
 Victoria, sheep in, 24
- Vienna Exhibition, 411
 Vigourenx, J. S. 432
 Virgil on wool and sheep, 42, 45
- W.
- WADE, Mr. 369
 Walker and Stephenson, 465
 Walker, J. and F. 443
 Walker, J. C. 467, 468, 470, 471
 Walmsley, S. V. 456
 Warburton, J. 407, 430, 438, 439,
 446
 Waterhouse, Captain, 23
 Western Australia, sheep in, 25
 Western, Lord, and the merino, 21
 West Indian sheep, 12
 Westley, W. K. 438
 Whipple's invention, 411, 437, 440,
 442, 447, 448
 Whitehead, Mr. C. his sheet con-
 ductor, 392, 459
 Whitehead, Mr. H. W. 387, 392, 447,
 448, 450, 452-456, 458
 Whitehead, Mr. J. H. 392, 467,
 468, 471
 Whitehead's noil conductors, 392
 Whitehead, T. 407, 408, 435, 441
 445, 449, 450, 453, 454
 Whitley and Jowett, 444
 Whitley, T. 446
 Wild sheep, 8, 9
 William Rufus, wardrobe of, 51
 William the Conqueror, 49
 Wilson, 447
 Wood and Walker, Messrs. 183, 398
 Woolcombers' Association, 175, 179
 Wool, definition of, 2
 felting property of, 3, 83
 Professor Owen on, 2
 Youatt on, 2, 83
 W. S. B. McLaren, M.P. on, 3
 Dr. Bowman on, 4-6
 T. Burgess on, 4
 the curl of, 4
 the yolk of, 5
 analysis of, 5
 classification of, 6
 lamb's, 7
 description of fleece of, 7
 and its uses in ancient times, 34-53
 allusions to in the Bible, 35
 of Miletus, 42
 of ancient Britons, 47

- Wool—*continued.*
 industries, growth and vicissitudes of the, 54-81
 prices of in Edward III.'s time, 65
 Richard II.'s enactments concerning, 69
 trade under Henry VI. 70
 trade under Elizabeth, 71, 74
 Scottish, exportation of, to Flanders, 71
 James I. and the exportation of, 74
 early importation of, 72
 dyeing, 73
 trade under Charles I. 74
 Sir Josiah Child on, 77
 and its manufacturing processes, 82-104
 sorting, 84
 washing, 368, 413
 supply committee, 413
 Woolcombing establishment, description of a, 91-104
 machine, Cartwright's, 113
 machine, petitions against the, 114
 in France, 301
- Woolcombing—*continued.*
 and the worsted manufacture, 404
 inventions, list of, 421
 Worstead, Flemish artisans at, 50
 Worsted Committee, 165
 Worsted manufacture, early mention of the, 51
 Worsted manufacture under Edward II. 51
 Worsted processes, 87-104
 Wortley, M.P. Mr. 168
 Wright and Hawksley, 137, 423
- Y.
- YENU sheep, 11
 Yolk, the, 5, 6
 Youatt on wool; 2
 on sheep, 78
- Z.
- ZEYLAN sheep, 11
 Ziegler, J. J. 431, 440

THE END.

